

# 487

## ADJUSTMENT MANUAL

This Adjustment Manual is valid for machines  
from the following serial numbers onwards:

# 2 756 862 →

The reprinting, copying or translation of PFAFF Service Manuals, whether in whole or in part, is only permitted with our previous authorization and with written reference to the source.

**PFAFF Industriesysteme  
und Maschinen AG**

Hans-Geiger-Str. 12 - IG Nord  
D-67661 Kaiserslautern

	Contents .....	Page
1	Adjustment.....	4
1.01	Notes on adjustment .....	4
1.02	Tools, gauges and other accessories for adjusting .....	4
1.03	Abbreviations .....	4
1.04	Explanation of the symbols.....	4
1.05	Checking and adjusting aid .....	5
1.06	Adjusting the basic machine .....	6
1.06.01	Balancing weight.....	6
1.06.02	Needle in needle-hole centre.....	7
1.06.03	Neutral position of drop feed ( Adjustment with the gearcase closed.....	8
1.06.04	Adjustment with the gearcase opened.....	9
1.06.05	Actuating lever under the reverse-feed control.....	10
1.06.06	Feeding motion of drop feed.....	11
1.06.07	Lifting motion of drop feed .....	12
1.06.08	Height of drop feed dog.....	13
1.06.09	Clearance between presser foot and needle plate .....	14
1.06.10	Top feed actuating link .....	15
1.06.11	Neutral position of top feed .....	16
1.06.12	Feeding motion of the top feed dog .....	18
1.06.13	Vibrating presser clearance.....	19
1.06.14	Top feed lifting motion .....	20
1.06.15	Position of lifting presser .....	21
1.06.16	Synchronizing the top feed .....	22
1.06.17	Stitch length alignment .....	23
1.06.18	Eccentric hook shaft bearing and hook-to-needle clearance.....	24
1.06.19	Final adjustment of needle rise, needle height, and bobbin case position finger.....	25
1.06.20	Bobbin case opener height .....	26
1.06.21	Adjustment of the bobbin opener.....	27
1.06.22	Bobbin case opener motion .....	28
1.06.23	Needle thread tension release.....	29
1.06.24	Thread check spring and thread regulator.....	30
1.06.25	Bobbin winder.....	31
1.06.26	Knee lever resting position .....	32
1.06.27	Knee lever play.....	33
1.06.28	Knee lever stroke limitation .....	34
1.06.29	Position of vibrating presser in relation to lifting presser .....	35
1.06.30	Pressure of the vibrating- and lifting pressers.....	36
1.06.31	Stitch length limitation .....	37
1.07	Parameter settings (only on machines with EcoDrive and control unit P40 ED).....	38
1.07.01	Parameter list.....	38
2	Circuit diagrams .....	39

## 1 Adjustment



Please observe all notes from Chapter **1 Safety** of the instruction manual! In particular care must be taken to see that all protective devices are refitted properly after adjustment, see Chapter **1.06 Danger warnings of the instruction manual!**



If not otherwise stated, the machine must be disconnected from the electrical power supply.  
Danger of injury due to unintentional starting of the machine!



On the **PFAFF 487** do not use a screw clamp on the needle bar!  
The special coating of the needle bar could be damaged.

### 1.01 Notes on adjustment

All following adjustments are based on a fully assembled machine and may only be carried out by expert staff trained for this purpose. Machine covers, which have to be removed and replaced to carry out checks and adjustments, are not mentioned in the text.

The order of the following chapters corresponds to the most logical work sequence for machines which have to be completely adjusted. If only specific individual work steps are carried out, both the preceding and following chapters must be observed.

Screws, nuts indicated in brackets ( ) are fastenings for machine parts, which must be loosened before adjustment and tightened again afterwards.

### 1.02 Tools, gauges and other accessories for adjusting

- Set of screwdrivers with blade widths from 2 to 10 mm
- Set of open-ended spanners, 7 to 14 mm across-flats
- Set of allen keys, 1.5 to 6 mm
- Metal rule, part No. 08-880 218-00
- Adjustment pin (5 mm dia.), part No. 13-030 341-05
- Adjustment gauge, part. No. 61-111 639-49
- Adjustment link, part No. 91-069 375-15
- Adjustment foot, part No. 61-111 639-20

### 1.03 Abbreviations

TDC = top dead center

BDC = bottom dead center

### 1.04 Explanation of the symbols

In this adjustment manual, symbols emphasize operations to be carried out or important information. The symbols used have the following meaning:



Note, information

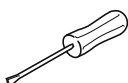

Service, repair, adjustment, maintenance  
(work to be carried out by qualified staff only)

## 1.05 Checking and adjusting aid



By blocking holes 1 to 6 with a pin it is possible to accurately fix the required needle bar positions.

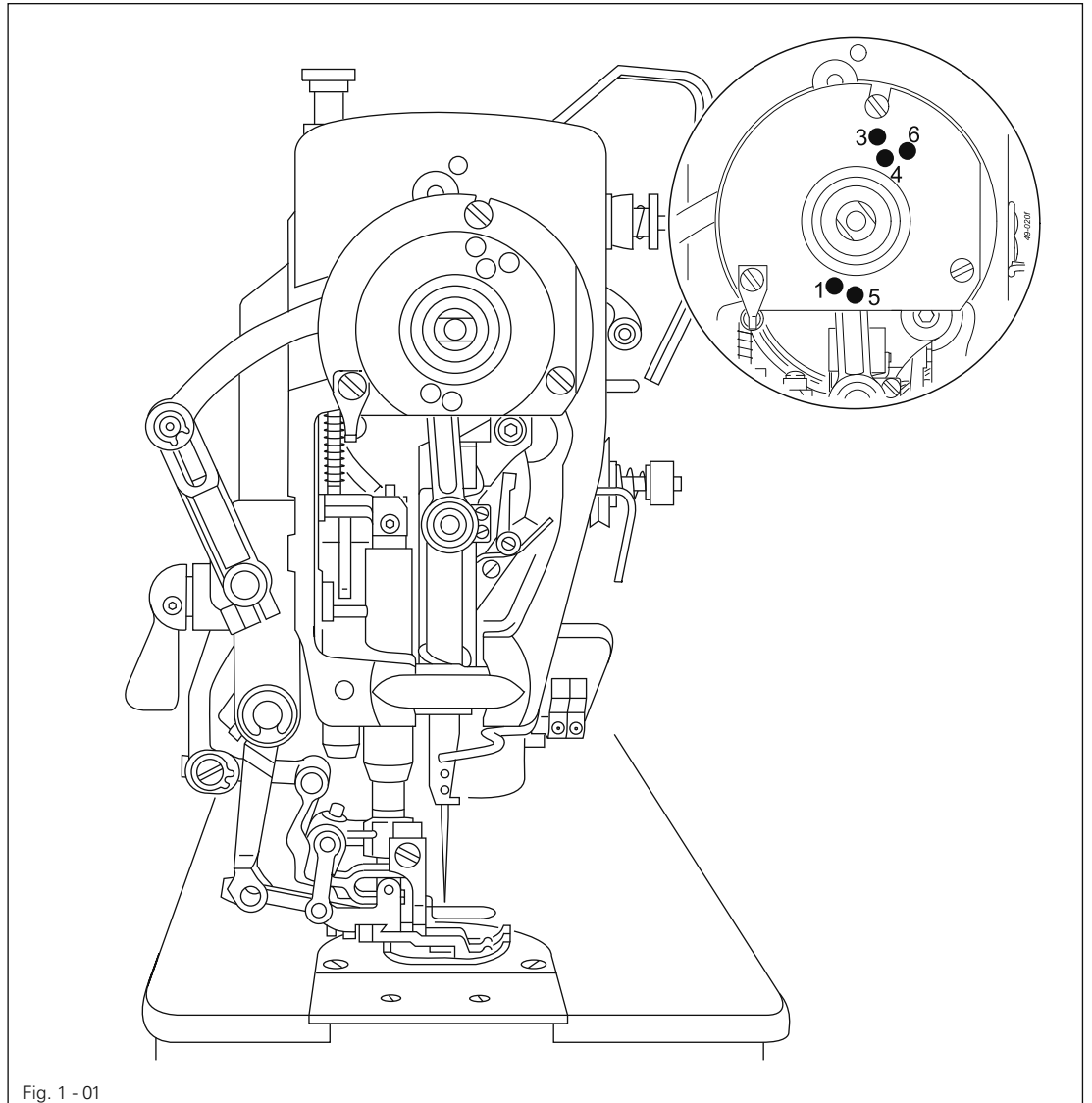
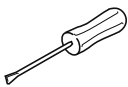

Fig. 1 - 01



- Turn the balance wheel until the needle bar is roughly in the required position.
- Insert the blocking pin in the required hole and press against it.
- Turn the balance wheel slightly back and forth so that the pin enters the cutout in the bearing plate behind and thus blocks the machine.

- Hole 1 = 0.6 mm past top dead centre of the needle bar (0.6 past t.d.c.)  
 Hole 3 = 0.6 mm past bottom dead centre of the needle bar (0.6 past b.d.c.)  
 Hole 4 = 1.8 mm past bottom dead centre of the needle bar (needle rise position)  
 Hole 5 = top dead centre of the needle bar (t.d.c.)  
 Hole 6 = 4 mm past bottom dead centre of the needle bar (4 past b.d.c.)

# Adjustment

## 1.06 Adjusting the basic machine

### 1.06.01 Balancing weight

#### Requirement

With the needle bar at b.d.c. the underside of the needle bar must be at a distance of approx. **16.5 mm** from the needle plate.

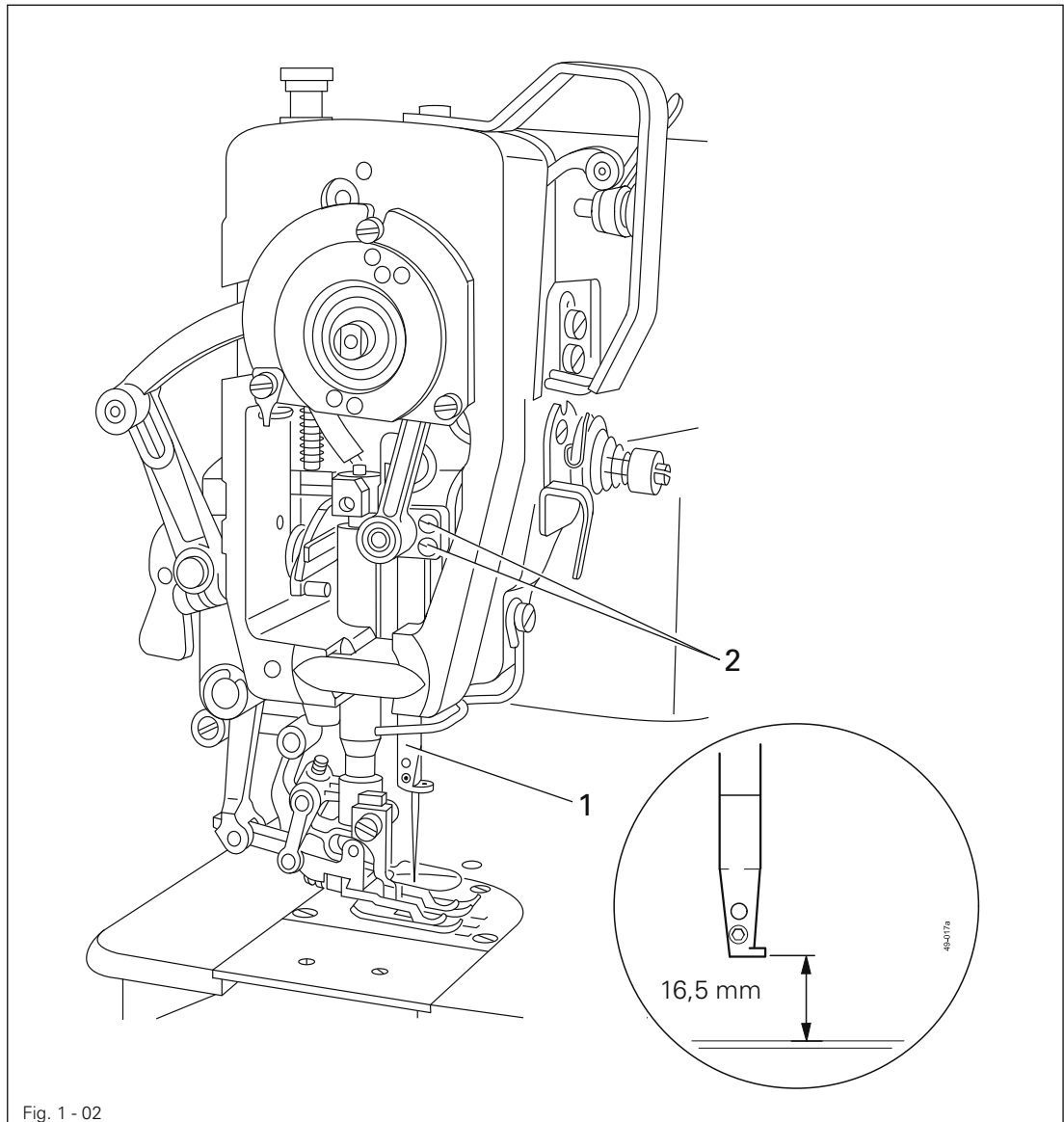
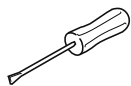

Fig. 1 - 02



- Re-position needle bar 1 (screws 2) according to Requirement.

## 1.06.02 Needle in needle-hole centre

**Requirement**

The needle must enter exactly in the centre of the needle hole.

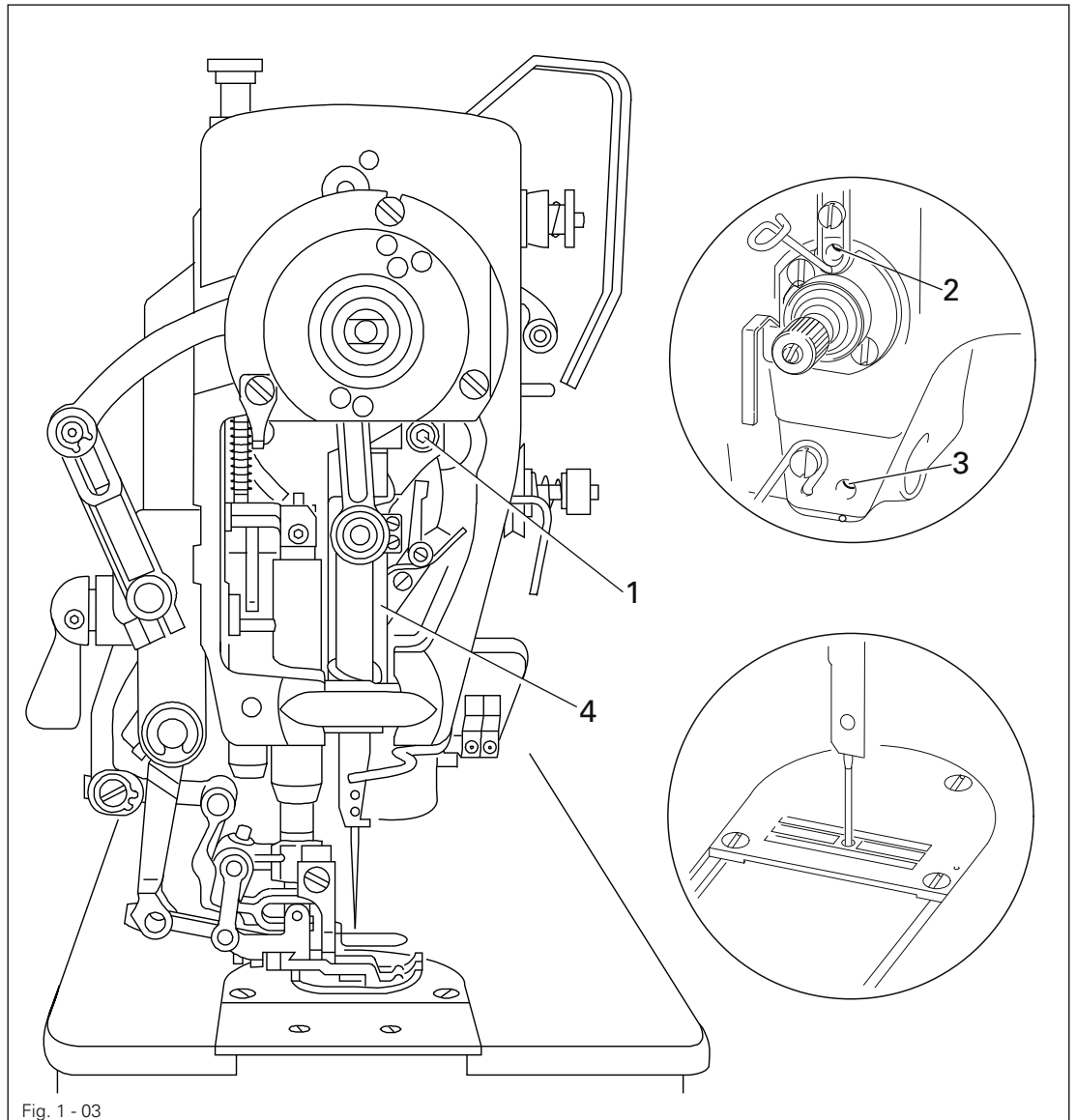
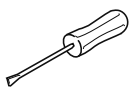

Fig. 1 - 03



- Set the needle immediately above the needle hole.
- Loosen screws 1, 2 and 3.
- Reposition needle bar frame 4 according to the **Requirement** both crosswise and lengthwise of the feeding direction.
- Tighten screw 3 firmly and screw 2 just a little.
- Turn screw 1 to take up the guide pin behind it against the eye of the needle bar frame and tighten it.
- Take out the needle.
- Loosen screw 2, turn the balance wheel a few turns (to remove any binding) and tighten screw 2 firmly.

# Adjustment

## 1.06.03 Neutral position of drop feed ( Adjustment with the gearcase closed)

### Requirement

At stitch length setting "0" the drop feed must not make any feeding movement when the balance wheel is turned.

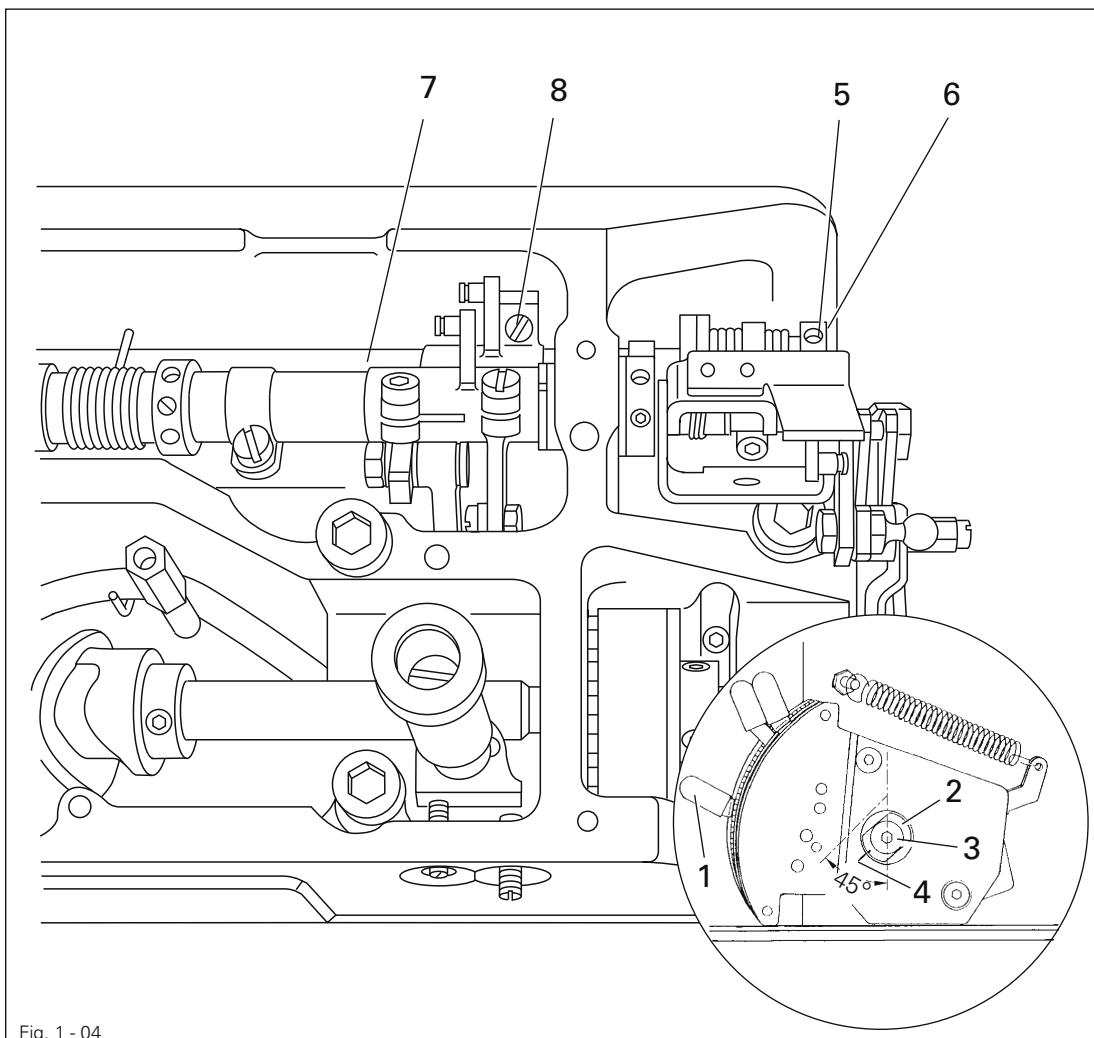
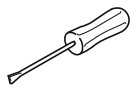

Fig. 1 - 04



- Set feed regulator lever **1** in its lowest position.
- Turn bush **2** (screw **3**) so that mark **4** is facing downwards and the edge of the milled surface is at an angle of approx. **45°** to the front side of the machine.
- (For the final adjustment, see Chapter 1.0.06.16 "Top feed synchronization".)
- Insert a suitable pin or allen key in hole **5** of tensioning ring **6** and hold shaft **7** with it firmly.
- Turn shaft **7** (screw **8**) according to **Requirement**.



## 1.06.04 Adjustment with the gearcase opened

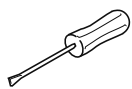
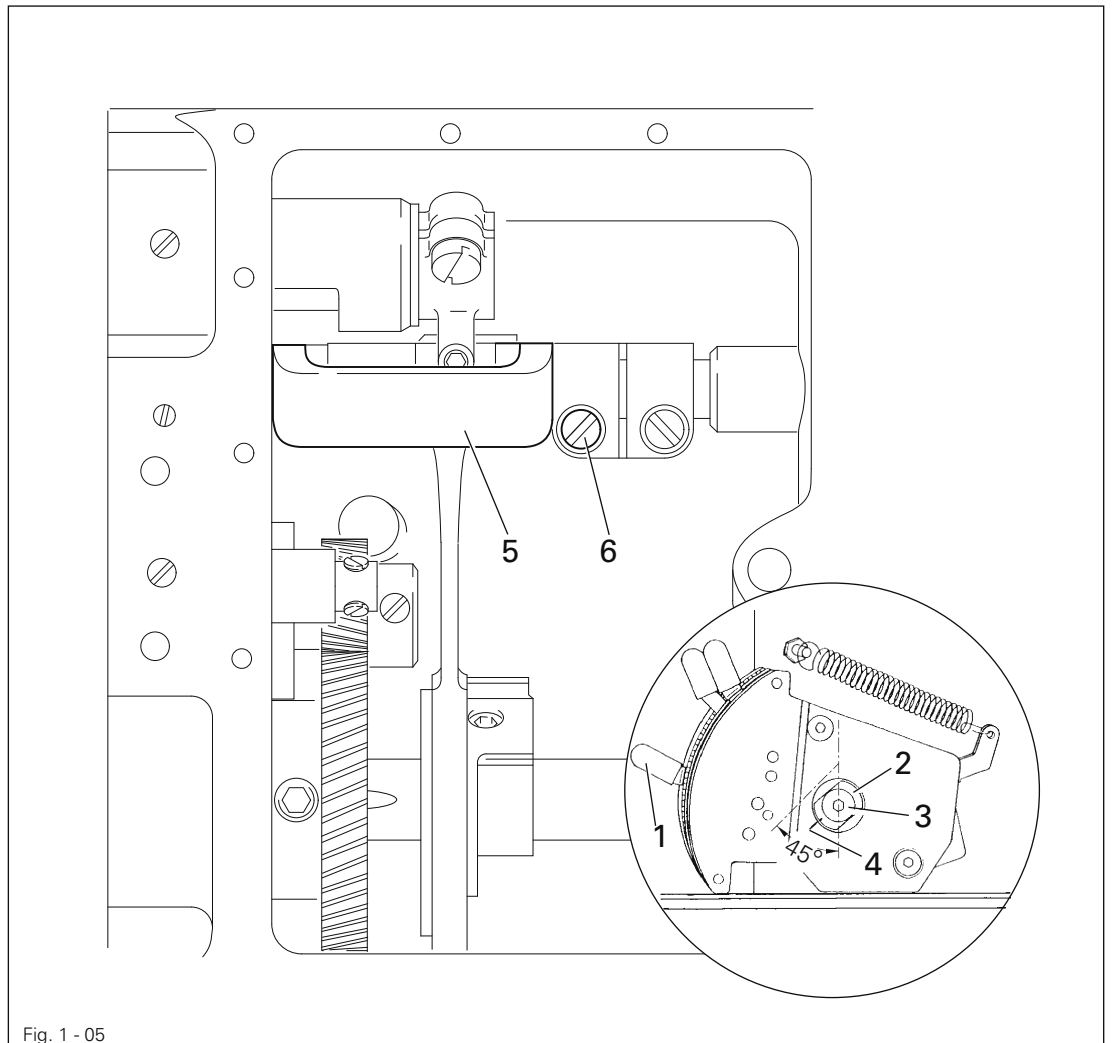

- Set feed regulator lever 1 in its lowest position.
- Turn bush 2 (screw 3) so that mark 4 is facing downwards and the edge of the milled surface is at an angle of approx. 45° to the front side of the machine.  
(For the final adjustment, see Chapter 1.06.16 "Top feed synchronization".)
- Turn crank 5 (screw 6) according to Requirement.

# Adjustment

## 1.06.05 Actuating lever under the reverse-feed control

### Requirement

At the longest stitch length setting, reverse-feed control lever 3 must have a slight play (approx. 0.3 mm) when pressed lightly.

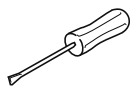
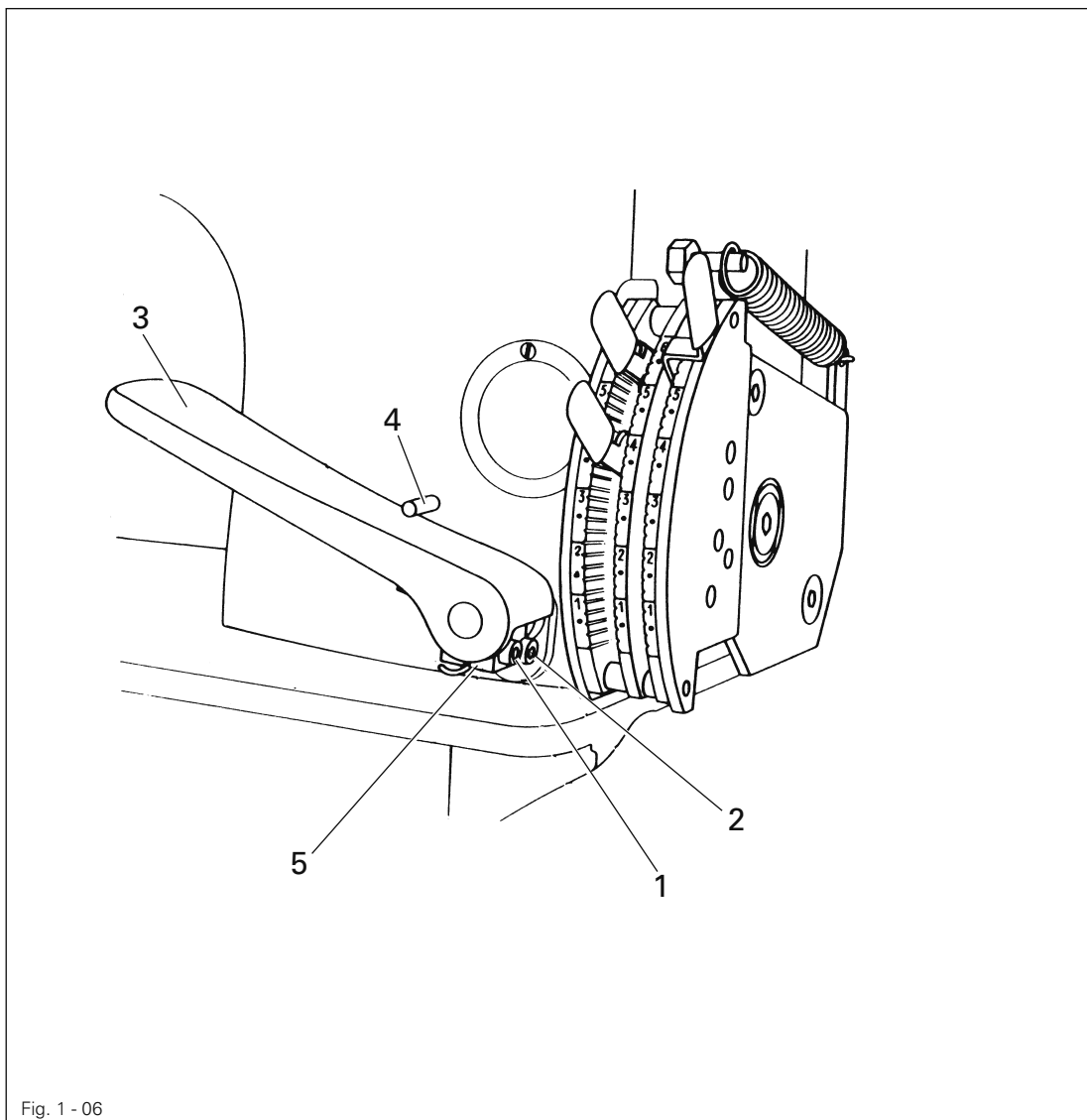

- Loosen screws 1 and 2.
- Make sure that reverse-feed control lever 3 is resting on stop 4, move actuating lever 5 lightly against the reverse-feed control and tighten screw 1 again.



Leave screw 2 loose until the top-feed neutral position is adjusted (Chapter 1.06.11).

## 1.06.06 Feeding motion of drop feed

**Requirement**

At the longest stitch length setting and with the needle bar in position 0.6 past t.d.c. (blocking hole 1) the feed dog must not move when the reverse-feed control is operated.

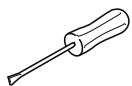
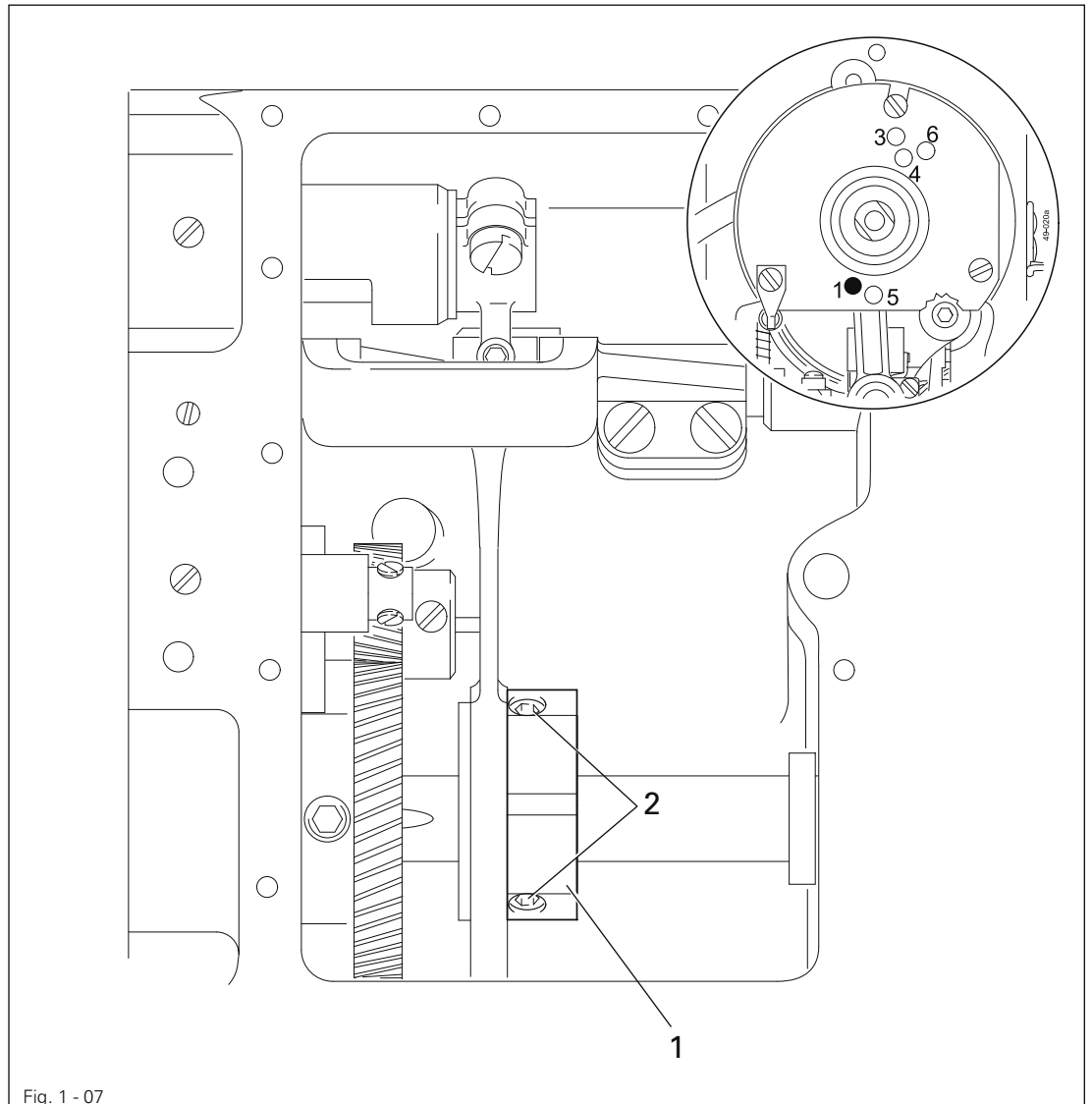

- Turn feed eccentric 1 (screws 2) according to **Requirement**. Make sure that the cutout in the feed eccentric is visible.

# Adjustment

## 1.06.07 Lifting motion of drop feed

### Requirement

At stitch length setting "0" and with the needle bar in position **0.6 past t.d.c.** (blocking hole 1) the feed dog must be at t.d.c.

The cutout in lifting eccentric **1** must face roughly vertically downwards.

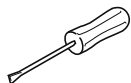
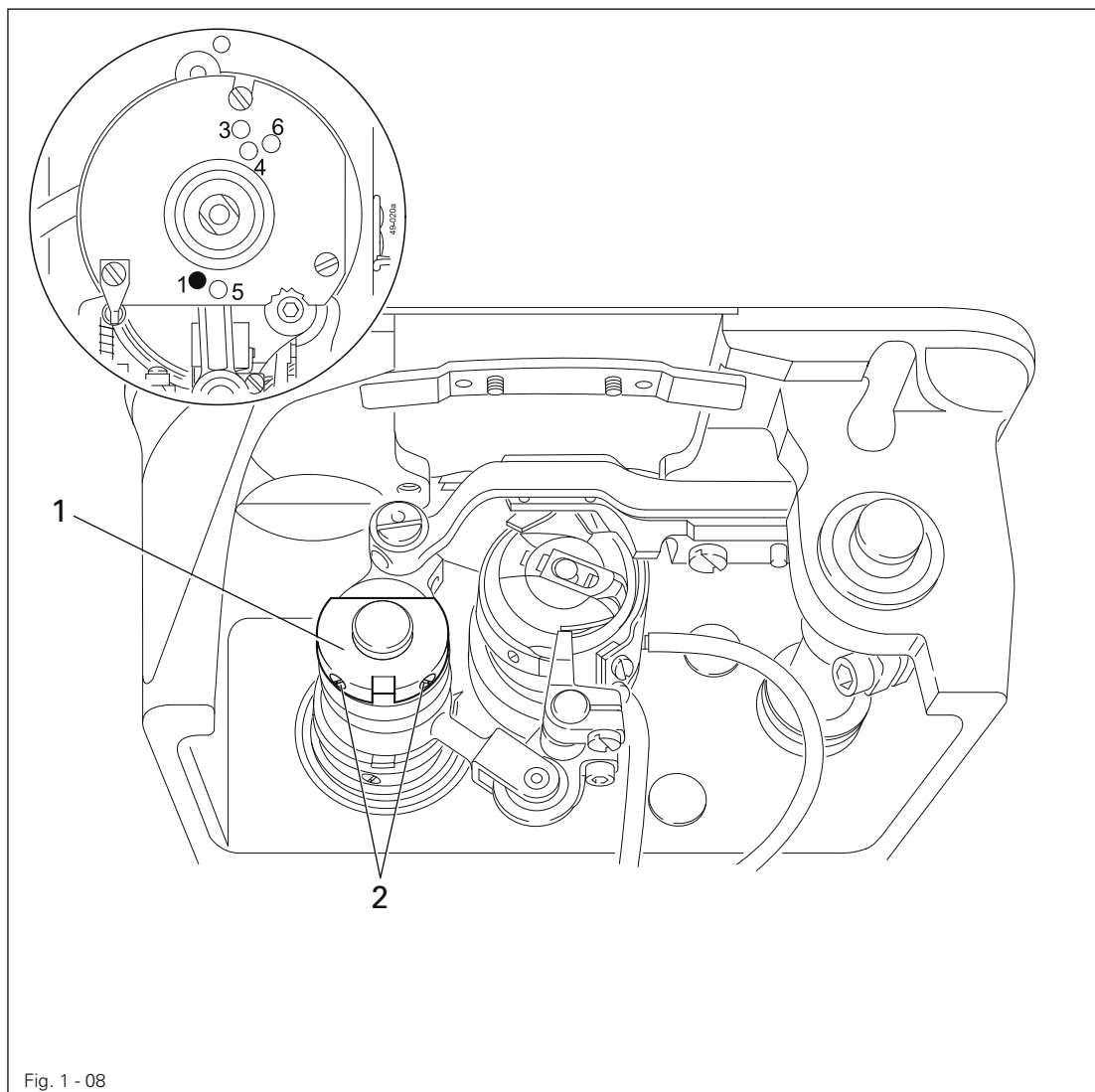

- Turn lifting eccentric **1** (screws **2**) according to **Requirement**.



Make sure that there is slight play between lifting eccentric **1** and the crank lever behind it.

## 1.06.08 Height of drop feed dog

### Requirement

At stitch length setting "0" and with the needle bar in position **0.6 mm past t.d.c.** (blocking hole 1) the feed dog must:

1. be centred in the feed slots of the needle plate both crosswise and lengthwise,
2. be at top dead centre and resting against the adjustment gauge throughout its length.

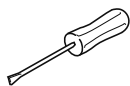
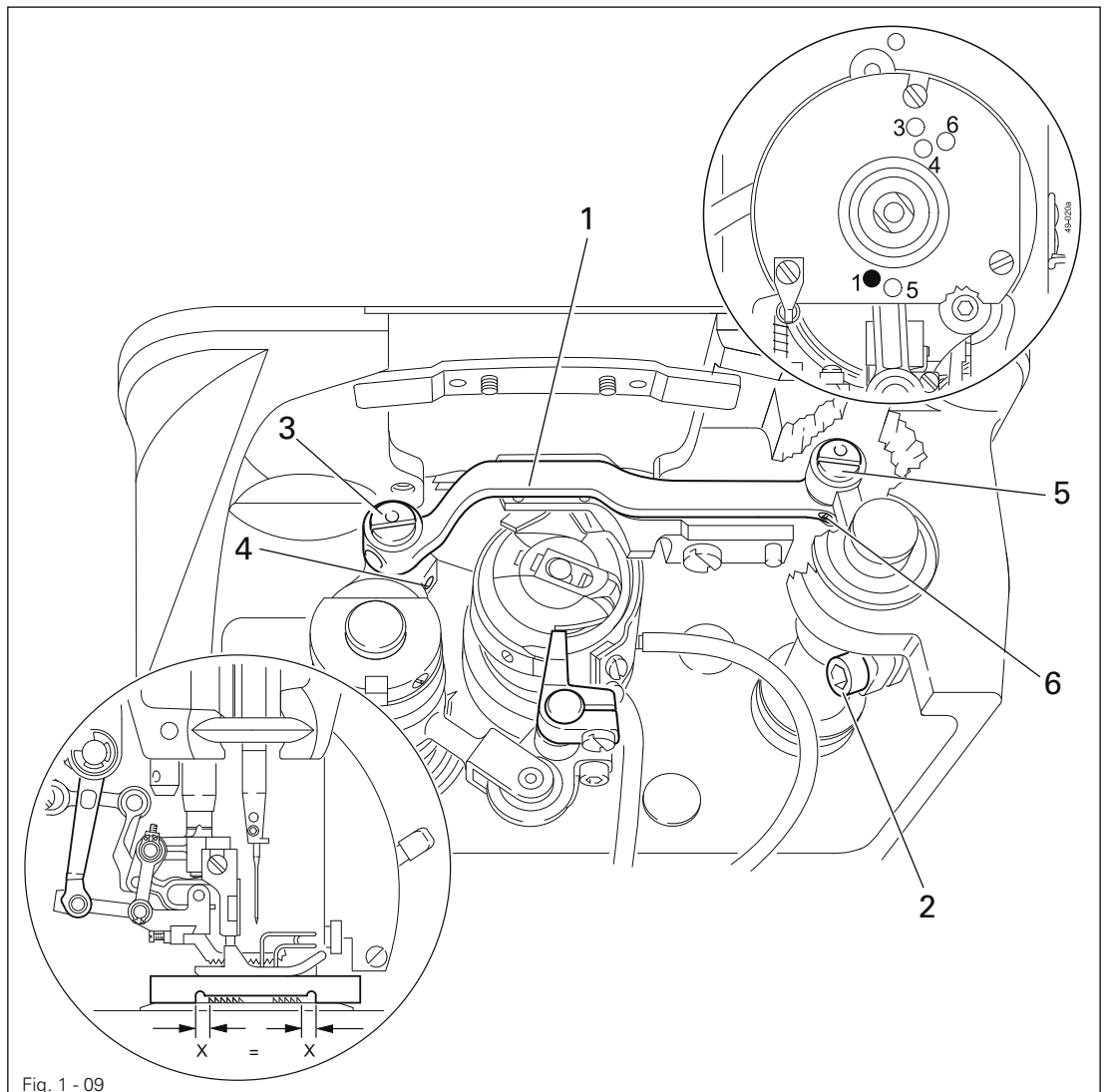

- Reposition feed bar 1 (screws 2) according to **Requirement 1**.
- Lower presser foot onto gauge.
- Turn eccentric 3 (screws 4) and eccentric 5 (screws 6) according to **Requirement 2**.

### Requirement

When lifting lever 1 is raised there must be a clearance of 5 mm between the presser foot and the needle plate.

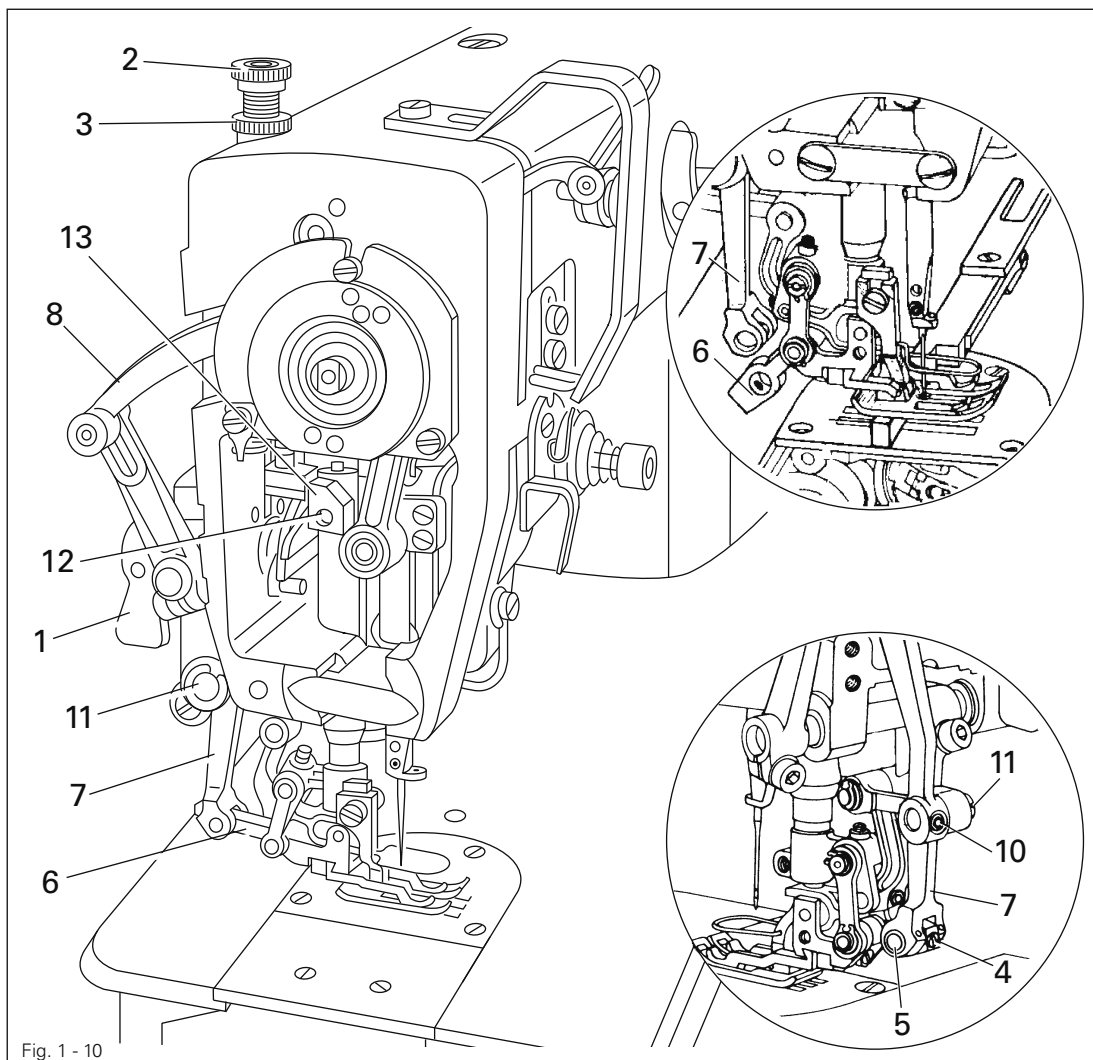
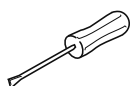

Fig. 1 - 10



- Lower presser foot onto needle plate using lifting lever 1.
- Reduce pressure on the presser bar by unscrewing regulating screw 2 (knurled nut 3).
- Loosen screw 4, push pin 5 out and swing link 6 out of the fork of lever 7.
- Set lever 8 at its outermost position by turning the balance wheel.
- Place the feed-dog adjustment gauge, cutout facing downwards, under the presser foot.
- Loosen screw 10 and push pin 11 out.
- Loosen screw 12.
- Position the presser foot crosswise so that its edge is parallel with the needle plate cutout
- Move lifting piece 13 fully down and tighten screw 12.



Leave screws 4 and 10 loose for the next adjustment.

## 1.06.10 Top feed actuating link

**Requirement**

1. All moving parts of the top feed must move freely but without any play.
2. The vibrating presser must not contact the lifting presser.

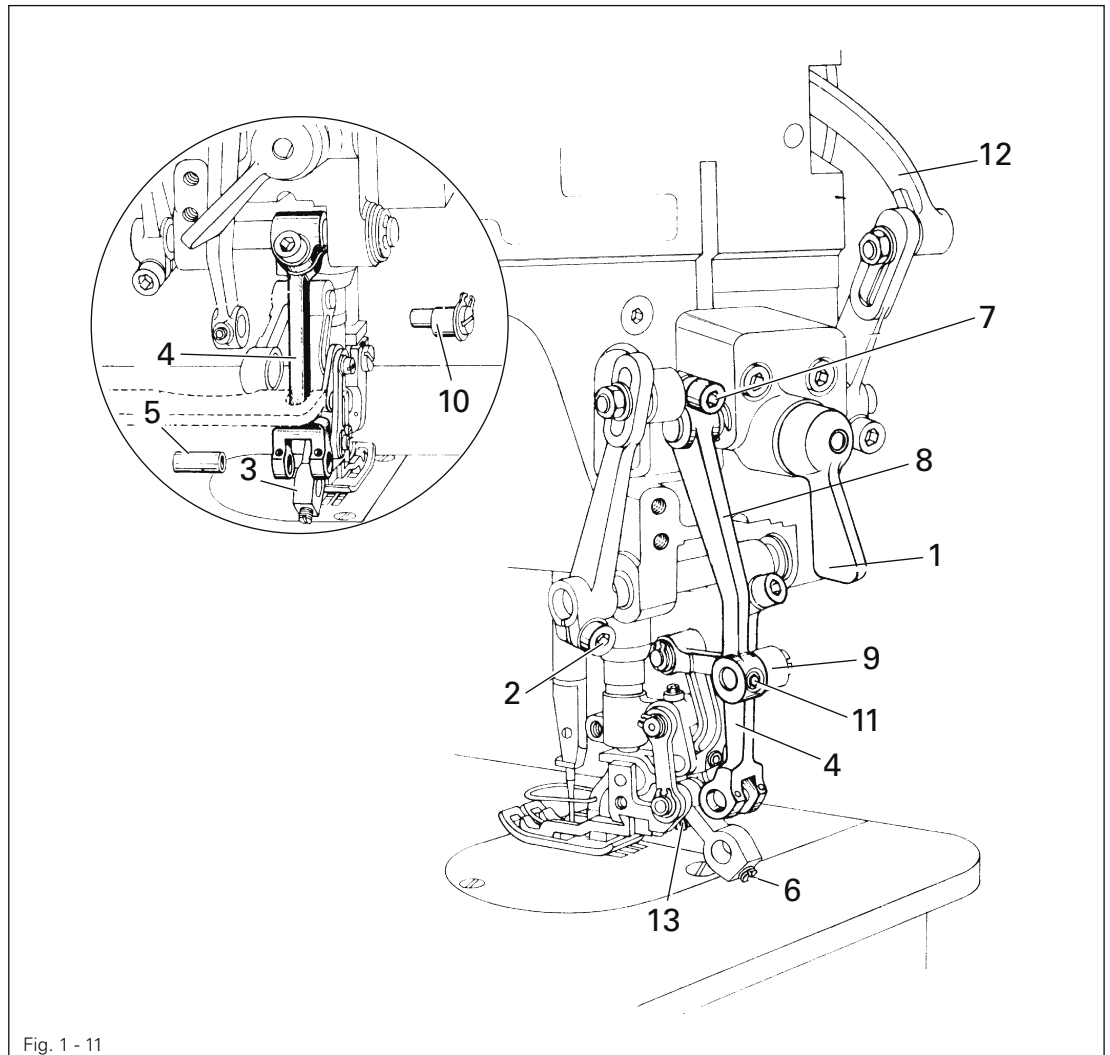
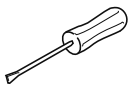

Fig. 1 - 11



- Lower the presser foot using lifting lever 1.
- Loosen screw 2.
- Swing link 3 into the fork of lever 4, insert pin 5 and tighten screw 6 (check for free movement and set lever 4 if necessary).
- Set stitch length at "0".
- Position vibrating presser at centre of lifting presser cutout and tighten screw 2.
- Loosen screw 7.
- Align the hole in lever 8 with the elongated hole of lever 9, without any lateral play, if necessary re-position or set lever 8.
- Insert pin 10 with its eccentric lobe facing downwards into the holes of levers 9 and 8 and tighten screw 11.
- Move lever 12 to its outermost position.
- Push lever 8 in feeding direction until you feel it move into contact, and tighten screw 7.
- Position the vibrating presser crosswise so that it does not touch the lifting presser (screw 13).

# Adjustment

## 1.06.11 Neutral position of top feed

### Requirement

With the stitch length and top feed set at "0" and with adjustment link 9 fitted, drive lever 22 must not make any movement when the balance wheel is turned.

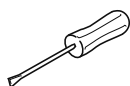
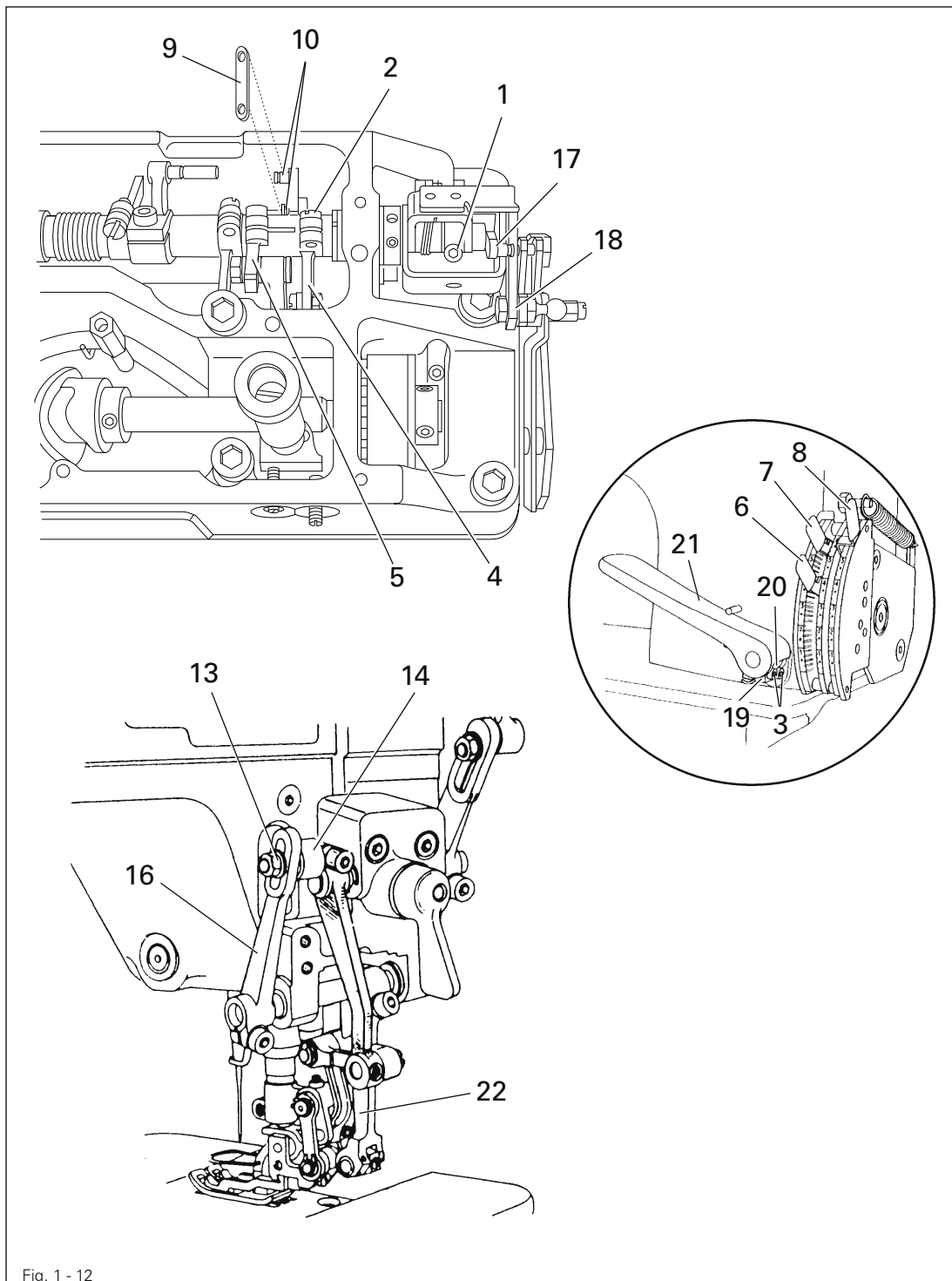

- Raise the presser foot.
- Loosen screws 1, 2 and 3.
- Set crank 4 parallel with crank 5 and tighten screw 2.



- Set feed regulator levers **6**, **7** and **8** at "0".
- Fit adjustment link **9** onto pins **10**.
- Rotate the balance wheel and turn crank **11** (screw **12**) so that the vibrating presser no longer moves.
- Loosen nut **1**.
- Move linkage **14** up and down several times, and while doing so adjust lever **16** (screw **15**) so that the vibrating presser no longer moves.
- Set linkage **14** at the top end of the elongated hole and tighten nut **1**.
- Set feed regulator levers **6**, **7** and **8** at "3".
- Move crank **17** axially and radially against crank **18** and tighten screw **1**.
- Remove adjustment link **9**.
- Push feed regulator levers **6**, **7** and **8** fully to the top.
- Set a clearance of **0.5 mm** between reverse-feed lever **21** and actuating levers **19** and **20** and tighten screw **3**.

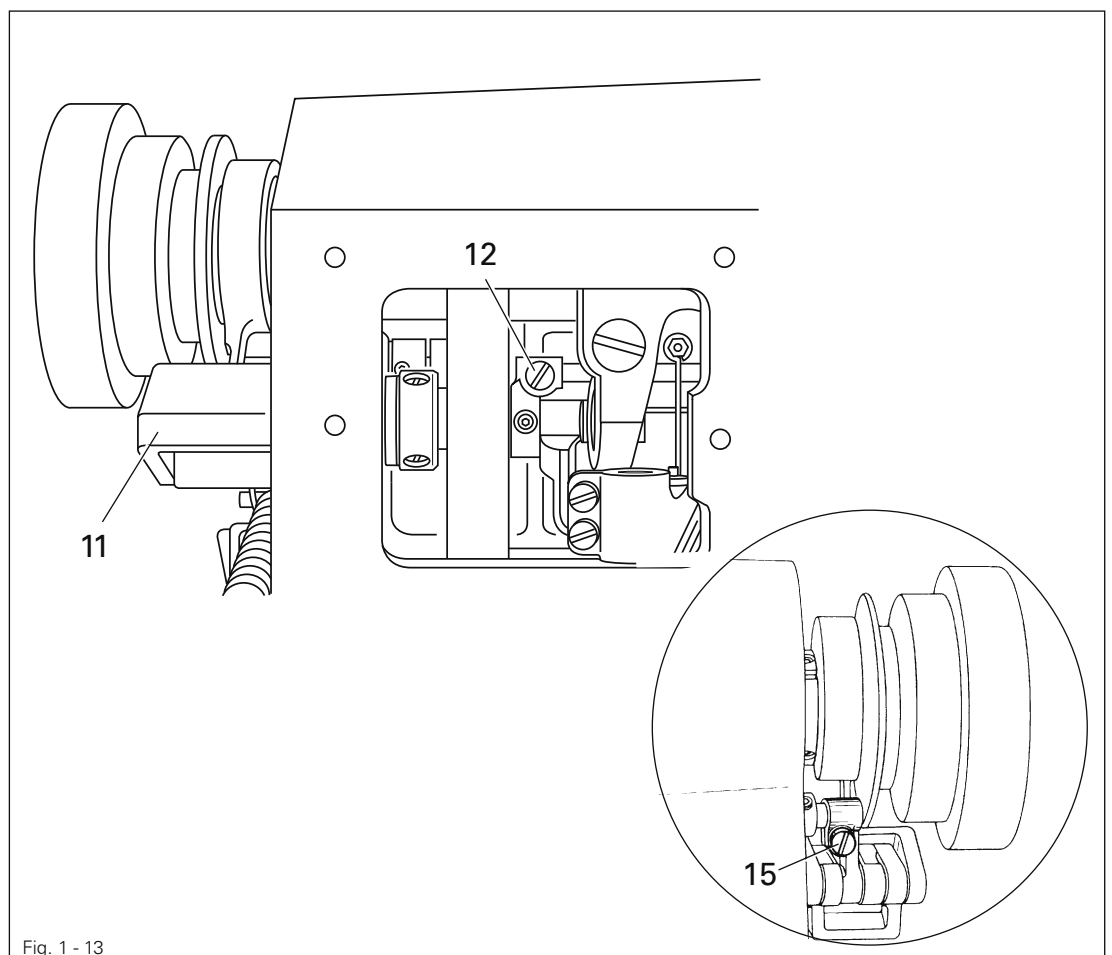
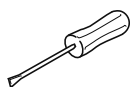
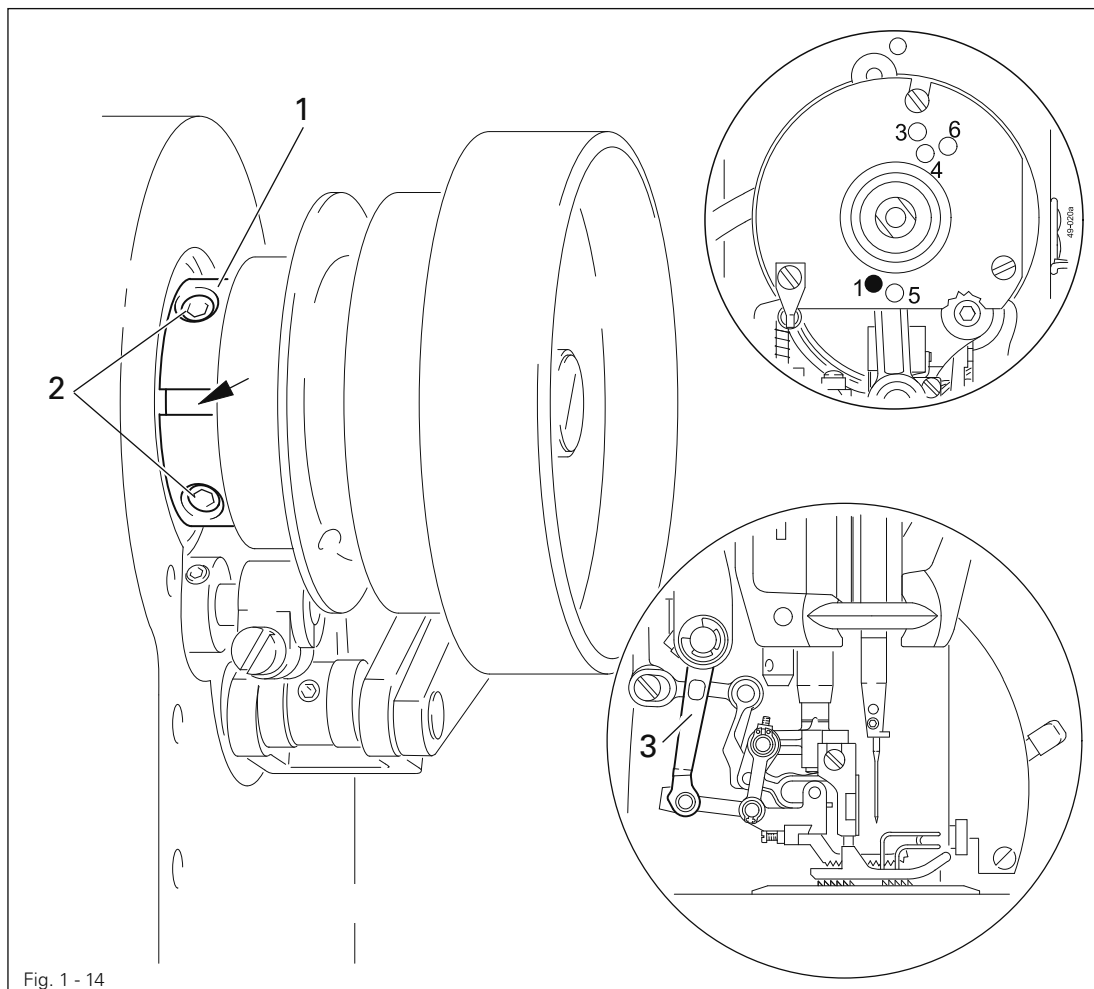

Fig. 1 - 13

## 1.06.12 Feeding motion of the top feed dog

### Requirement

When the needle bar is positioned **0.6 mm past t.d.c** (adjustment hole 1) and the maximum stitch length is set, lever **3** should not move when the feed reverse key is operated.



- While continuously operating the feed reverse key, adjust eccentric **1** (screws **2**) so that the slot is pointing towards the operator and lever **3** does not move.

## 1.06.13 Vibrating presser clearance

### Requirement

When the presser foot is touching the needle plate and the vibrating presser is at top dead centre, depending on the top feed version, with the stitch length set at "0" there should be the following clearance between the needle plate and the vibrating presser:

**1.3 mm** when the vibrating presser is operating behind the needle

**3.2 mm** when the vibrating presser is operating in front of the needle



When sewing thin materials, on machines with the vibrating presser operating in front of the needle, the top feed stroke can be limited to **2.0 mm** by pushing bolt **9** (nut **10**) up as far as possible.

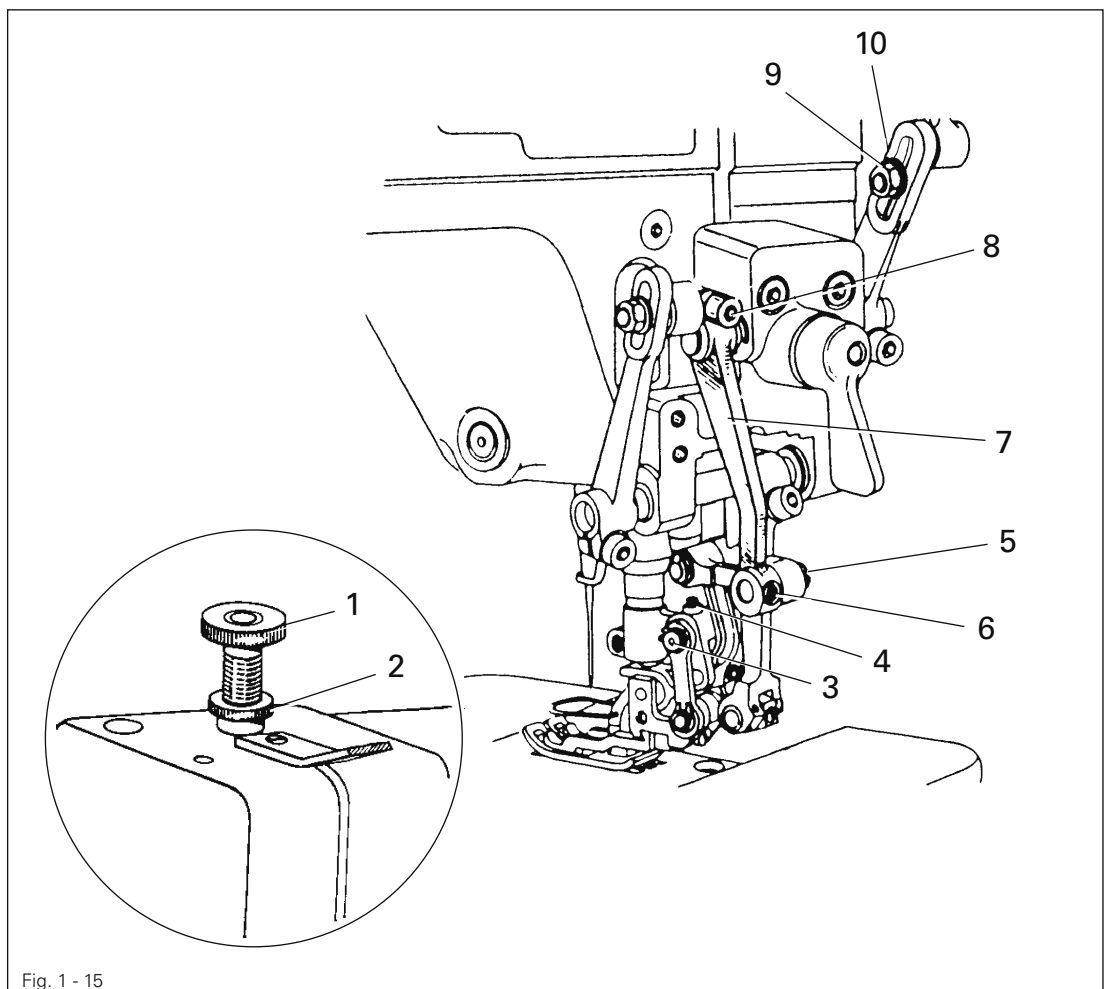
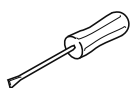

Fig. 1 - 15



- Increase the presser foot pressure somewhat on screw **1** (nut **2**).
- Lower the presser foot onto the needle plate.
- Position the eccentricity of pin **3** (screw **4**) facing the needle bar.
- Position the eccentricity of pin **4** (screw **6**) facing downwards.
- Turn the balance wheel until link **7** is in its far rear position.
- Push lever **7** (screw **8**) down and insert the corresponding feeler gauge (see **Requirement**) between the vibrating presser and the needle plate.
- If fine adjustment is required, turn eccentric pin **5** (screw **6**) accordingly.

# Adjustment

## 1.06.14 Top feed lifting motion

### Requirement

With the stitch length set at "2" the lifting presser must rest on the bottom feed dog (see arrow) when the rising bottom feed dog has reached the upper surface of the needle plate.

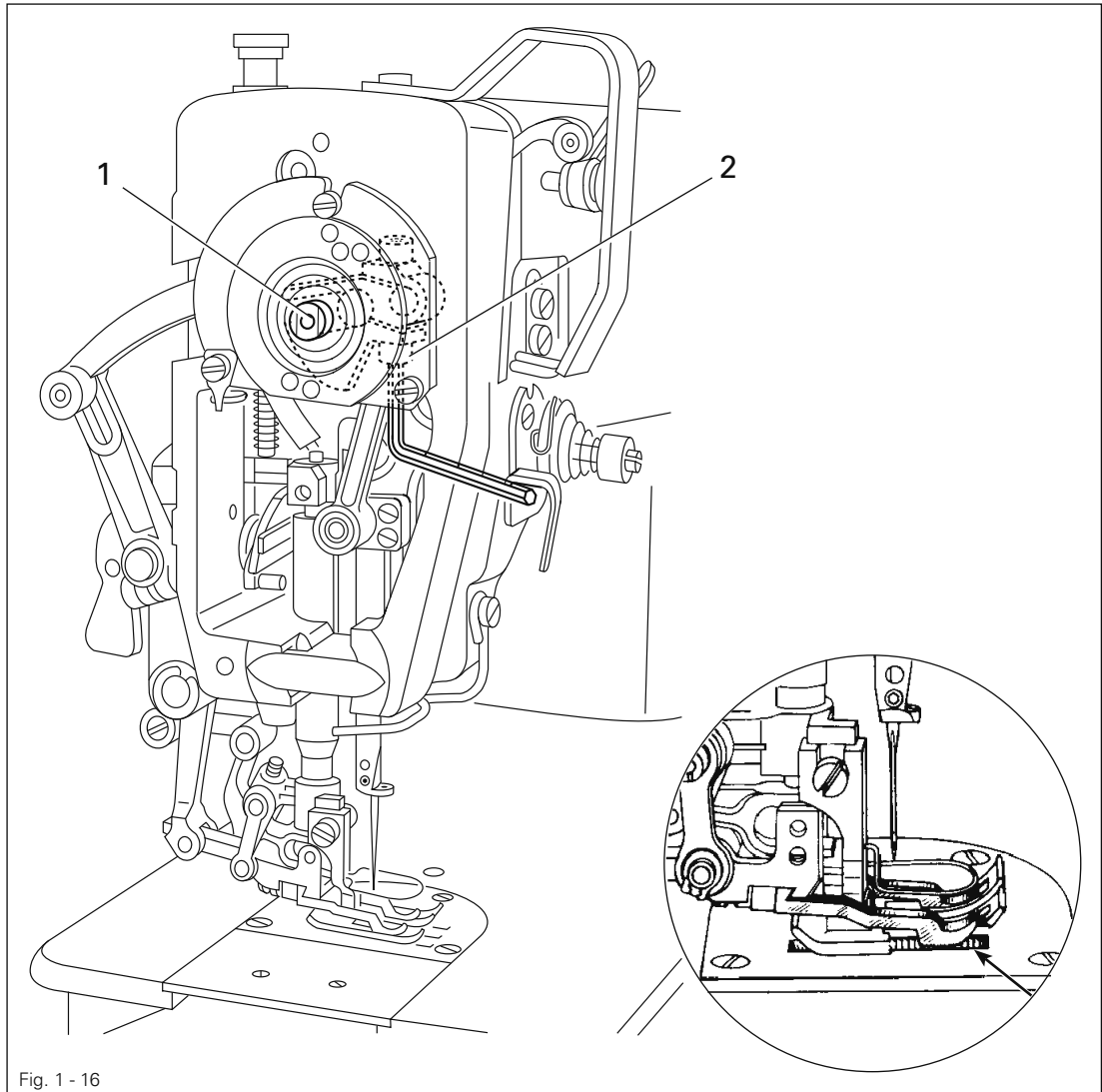
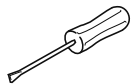

Fig. 1 - 16



- Turn eccentric pin 1 (screw 2) according to Requirement.

## 1.06.15 Position of lifting presser

### Requirement

When the bottom feed dog is at t.d.c. the lifting presser must be parallel with the drop feed dog.

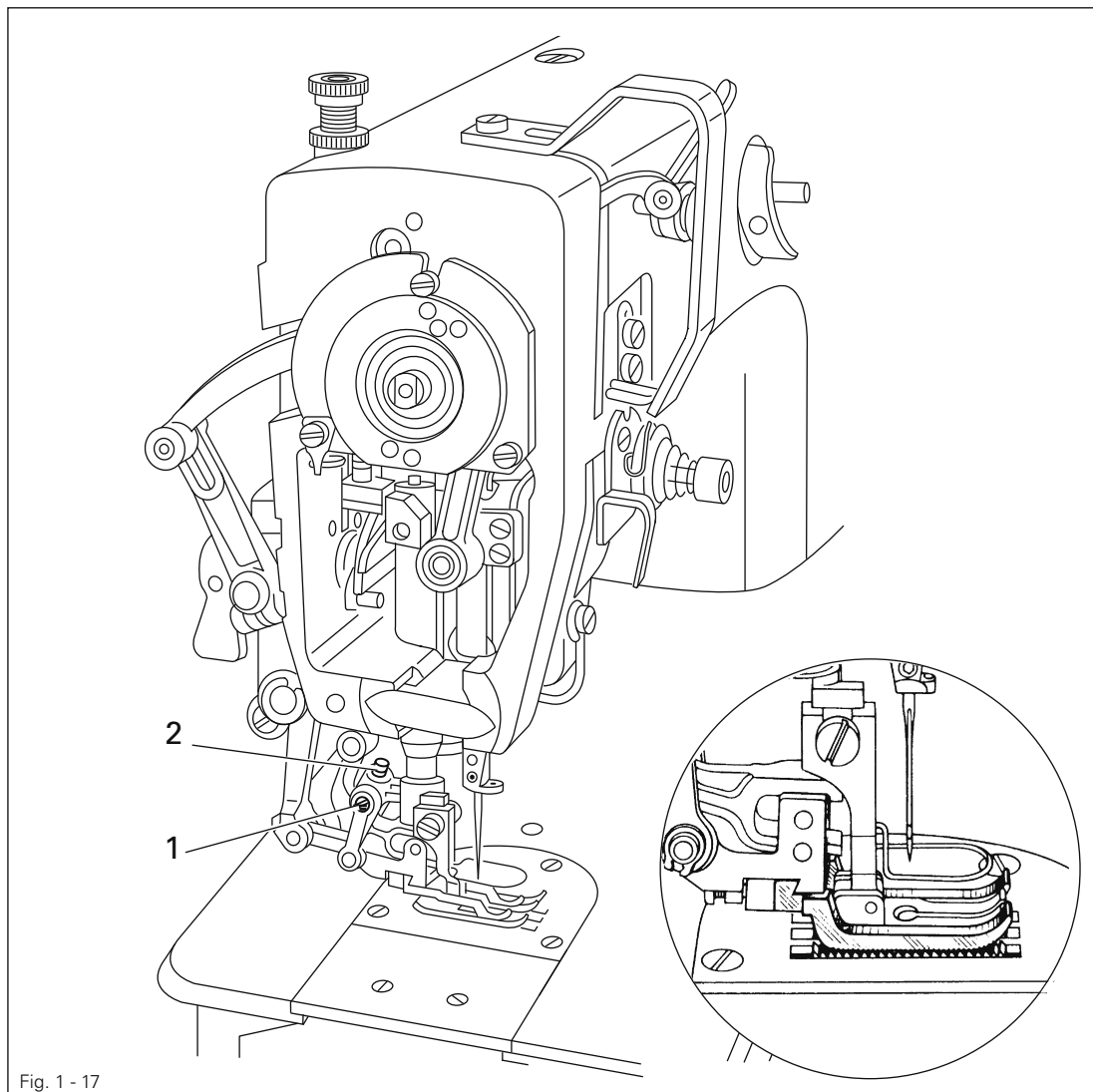
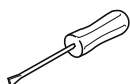

Fig. 1 - 17



- Turn eccentric pin 1 (screw 2) according to Requirement.

# Adjustment

## 1.06.16 Synchronizing the top feed

### Requirement

When the feed regulator levers for stitch length and top-feed stroke are set at "3", both top feed and bottom feed must move at the same stroke when the balance wheel is turned.

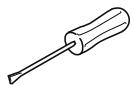
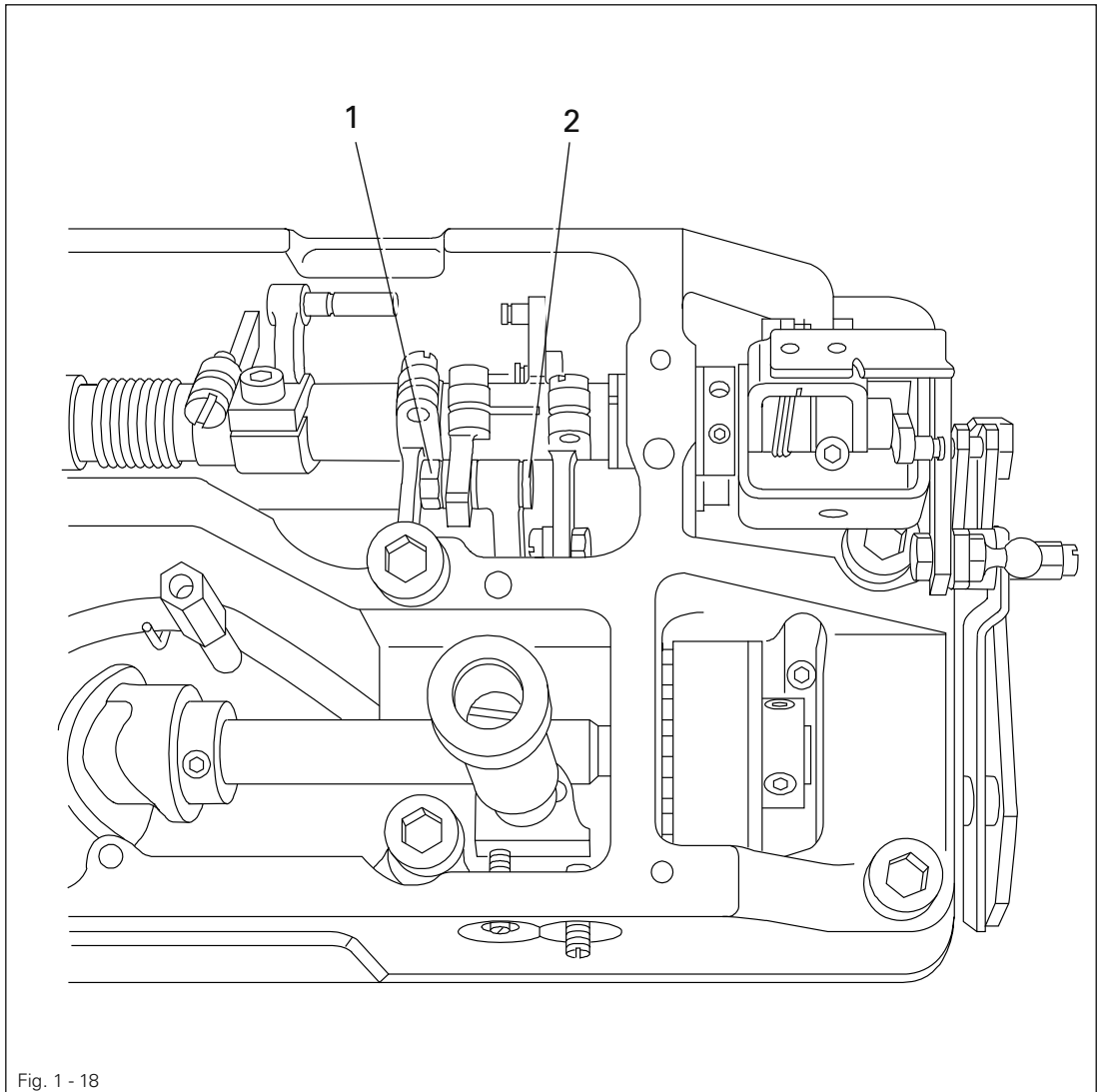

- Press the reverse-feed lever and loosen nut **1** accessible behind it.
- Position screw **2** in the slot according to **Requirement** and tighten nut **1**.

## 1.06.17 Stitch length alignment

### Requirement

When the stitch length is set at "3" the feed stroke must be the same in forwards and reverse feeding

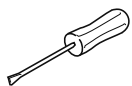
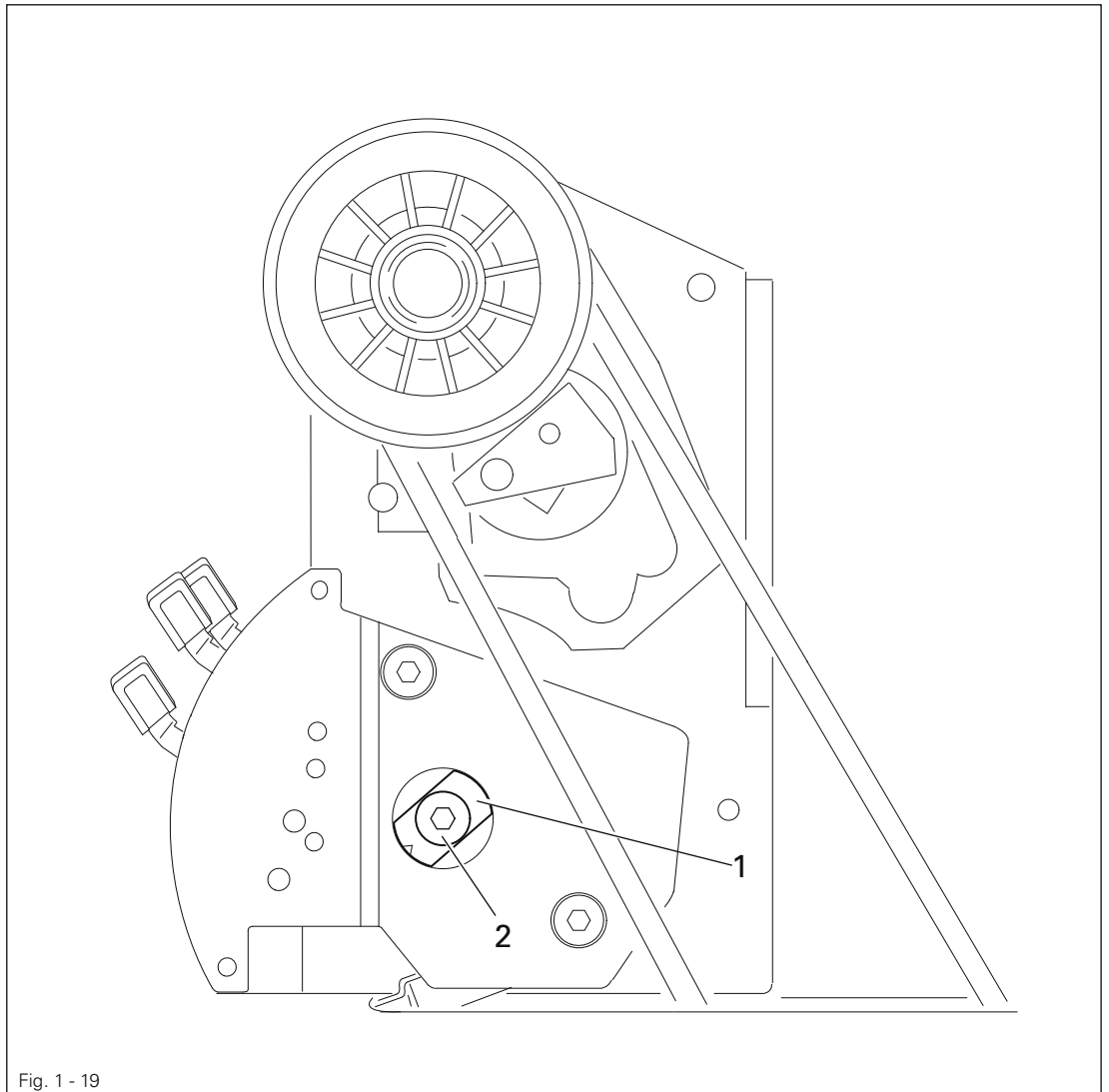

- Turn bush 1 (screw 2) according to **Requirement**. Make sure that the eccentricity of bush 1 faces downwards.

## Requirement

1. The slot in bearing **3** (see arrow) must be visible from below and there should be a slight but still noticeable amount of backlash between gears **5** and **7**.
2. When the hook is resting lightly on the spinning disc **4** and the point of the hook is positioned towards the centre of the needle, there must be a clearance of **0.05 – 0.1 mm** between the point of the hook and the needle groove.
3. Gear **5** should be in alignment with gear **7**.

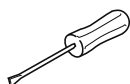
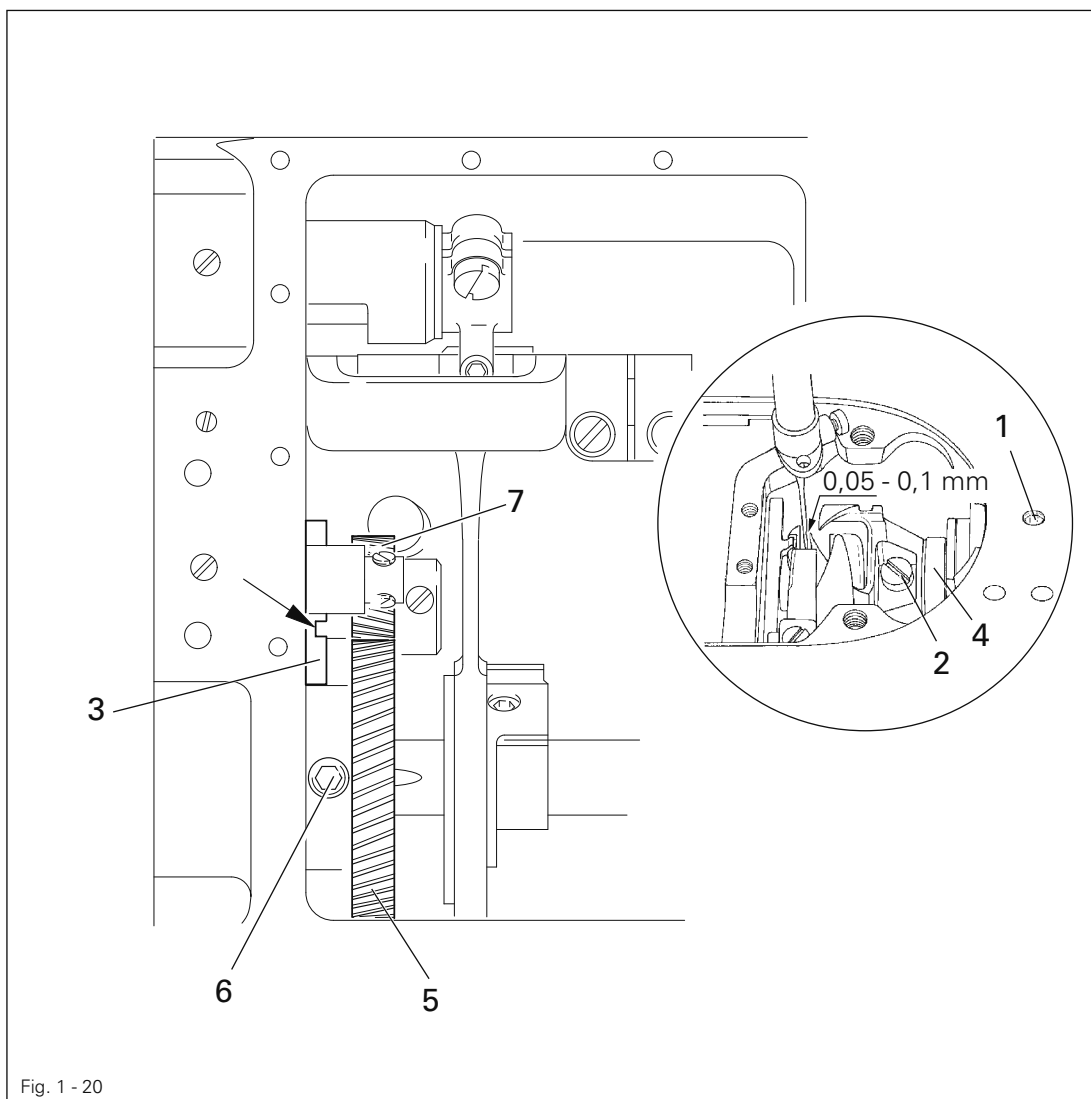

- Loosen screws **1** and **2**.
- Adjust bearing **3** according to **requirement 1**.
- Bring hook into light contact with spinning disc **4**, adjust bearing **3** according to **requirement 2**, without distorting it, and tighten screw **1**.
- Adjust gear **5** (screws **6**) according to **requirement 3**.



## 1.06.19 Final adjustment of needle rise, needle height, and bobbin case position finger

### Requirement

With the stitch length set at "0" and the needle bar in position **1.8 mm past b.d.c.** (adjustment hole "4")

1. the hook point must be at the needle centre and the top of the needle eye **0.8 mm** below the hook point, and
2. there must be a clearance of **0.5 mm** between position stop 3 and the inside of the position slot.

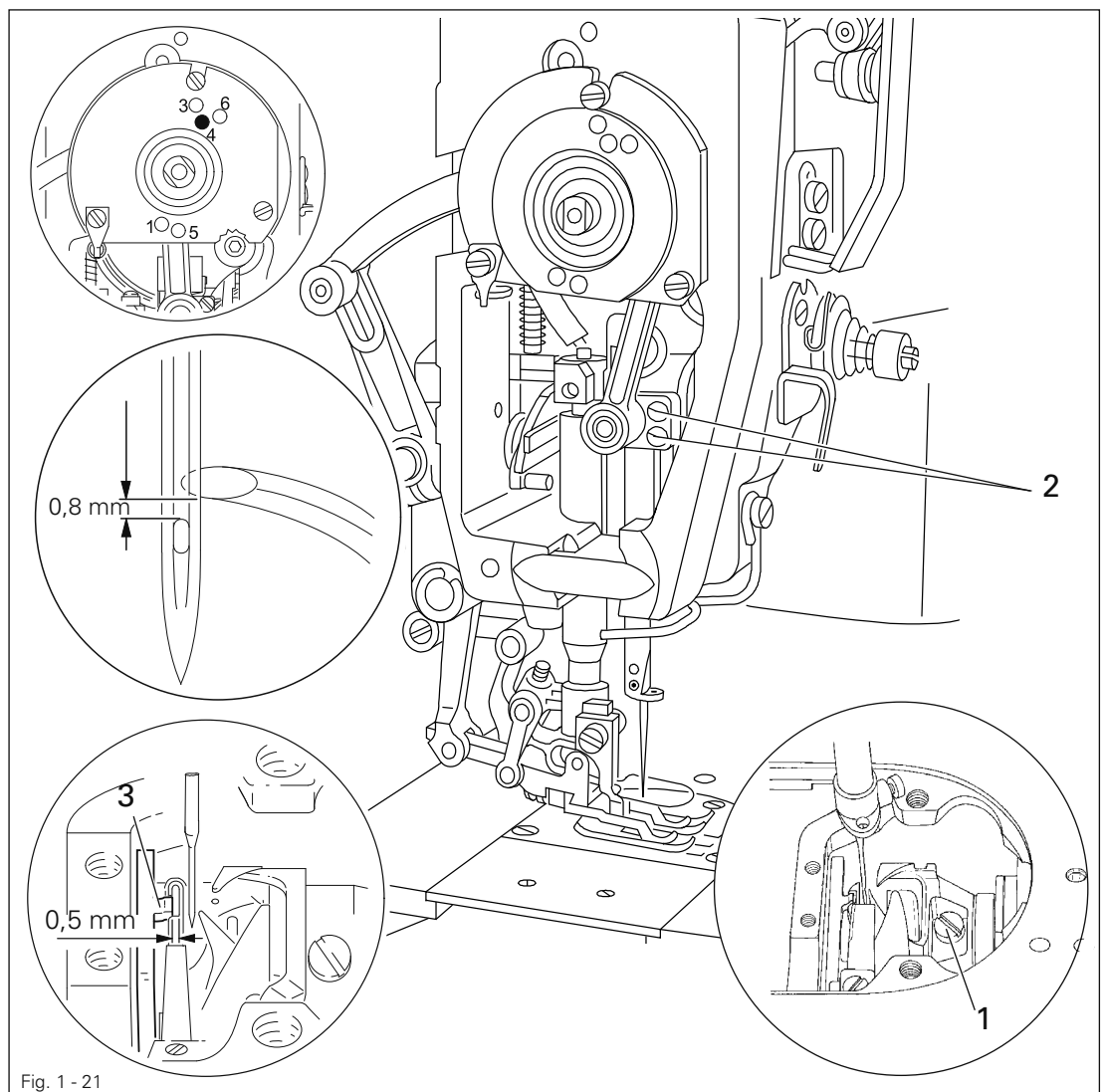
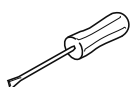

Fig. 1 - 21



- Adjust the sewing hook (screws 1), without shifting it, and needle bar (screws 2), without turning it, according to **Requirement 1**.
- Set the dog of position stop 3 in the slot of the hook base, position it according to **Requirement 2** and secure it in place.

# Adjustment

## 1.06.20 Bobbin case opener height

### Requirement

When bobbin case opener **3** is at its left reversal point the top side of its finger must be **0.5 mm** above the lower edge of bobbin case trip **4**.

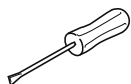
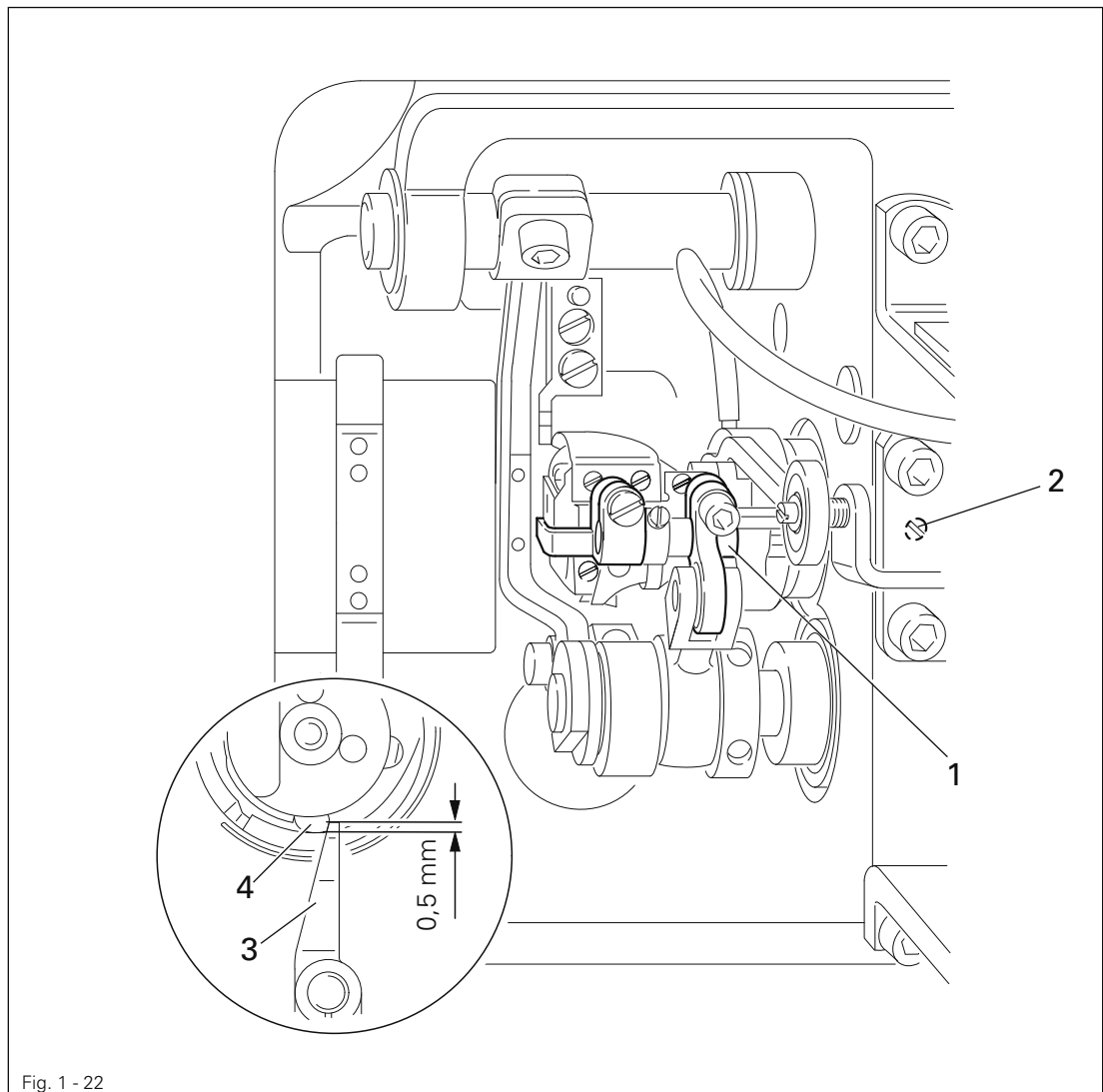

- Turn bobbin case opener bearing **1** (screws **2**) according to **Requirement**.

## 1.06.21 Adjustment of the bobbin opener

### Requirement

1. The distance between the finger of the bobbin opener **3** and the edge of the bobbin case base **5** must be **0.8 mm**.
2. When the bobbin opener **3** is at its left point of reversal, the bobbin case base **5** should be deflected by approx. **0.3 mm** by the retaining finger and screw **1** should be resting on stop pin **7**.

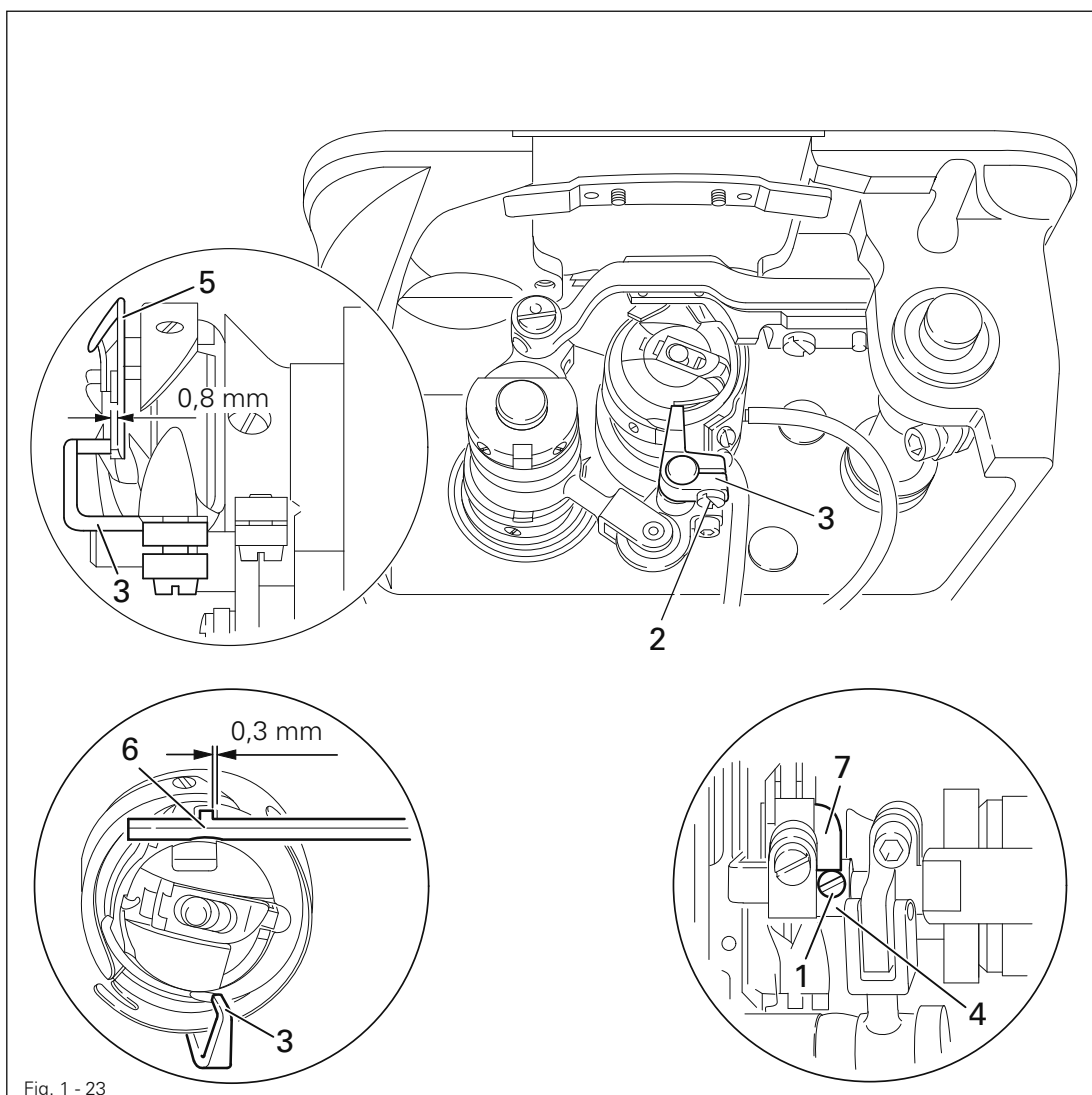
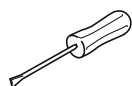

Fig. 1 - 23



- Loosen screw **1** and loosen screw **2** so that the bobbin opener **3** is still held slightly.
- Adjust bobbin opener **3** according to **requirement 1**.
- Tighten screw **2**.
- Adjust retaining collar **4** according to **requirement 2**.
- Tighten screw **1**.

# Adjustment

## 1.06.22 Bobbin case opener motion

### Requirement

When the needle bar is in position **1.8 mm past b.d.c.** (adjustment hole "4"), bobbin case opener **3** must be in its far right position.

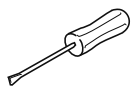
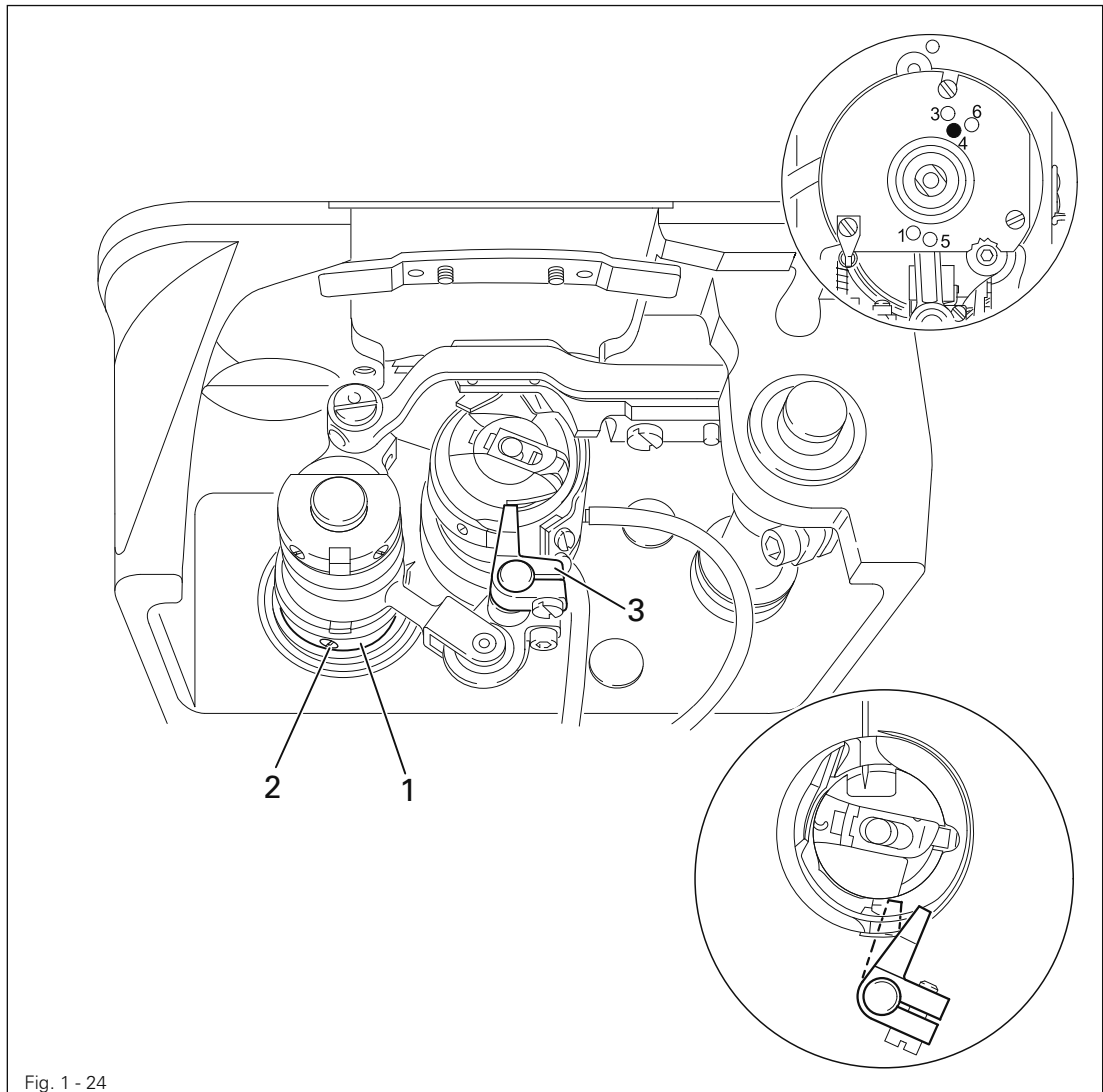

- Adjust bobbin case opener eccentric **1** (screws **2**) according to **Requirement**.

## 1.06.23 Needle thread tension release

### Requirement

When presser bar lifter 3 is raised, the tension disks must be at least 0.5 mm apart.

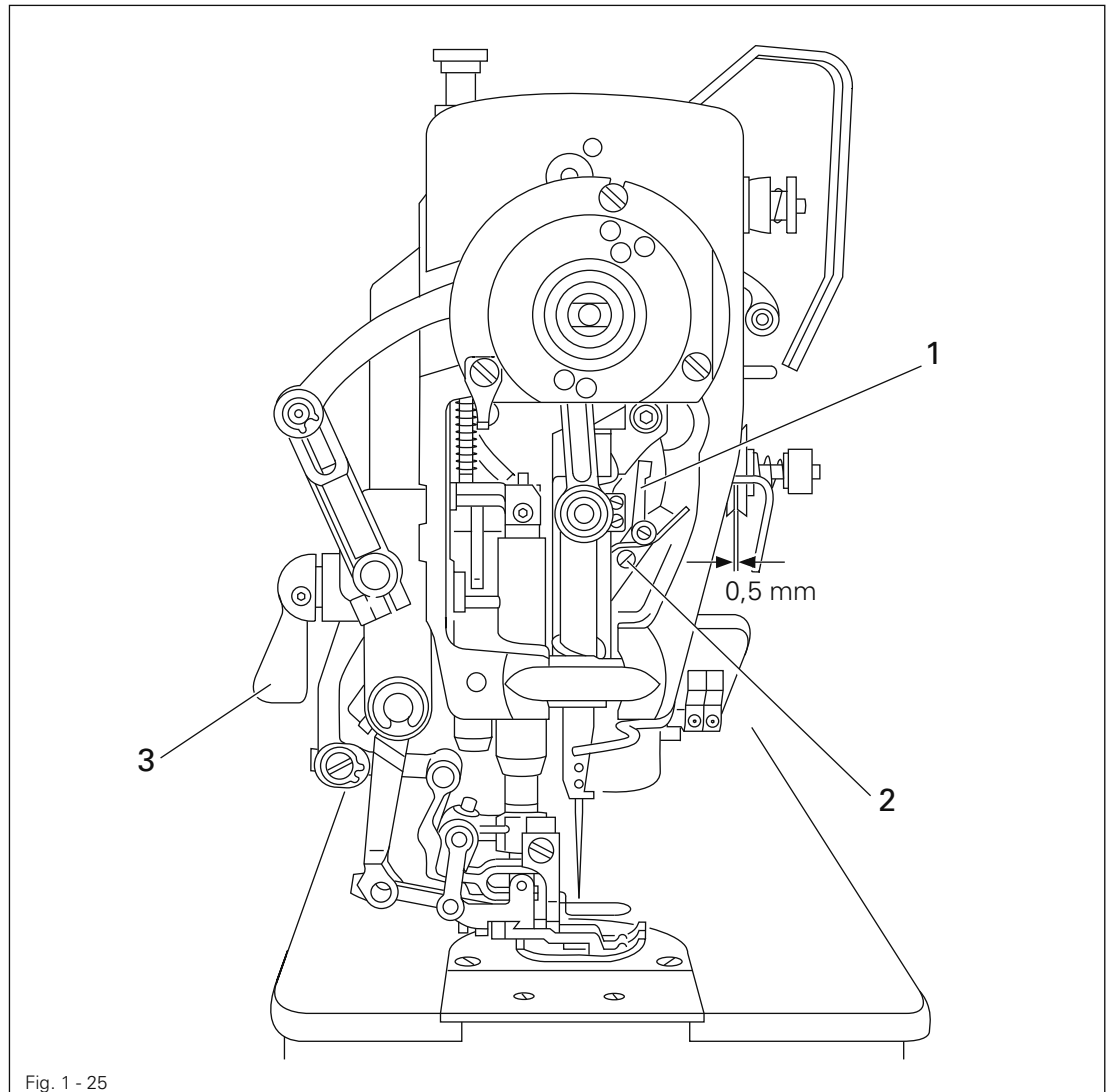
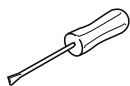

Fig. 1 - 25



- Adjust tension release lever 1 (screw 2) according to **Requirement**.
- Lower the presser foot onto the needle plate; the tension must now be fully activated.

## 1.06.24 Thread check spring and thread regulator

### Requirement

1. The stroke of thread check spring **3** must be completed when the needle point enters the material (spring stroke roughly **7 mm**).
2. Thread regulator **4** must be fixed in its elongated hole so that thread check spring **3** has moved by about **1 mm** when the hook has widened the thread loop to its maximum.

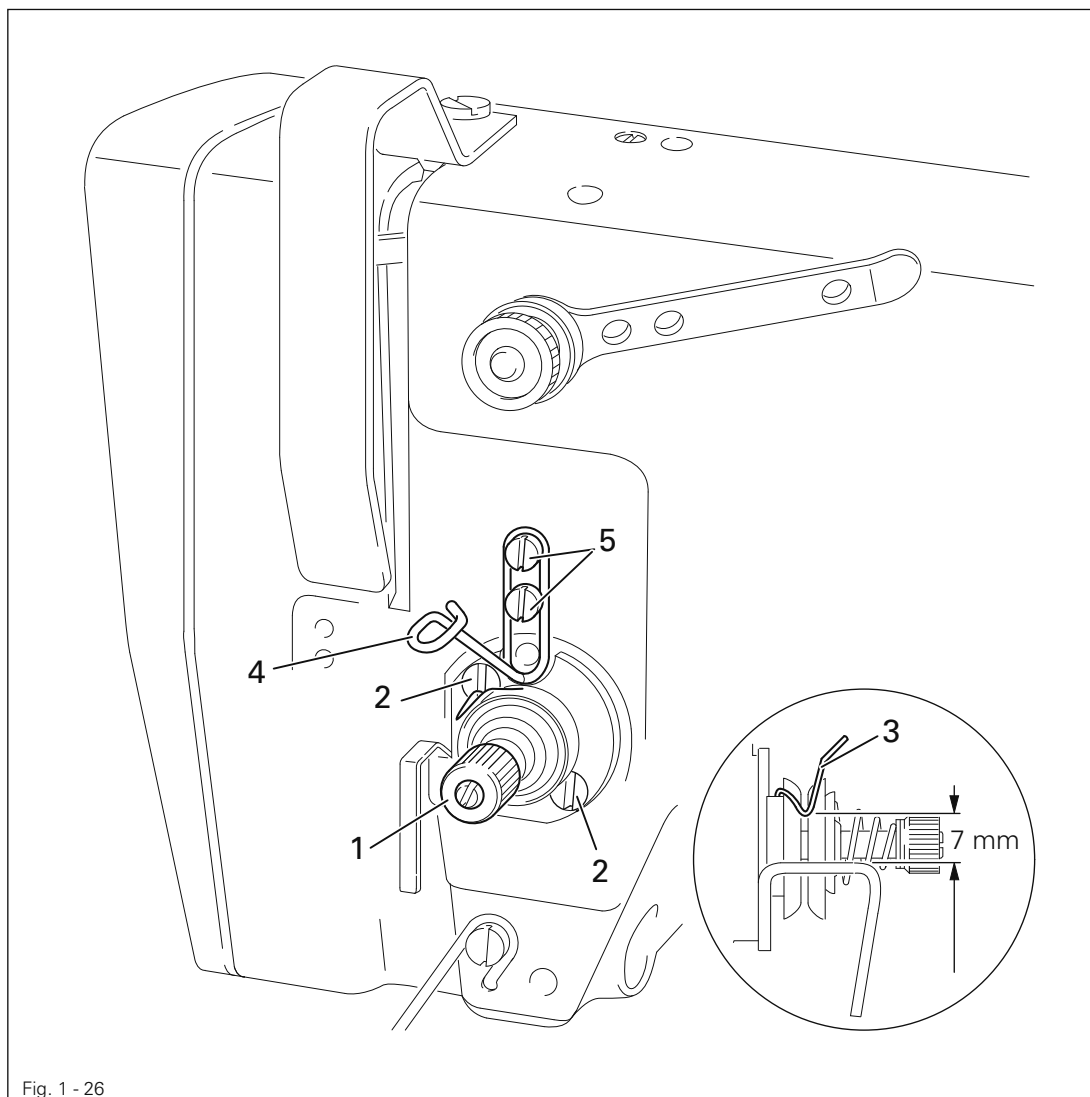
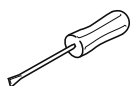

Fig. 1 - 26



- Turn thread tension **1** (screws **2**) according to **Requirement**.
- Shift thread regulator **4** (screws **5**) fully upwards.



The stroke of thread check spring **3** and the position of thread regulator **4** depend on the type of thread and material used and should be adjusted according to the appearance of the seam.

## 1.06.25 Bobbin winder

### Requirement

1. When the bobbin winder is engaged the winder spindle must be driven reliably, but when it is disengaged, friction wheel **5** must not rest against drive wheel **1**.
2. The bobbin winder must switch itself off when the amount of thread wound is about **1 mm** from the edge of the bobbin.

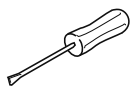
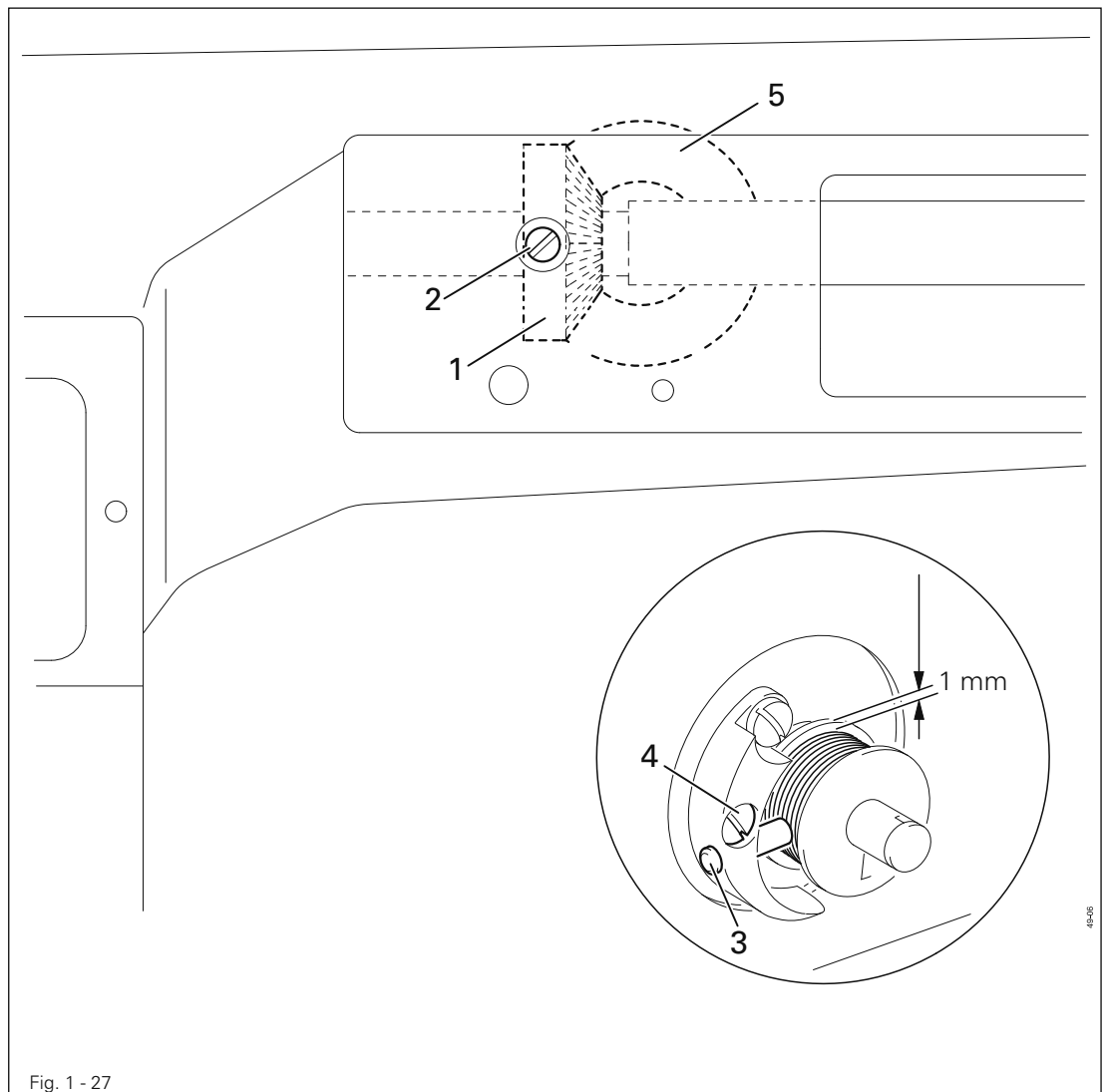

- Position drive wheel **1** (screws **2**) according to **Requirement 1**.
- Place a bobbin on the bobbin winder, thread the bobbin and switch on the winder.
- To adjust the amount of thread wound, position adjusting pin **3** (screws **4**) according to **Requirement 2**.

## 1.06.26 Knee lever resting position

### Requirement

When in its resting position, knee lever linkage 2 must be roughly at right angles to the bedplate.

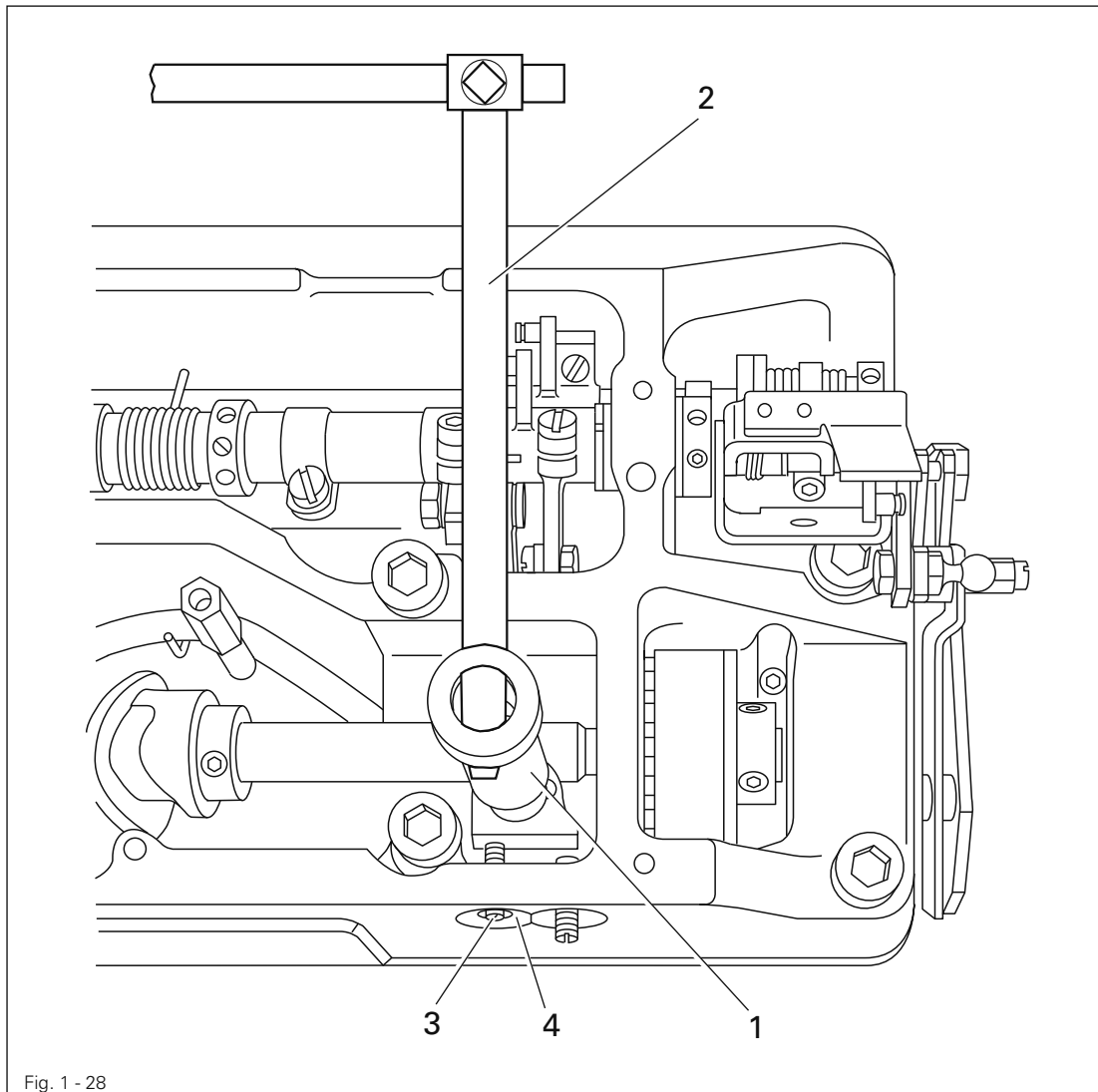
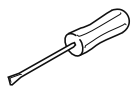

Fig. 1 - 28



- Raise the presser foot using the presser bar lifter
- Fit knee-lever coupling 1 on the knee-lever shaft and snap linkage 2 into knee lever coupling 1.
- Turn stop screw 3 (nut 4) according to Requirement.



## 1.06.27 Knee lever play

### Requirement

When the presser foot is resting on the needle plate there must be a clearance of about **1.3 mm** between lifting lever **3** and lifting piece **4**.

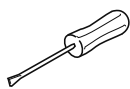
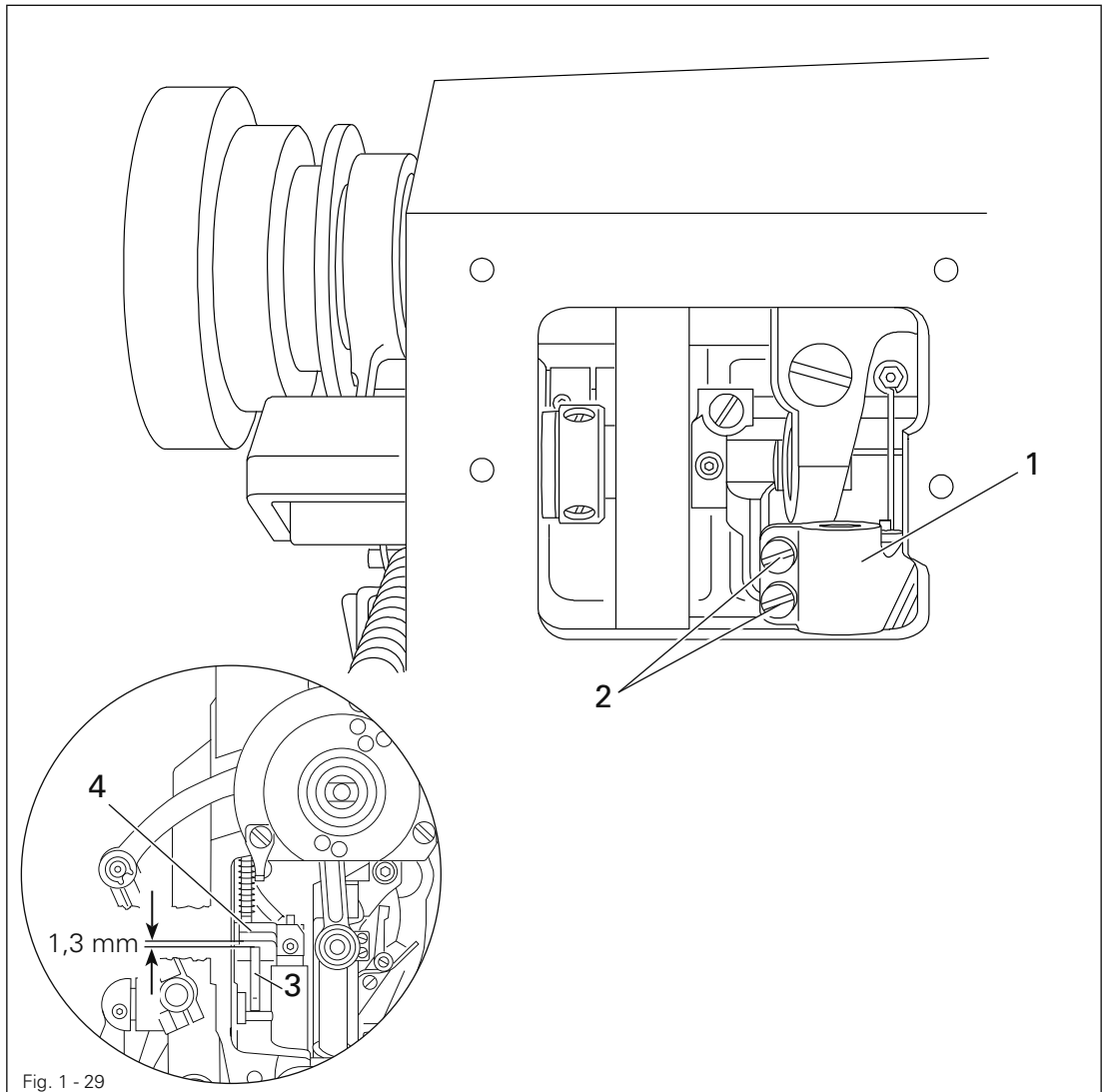

- Set needle bar at b.d.c. and lower presser foot onto needle plate.
- Turn crank **1** (screws **2**) according to **Requirement**.
- Make sure that the vertical knee lever shaft has no vertical play.

## 1.06.28 Knee lever stroke limitation

### Requirement

When the knee lever has been moved to the end stop, there should be a clearance of **9 mm** between the presser foot and the needle plate, and the hand lever should drop down through its own weight.

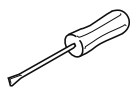
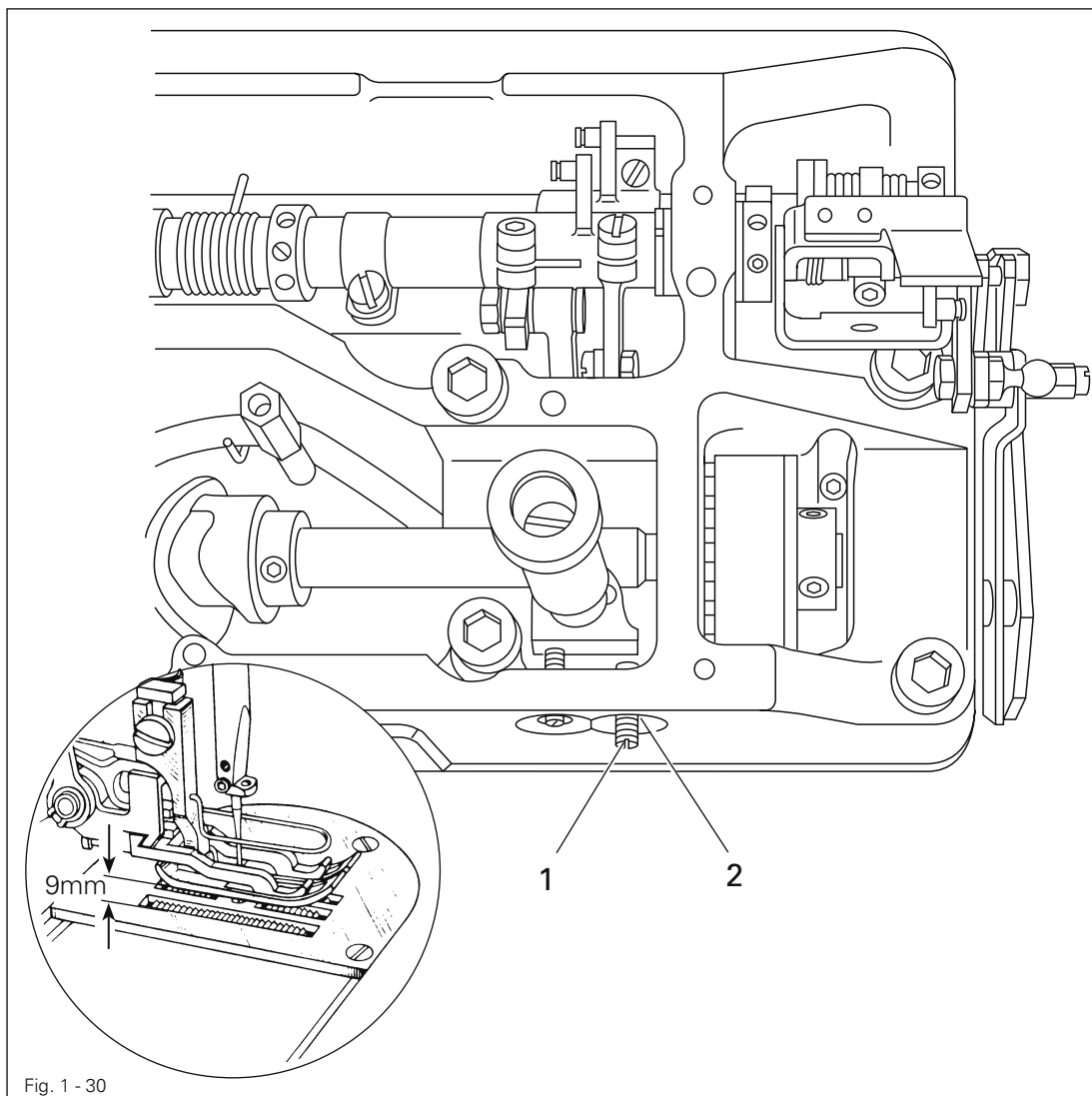

- Unscrew screw 1 (nut 2) a few turns.
- Raise the presser bar lifter
- Place the **9 mm** thick part of the feeler gauge under the presser foot and lower the presser bar lifter.
- Making sure that the presser foot does not lift off the feed dog gauge, press the knee lever fully to the right and hold it there.
- Turn screw 1 fully in and then back out by a half turn.
- Tighten nut 2.

## 1.06.29 Position of vibrating presser in relation to lifting presser

### Requirement

When the presser foot is raised with the presser bar lifter and the take-up lever is in its highest position, the teeth of vibrating presser **3** must not protrude below the shoe of lifting presser **4**.

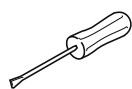
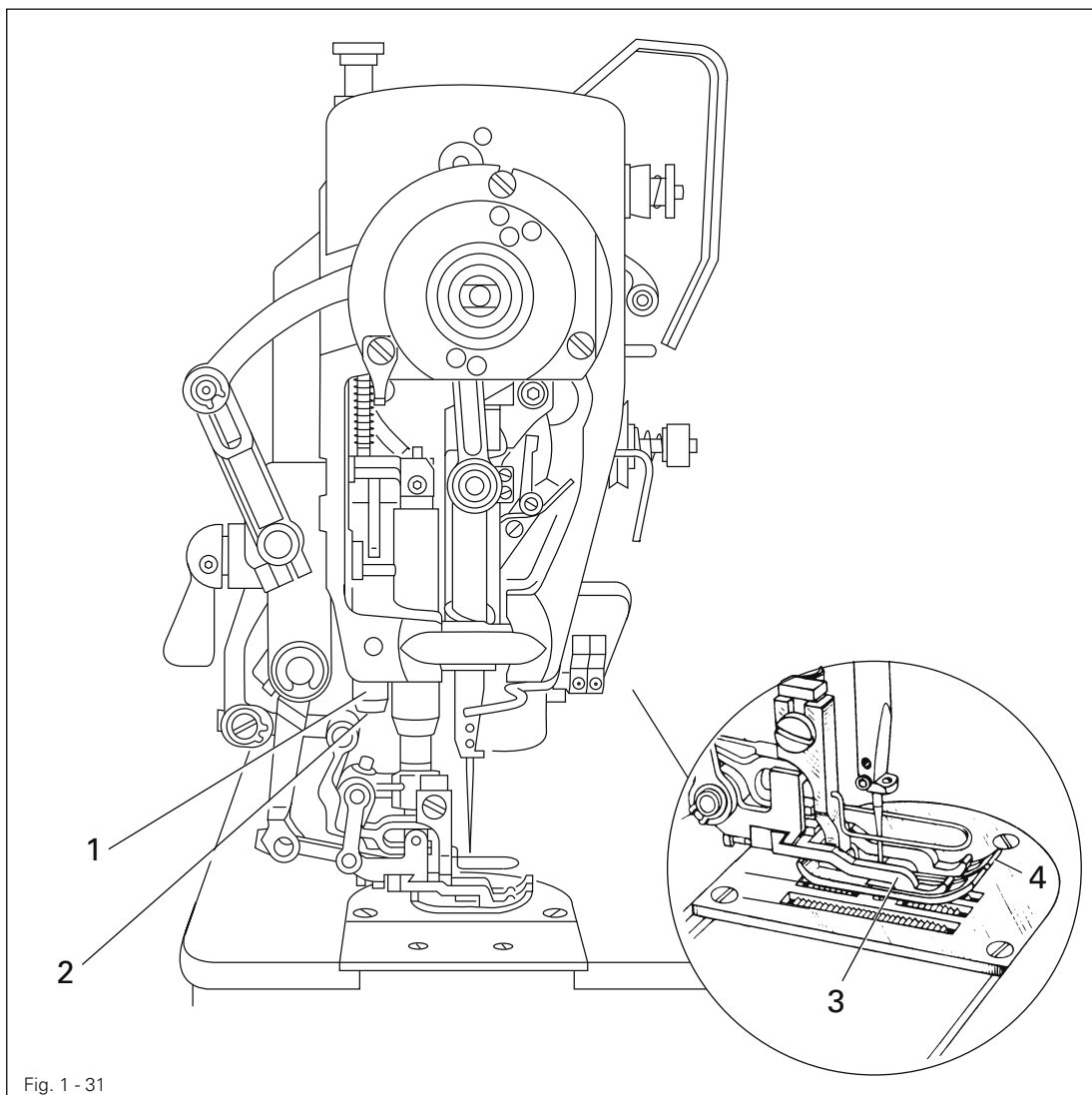

- Turn eccentric sleeve **1** (screw **2**) according to Requirement.

## 1.06.30 Pressure of the vibrating- and lifting pressers

### Requirement

Even at the highest sewing speed the material must still be fed reliably, but there must not be any pressure marks on the material.

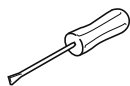
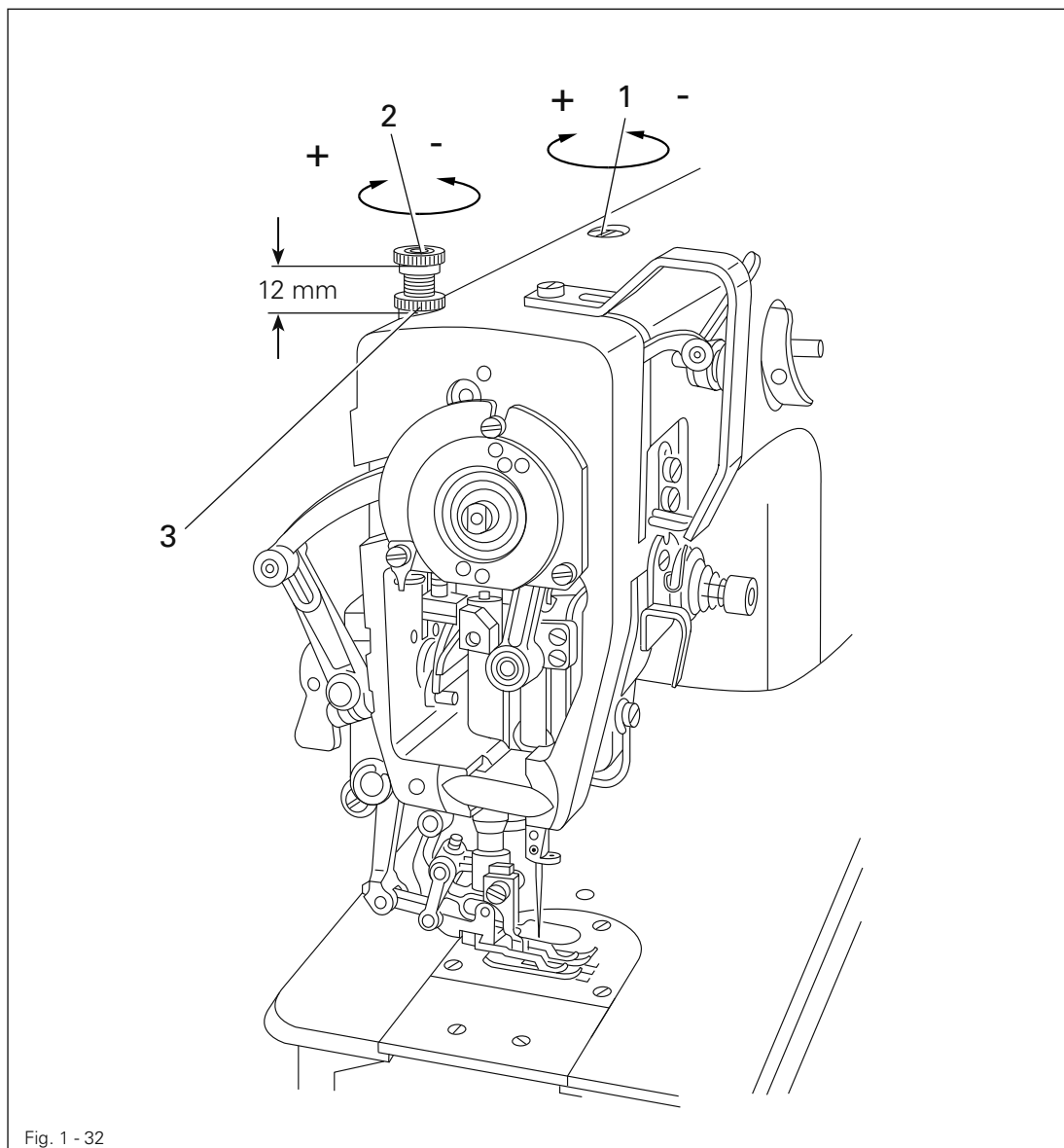

- Set regulating screw 1 for the pressure of the vibrating presser flush with the top surface of the housing.
- Turn regulating screw 2 (nut 3) for the pressure of the lifting presser so that its shoulder is at a distance of about 12 mm from the machine housing.



It may be necessary to increase (+) or decrease (-) the pressure of the vibrating- or lifting presser.

## 1.06.31 Stitch length limitation

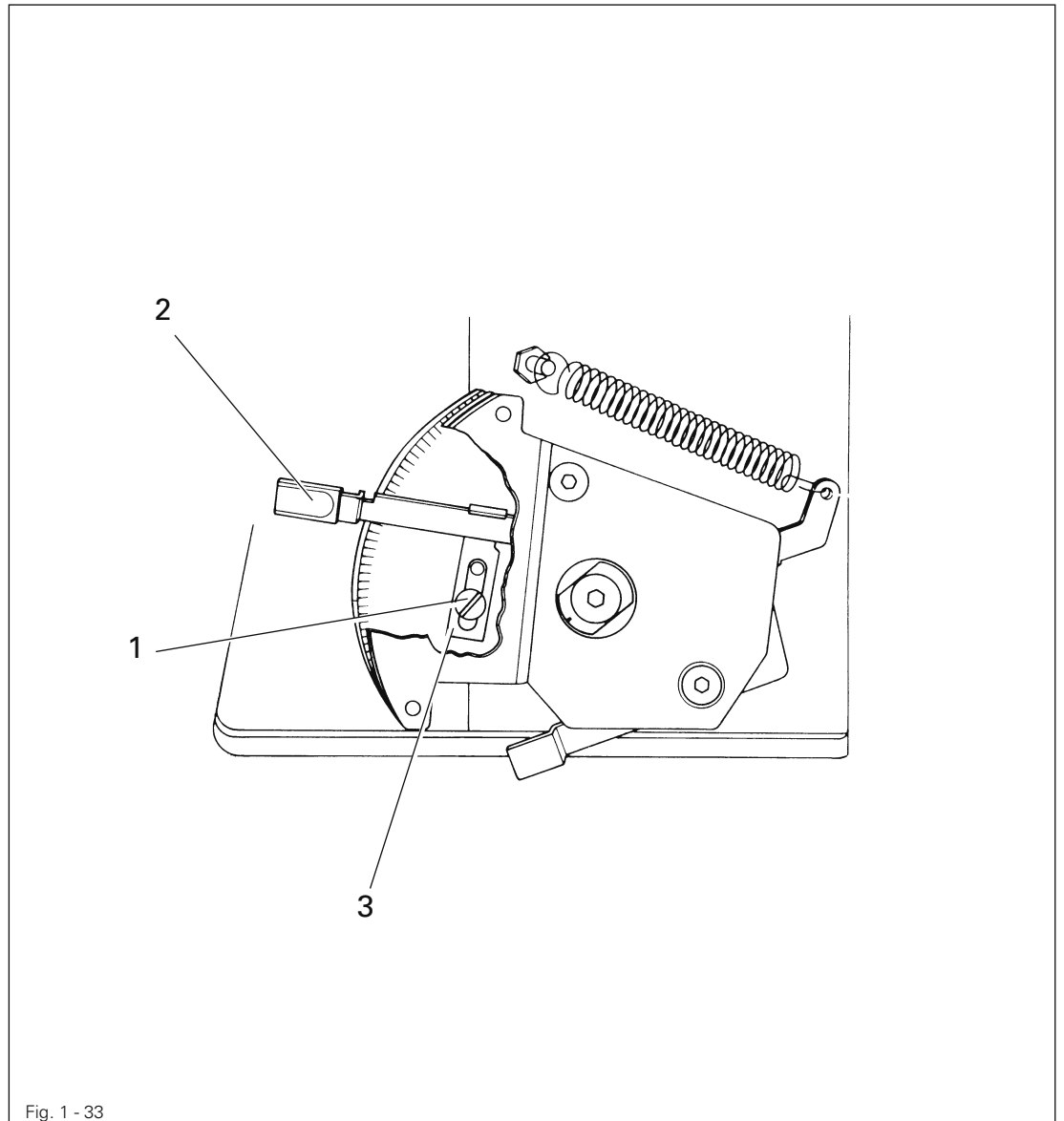

Fig. 1 - 33

- Loosen or, depending on the amount of limitation, take out screw **1** (accessible through the fitting window).
- Set feed regulator lever **2** to the required maximum stitch length.
- Place limitation stop **3** onto regulator lever **3** and secure it with screw **1** in the top or bottom hole (depending on the amount of limitation).

# Adjustment

## 1.07 Parameter settings (only on machines with EcoDrive and control unit P40 ED)

Parameter settings are described in the separate operations manual for the drive, and may only be changed by qualified technicians!

### 1.07.01 Parameter list

Group	Parameter	Description	User level	Setting range	Set value
1	105	Speed for start backtackl	B, C	300 - 2000	1200
	110	Speed for end backtack	B, C	300 - 2000	1200
6	606	Speed min.	B, C	30 - 300	180
	607	Speed max.	B, C	300 - 6000	▲
	609	Cutting speed	B, C	60 - 300	180
	660	Bobbin thread control 0 = off, 1 = thread monitor, 2 = reverse counter	A, B, C	0 - 2	0
7	700	Needle position 0 Needle reference position	B, C	0 -255	*
	702	Needle position 1 (needle lowered)	B, C	0 - 255	90
	703	Needle position 2 (take-up lever raised)	B, C	0 - 255	236
	705	End cutting signal	B, C	0 - 255	200
	706	Start cutting signal	B, C	0 - 255	136
	707	Needle position 9 (start thread tension release/start thread catcher)	B, C	0 - 255	164
	760	Multiplier for the fixed value (200) stitch count	A,B, C	0 - 250	5
	799	Selected machine class	C	1 - 3	1
8	800	Rotating direction of the motor	C	0 - 1	1

▲ See Chapter 3 **Specifications** (in the machine instruction manual).

\* Adjustment see Chapter 8.05 **Basic position of the machine drive unit** (in the machine instruction manual).



Further parameters and the description for an internet update of the machine software and reset /cold start of the machine can be found in the instruction manual for the drive

2 Circuit diagrams

2.01 Reference list for the Circuit diagrams 91-191 501-95

A1	Control unit P40 ED
A2	Control panel BDF S3
A14	Sewing head recognition system (OTE)
H1	Sewing lamp (optional)
H10	LED stitch counter
M1	Sewing motor
Q1	Main switch
S1	Manual backtacking key
S1.1	Pedal speed control unit
S6	Start inhibitor (E6 stop)
X0	PC-interface (RS 232)
X1	Motor
X2	Incremental transducer
X2.1	Incremental transmitter adapter
X2.2	Synchronizer adapter
X2.3	Y5-911/.. backtacking device
X3	Speed control unit
X3.1	Y2 thread trimmer -900/..
X4	A2 Control panel BDF S3
X4.1	Y4 automatic foot lift ( -910/.. )
X5	Out-/input
X5.1	S1 Manual backtacking key
X6	Bobbin thread monitor (optional)
X7	Photoelectric barrier (optional)
X8	Y8 thread tension release (FSL)
X22	Y2 thread trimmer -900/..
X24	Y4 automatic foot lift ( -910/.. )
X25	Y5 backtacking device ( -911/.. )
X28	Y8 thread tension release (FSL)
X50	A14 Sewing head recognition system (OTE)
Y2	thread trimmer -900/.
Y4	automatic foot lift ( -910/.. )
Y5	backtacking device ( -911/.. )
Y8	thread tension release (FSL)

2.02

Circuit diagrams 91-191 501-95

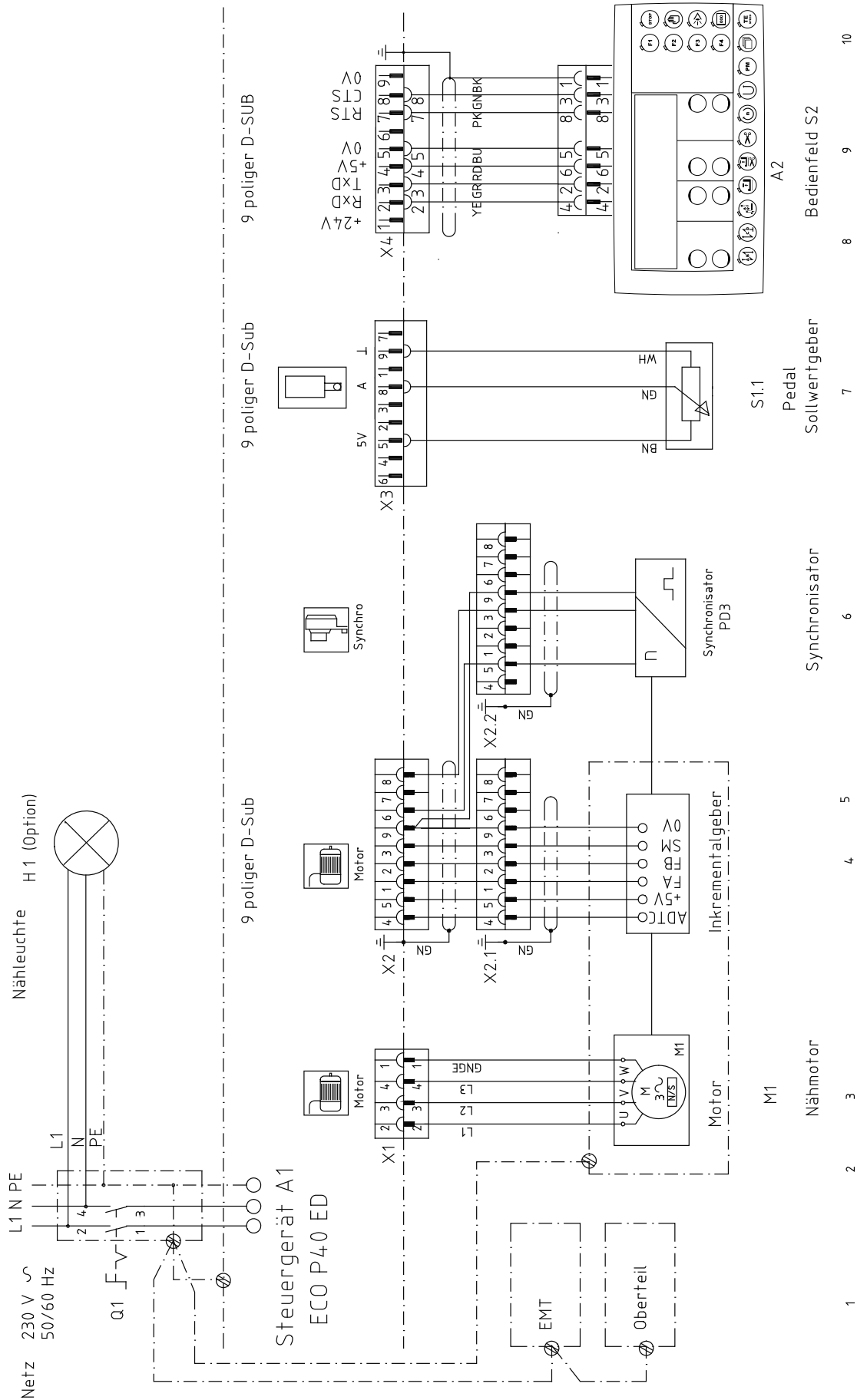



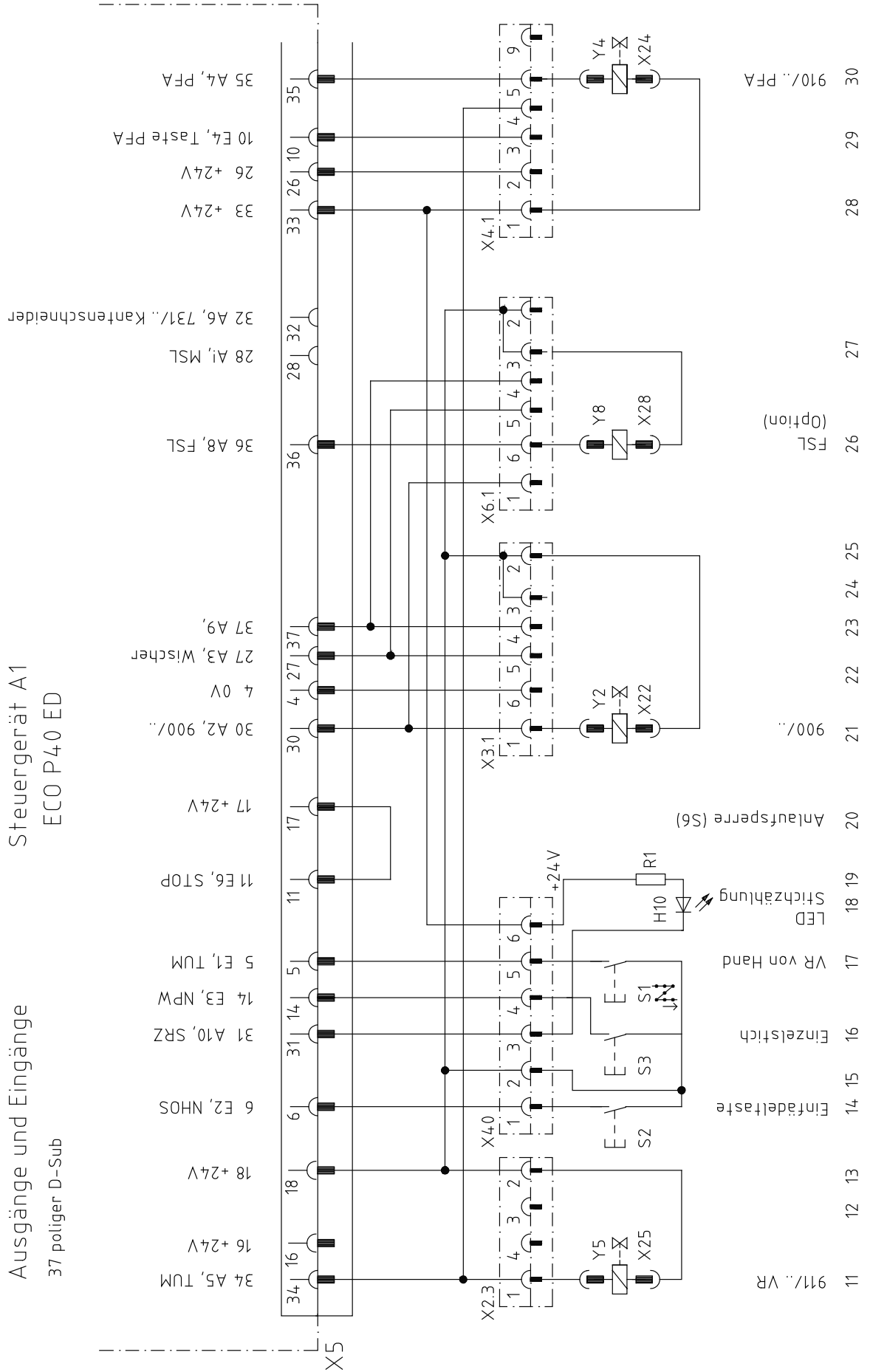

Steuergerät A1 ECO P40 ED

Sonderfunktionen

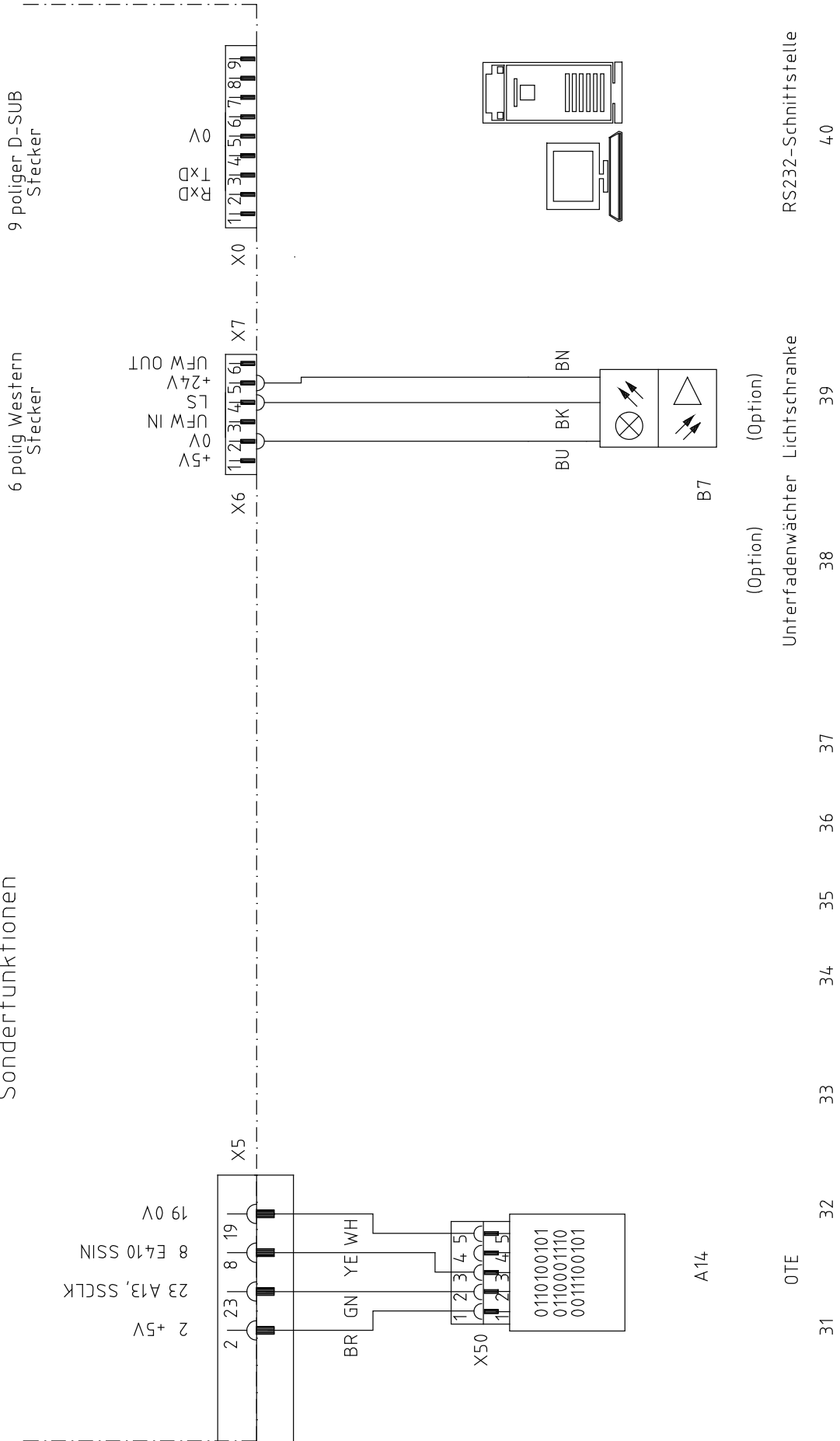





**Europäische Union**  
Wachstum durch Innovation – EFRE



## PFAFF Industriesysteme und Maschinen AG

Hans-Geiger-Str. 12 - IG Nord  
D-67661 Kaiserslautern

Telefon: +49-6301 3205 - 0  
Telefax: +49-6301 3205 - 1386  
E-mail: [info@pfaff-industrial.com](mailto:info@pfaff-industrial.com)