

POWERline

2545

2546

ADJUSTMENT MANUAL

This Adjustment Manual is valid for machines
from the following serial numbers onwards:

7 250 050 →

The reprinting, copying or translation of PFAFF Service Manuals, whether in whole or in part, is only permitted with our previous authorization and with written reference to the source.

**PFAFF Industriesysteme
und Maschinen AG**

Hans-Geiger-Str. 12 - IG Nord
D-67661 Kaiserslautern

	Contents	Page
1	Adjustment	5
1.01	Notes on adjustment	5
1.02	Tools, gauges and other accessories for adjusting	5
1.03	Abbreviations	5
1.04	Explanation of the symbols.....	5
1.05	Adjusting the basic machine	6
1.05.01	Basic position of the balance wheel (adjustment aid).....	6
1.05.02	Balance weight	7
1.05.03	Zero position of the unison feed	8
1.05.04	Feeding motion of the unison feed	9
1.05.05	Lifting motion of the bottom feed dog	10
1.05.06	Height of the bottom feed dog	12
1.05.07	Feeding stroke difference	13
1.05.08	Preliminary adjustment of the needle height.....	14
1.05.09	Needle rise, hook clearance, needle height and needle guard	15
1.05.10	Top feed stroke	17
1.05.11	Top-feed lifting motion	18
1.05.12	Adjusting the potentiometer for speed reduction.....	19
1.05.12.01	On machines with drive P74 ED-L.....	19
1.05.12.02	On machines with drive PF 321	19
1.05.13	Bobbin case opener stroke	20
1.05.14	Adjusting the shortened trim stitch.....	21
1.05.15	Bobbin winder.....	22
1.05.16	Thread check spring and thread regulator	23
1.05.17	Sewing foot pressure.....	24
1.05.18	Lubrication	25
1.05.19	Limiting the stitch length	26
1.05.20	Speed reduction.....	27
1.05.21	Re-engaging the slip-clutch.....	28
1.06	Adjusting the thread trimmer -900/81	29
1.06.01	Resting position of roller lever/radial position of control cam	29
1.06.02	Position and height of the thread catcher	30
1.06.03	Knife pressure.....	31
1.06.04	Bobbin thread clamp spring	32
1.06.05	Manual cutting test	33

	Contents	Page
	Contents	Page
1.07	Adjusting the thread trimmer device -900/82	35
1.07.01	Preliminary testing	35
1.07.02	Assrémby of the thread clamp carrier and thread catcher	35
1.07.03	Check settings according to the following chapter:	35
1.07.04	Needle position in sewing direction.....	36
1.07.05	Bottom transporter in sewing direction	37
1.07.06	Blade position	38
1.07.07	Thread catcher height	39
1.07.08	Thread catcher position in sewing direction.....	40
1.07.09	Thread catcher position crossways to sewing direction	41
1.07.10	Position of the control curve	42
1.07.11	Thread clamp	43
1.07.12	Parameter values	44
2	Circuit diagrams.....	45
2.01	Block diagram PFAFF 2545 and 2546 BASIC with control pack P45 PD-L	45
2.02	Circuit diagrams PFAFF 2545 and 2546 BASIC.....	46
2.03	Block diagram PFAFF 2545 and 2546 PLUS with control pack P74 ED-L.....	49
2.04	Circuit diagrams PFAFF 2545 and 2546 PLUS	50
2.05	Block diagram PFAFF 2545 and 2546 PLUS with PF 321	55

1 Adjustment



Please observe all notes from Chapter 1 **Safety** of the instruction manual!
In particular care must be taken to see that all protective devices are refitted properly after adjustment, see Chapter 1.06 **Danger warnings** of the instruction manual!



If not otherwise stated, the machine must be disconnected from the electrical power supply. Danger of injury due to unintentional starting of the machine!

1.01 Notes on adjustment

All following adjustments are based on a fully assembled machine and may only be carried out by expert staff trained for this purpose.

Machine covers, which have to be removed and replaced to carry out checks and adjustments, are not mentioned in the text.

The order of the following chapters corresponds to the most logical work sequence for machines which have to be completely adjusted. If only specific individual work steps are carried out, both the preceding and following chapters must be observed.

Screws, nuts indicated in brackets () are fastenings for machine parts, which must be loosened before adjustment and tightened again afterwards.

1.02 Tools, gauges and other accessories for adjusting

- Screwdrivers with blade width from 2 to 10 mm
- Spanners (wrenches) with jaw width from 7 to 14 mm
- 1 set Allen keys from 1.5 to 6 mm
- 1 gauge for the top feed stroke 5.0 mm (Part No. 61-111 633-60)
- 1 feed dog adjustment gauge, Part No. 61-111 689-04
- Metal rule (part No. 08-880 218-00)
- Sewing thread and test materials

1.03 Abbreviations

t.d.c. = top dead centre

b.d.c. = bottom dead centre

1.04 Explanation of the symbols

In this adjustment manual, symbols emphasize operations to be carried out or important information. The symbols used have the following meaning:



Note, information

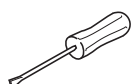

Service, repair, adjustment, maintenance
(work to be carried out by qualified staff only)

Adjustment

1.05 Adjusting the basic machine

1.05.01 Basic position of the balance wheel (adjustment aid)

Requirement

When the needle bar is positioned at t.d.c., the marking "0" on the scale should be level with the top edge of the belt guard (see arrow).

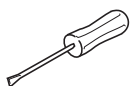
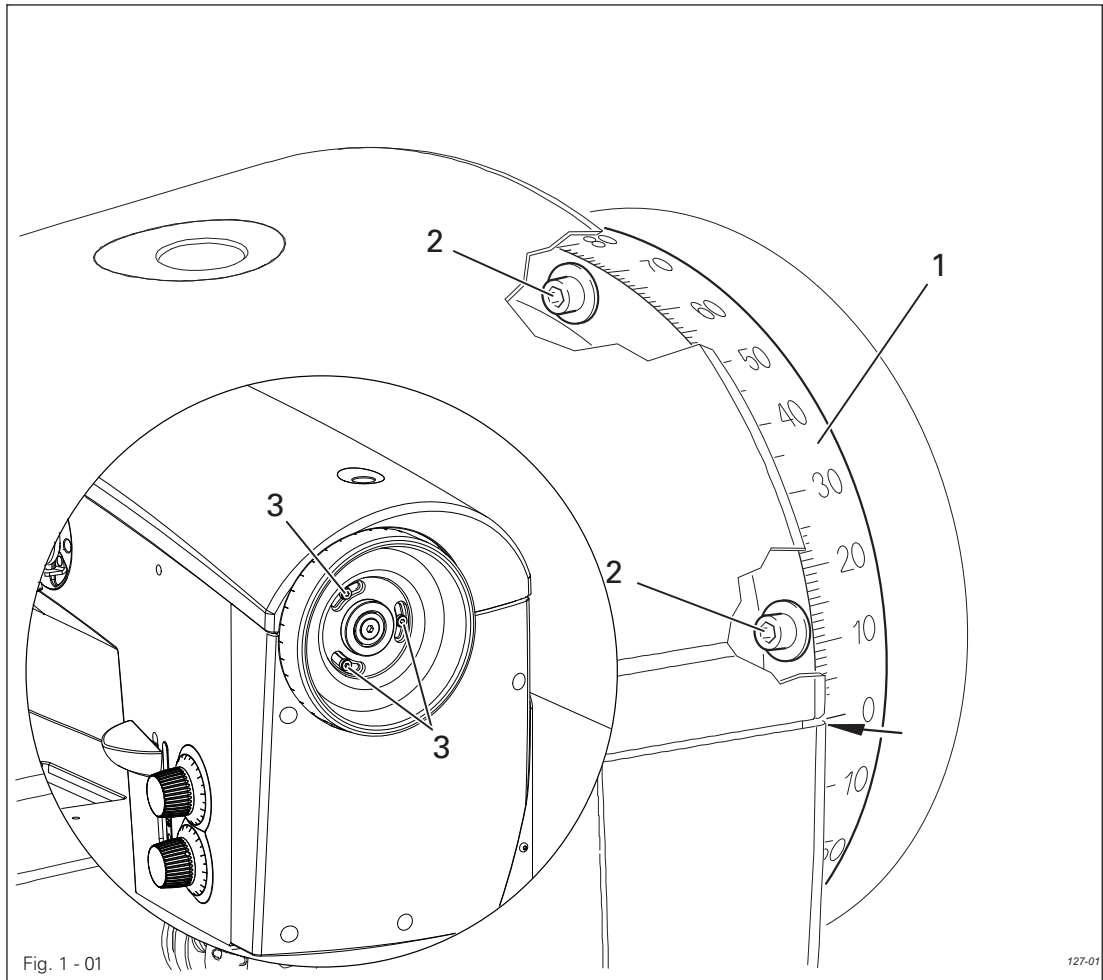

- Adjust the scale dial 1 (depending on model screws 2 or 3) in accordance with the requirement.

1.05.02 Balance weight

Requirement

When the needle bar is positioned at b.d.c. (balance wheel position 180°) the largest eccentricity of the balance weight 1 should be at the top.

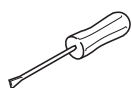
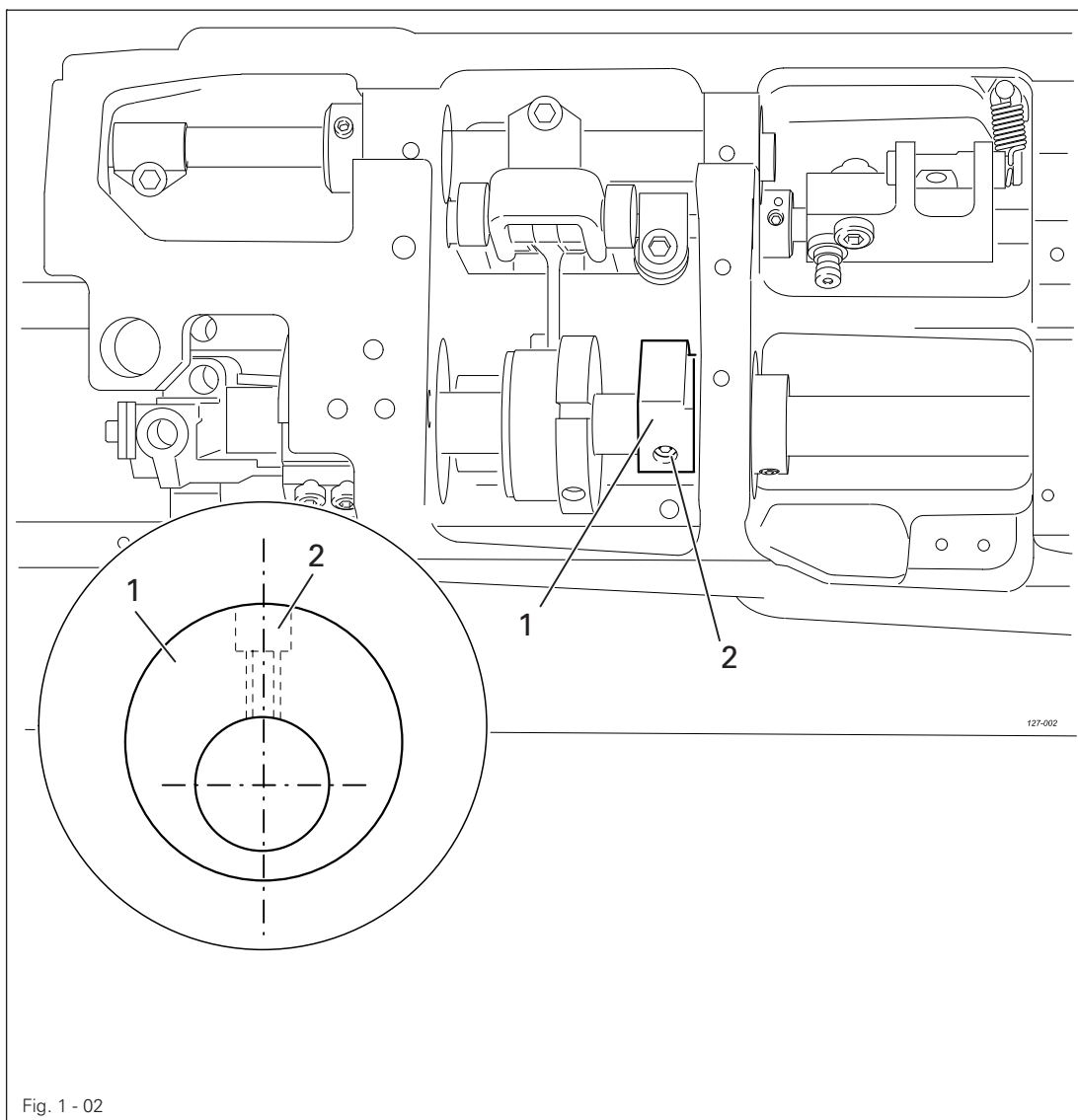

- Adjust balance weight 1 (screw 2) in accordance with the requirement.

Adjustment

1.05.03 Zero position of the unison feed

Requirement

When the stitch length is set at "0", the top and bottom feed dogs and the needle bar should not make any feeding motion when the balance wheel is turned.

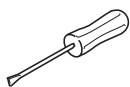
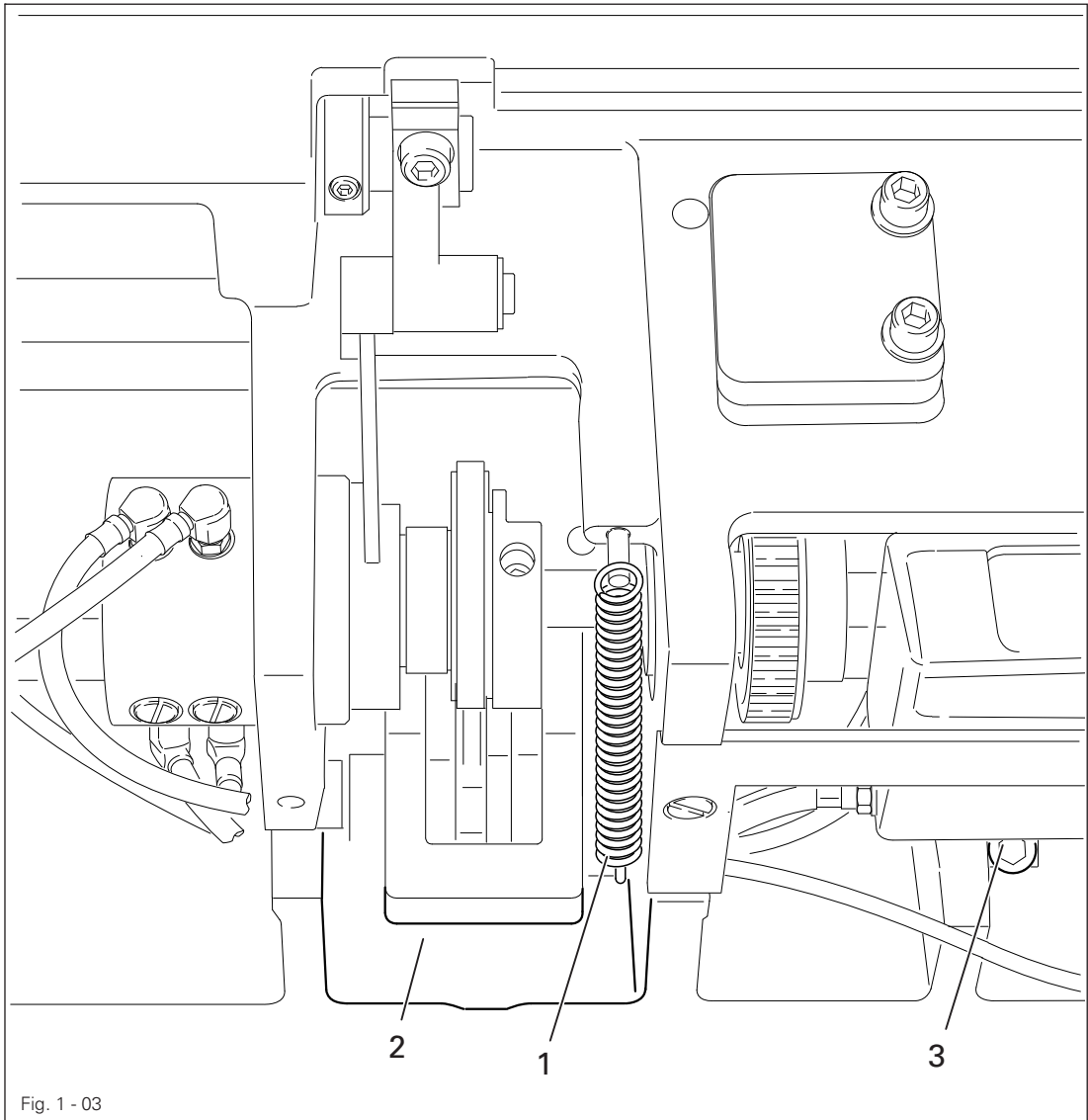

- Remove spring 1.
- Adjust crank 2 (screw 3) in accordance with the requirement.
- Replace the spring 1.

1.05.04 Feeding motion of the unison feed

Requirement

When the needle bar is positioned at b.d.c. (balance wheel position 180°), and the maximum stitch length is set, the top and bottom feed dogs and the needle bar should not make any feeding motion when the reverse-feed lever is pressed.

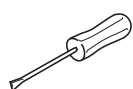
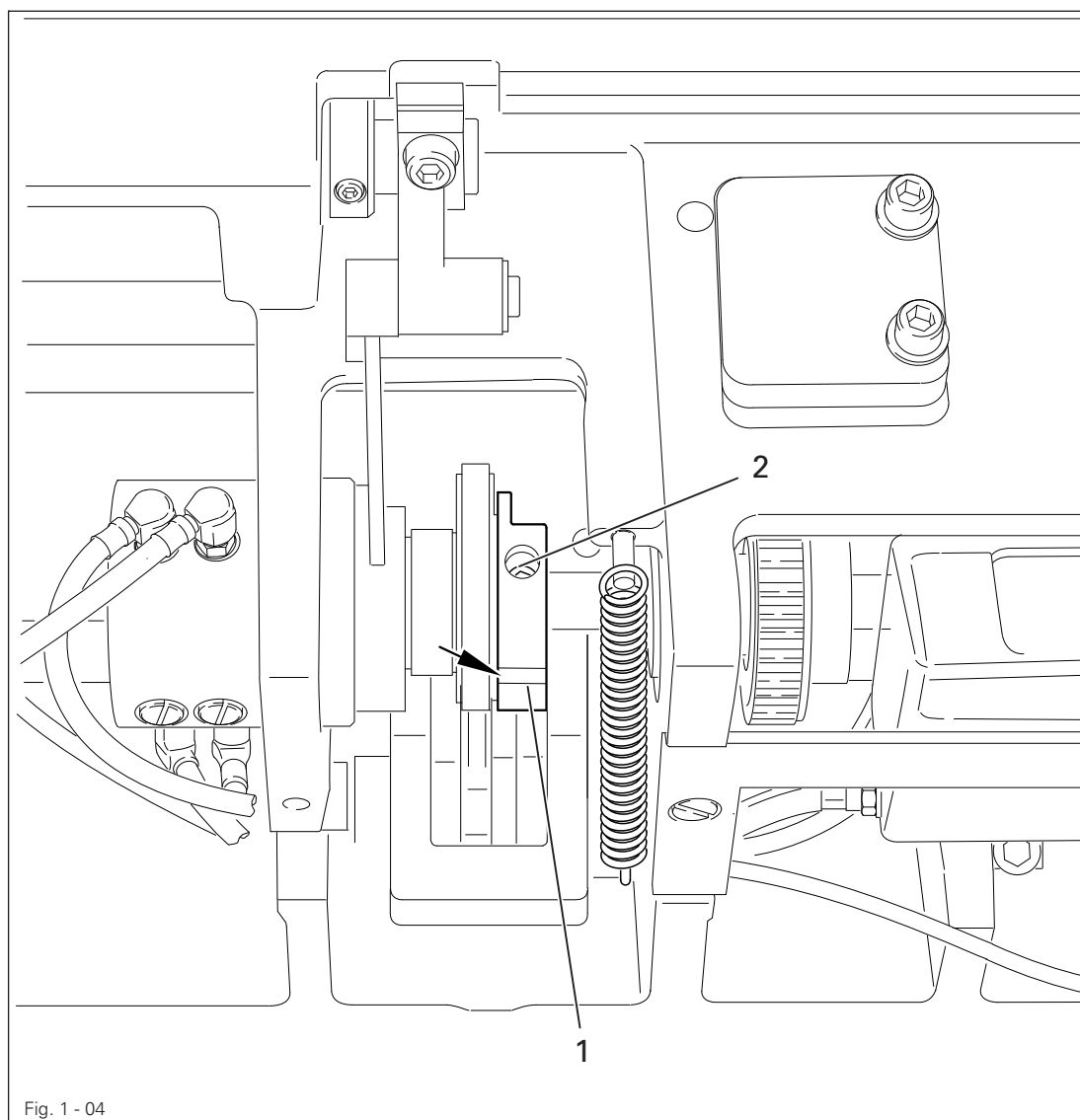

- Adjust eccentric 1 (screws 2) in accordance with the **requirement**. Make sure that the cut-out (see arrow) is visible.

1.05.05 Lifting motion of the bottom feed dog

Requirement

When the balance wheel is positioned at **180°**, the feed dog should be at t.d.c.

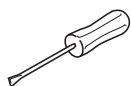
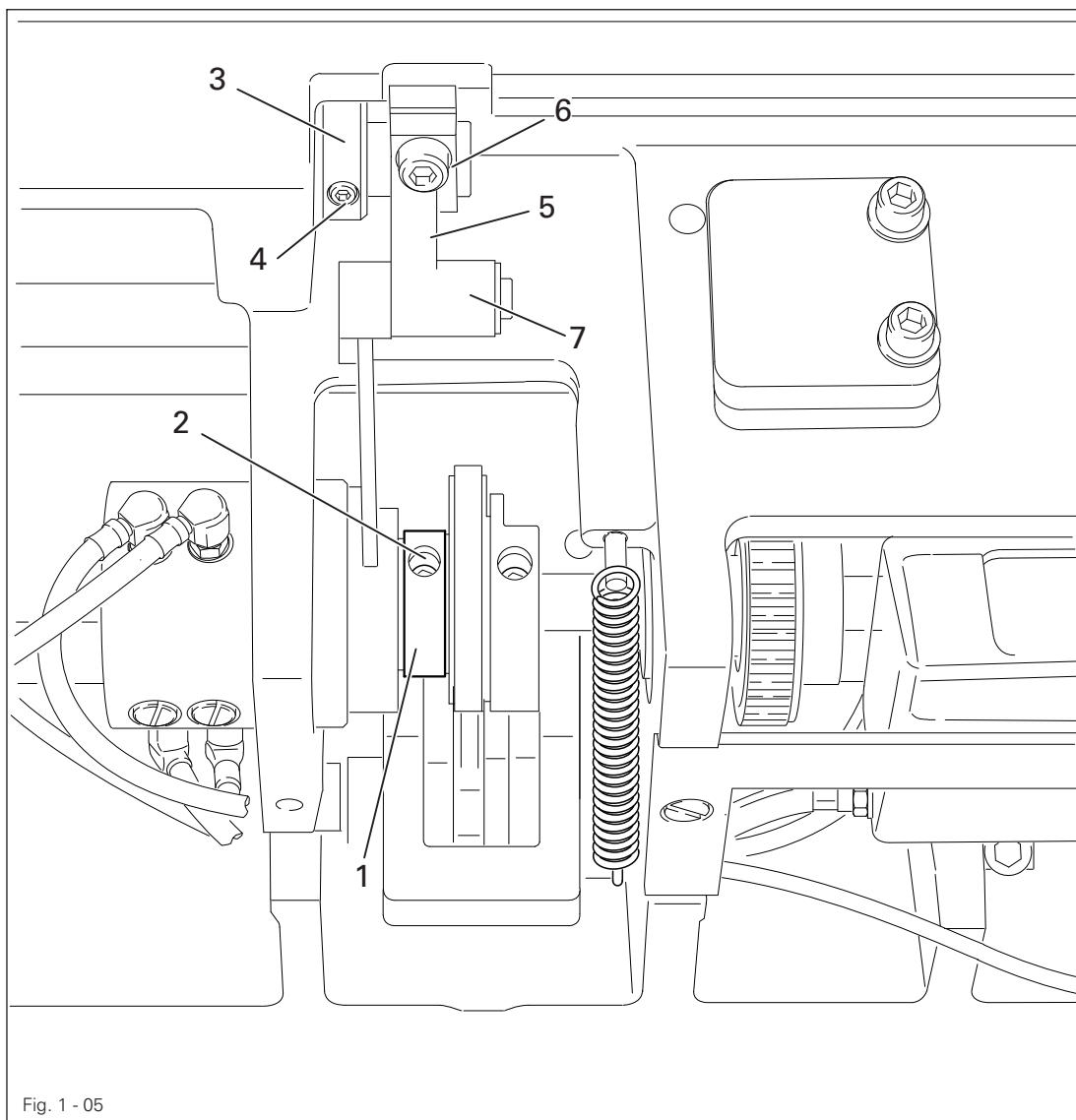

- Adjust eccentric 1 (screws 2) in accordance with the **requirement**.



Use the kit with the Order No. 91-501 399-90 to deactivate the transporter lifting movement.

- Install assembly and adjust
- Remove collar 3 (screws 4) and crank 5 (screw 6, nut 7).
- Mount the preassembled parts of the kit as shown in figures 1 - 05a.
- Adjust bottom transporter height and stroke movement where required.

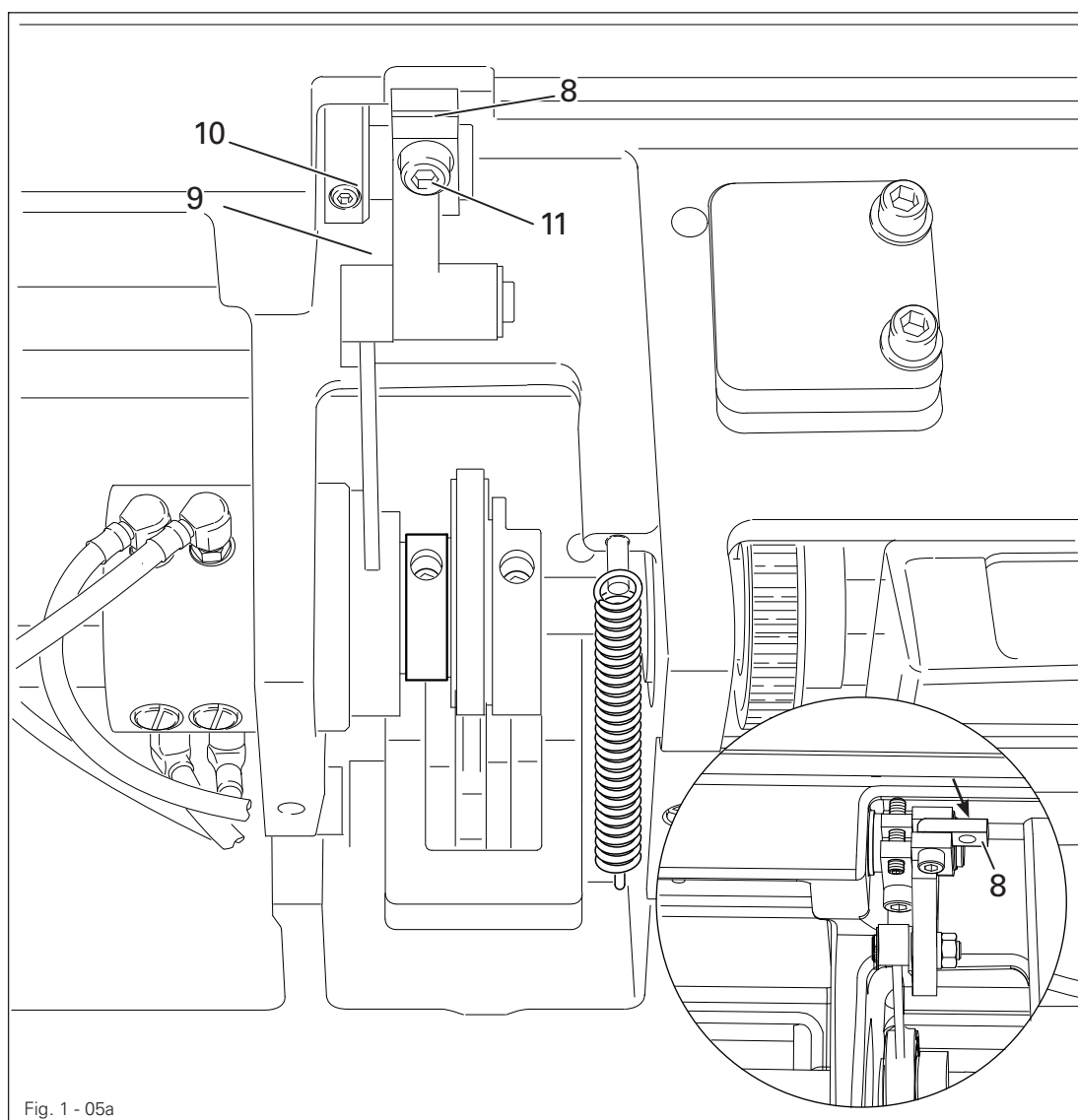
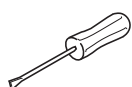

Fig. 1 - 05a



Activate lifting movement

- Lifting movement is activated if connection part 8 is swiveled in as shown in figures 1 - 05a, and screws 9 (M6 x 16) and 10 (M5 x 16) have been attached.

Deactivate lifting movement

- Remove screws 9 and 10 and swivel connection part 8 (screw 11) towards the right.
- Replace screw 9 with a screw M6 x 25.
- Replace screw 10 with a threaded pin M5 x 25 and tighten to stop.



Adjust transporter height with deactivated stroke movement so that the upper edge of the transporter is at the height of the upper edge of the needle plate. Adjust the transporter height once again with the stroke movement activated, as described in chapter 1.05.06.

1.05.06 Height of the bottom feed dog

Requirement

1. When the needle bar is positioned at b.d.c. (balance wheel position 180°), the bottom feed dog should be positioned **0.5 mm** horizontally above the top edge of the needle plate, when crank **5** is in the centre of the slot.
2. In the direction of sewing, the bottom feed dog should be positioned in the centre of the needle plate slot.

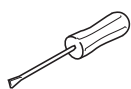
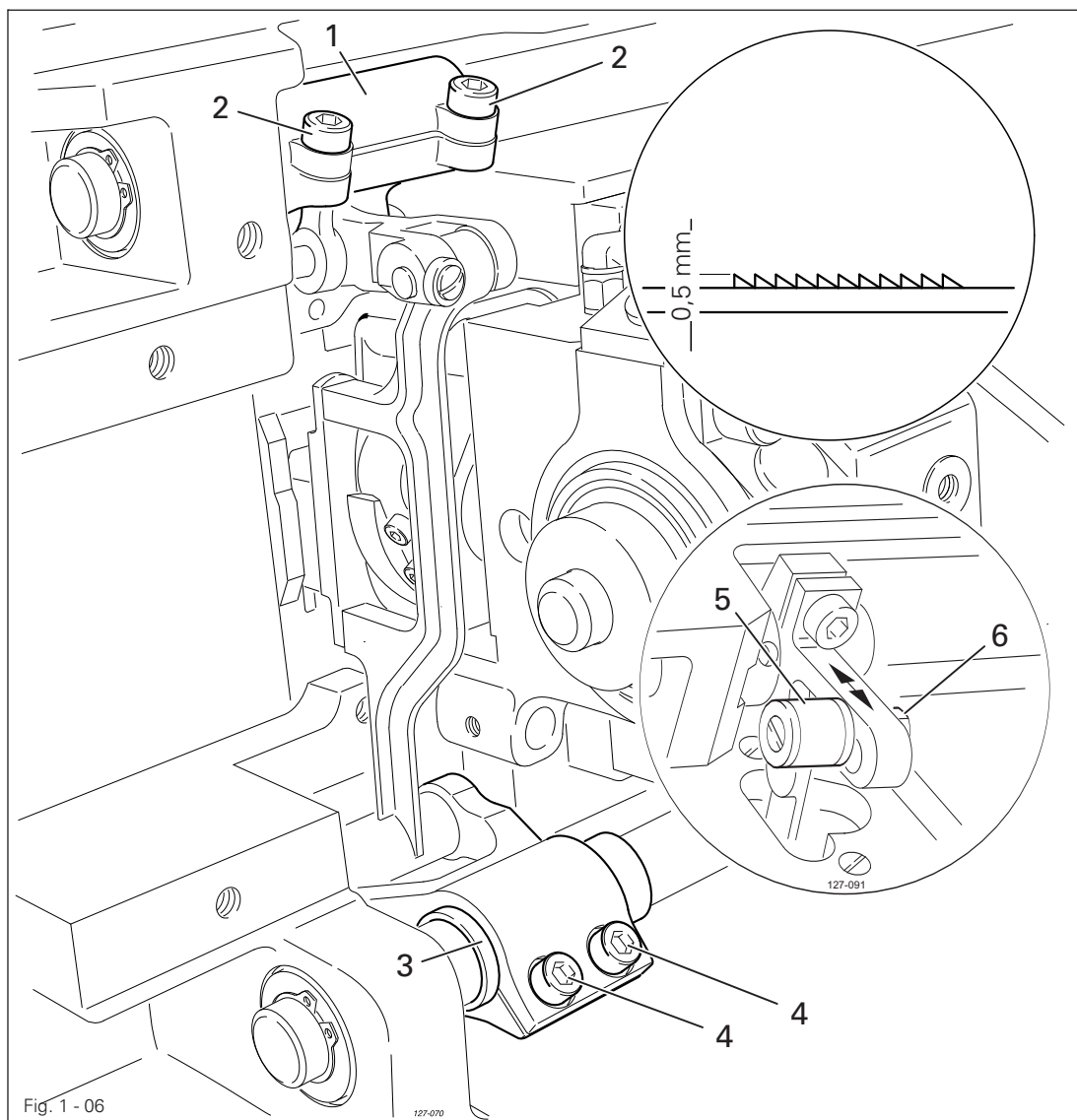

- Turn lifting crank **1** (screws **2**) and eccentric sleeve **3** (screws **4**) according to **Requirement 1**, and set feed dog in centre of needle-plate slot as shown in **Requirement 2**.



The height of the bottom feed dog can also be increased or reduced as required by moving crank **5** (nut **6**) up or down.

1.05.07 Feeding stroke difference

Requirement

With the maximum stitch length set, when the balance wheel is turned the feeding strokes of the needle and the bottom feed dog should be the same.

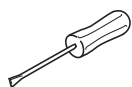
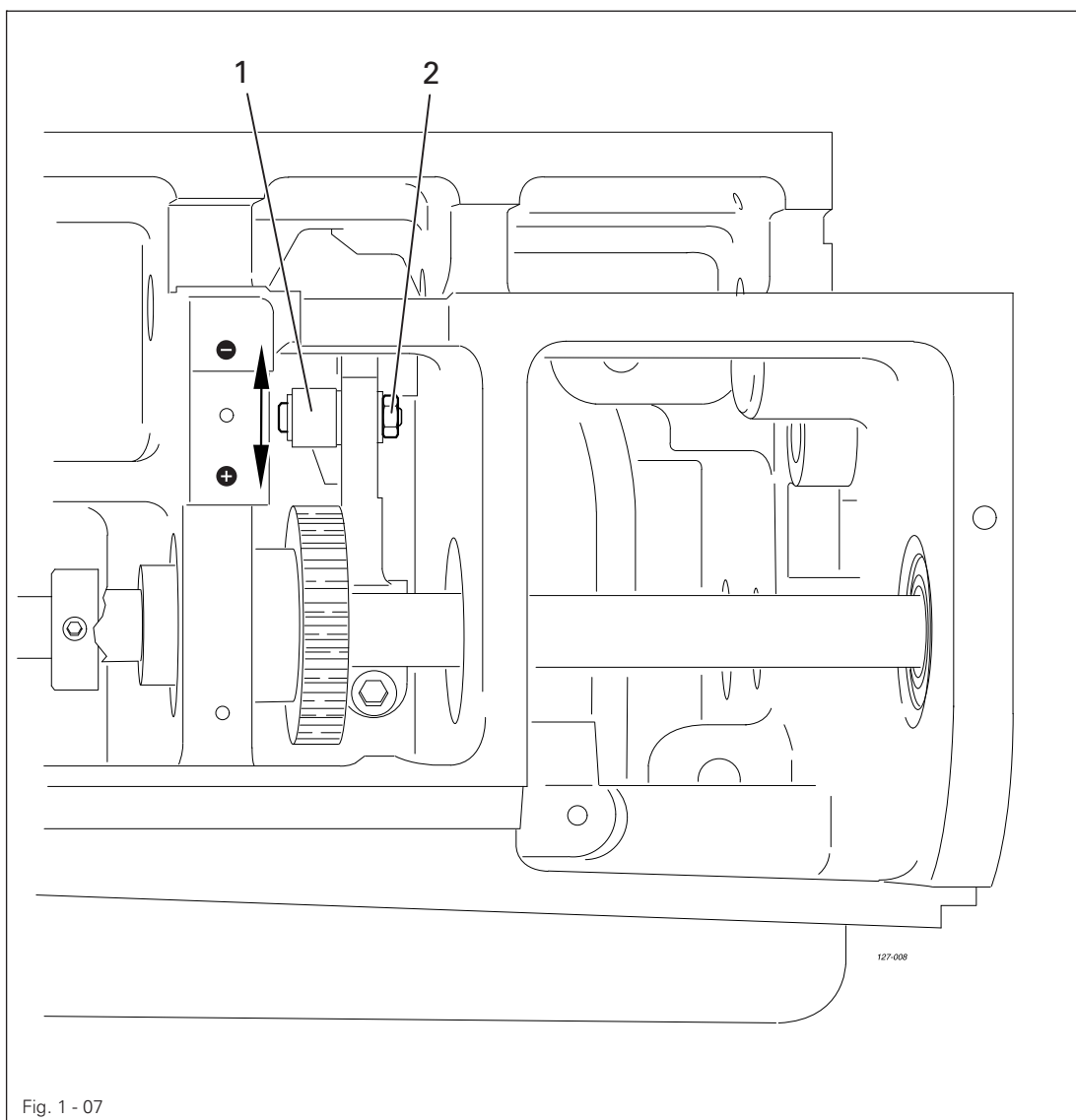

- With connecting rod 1 (nut 2) increase ("+") or reduce (-) the needle feed stroke in accordance with the **requirement**.

1.05.08 Preliminary adjustment of the needle height

Requirement

When the needle bar is positioned at t.d.c. (balance wheel position 0°), the clearance between the needle point and the needle plate should be **22 mm**.

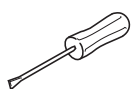
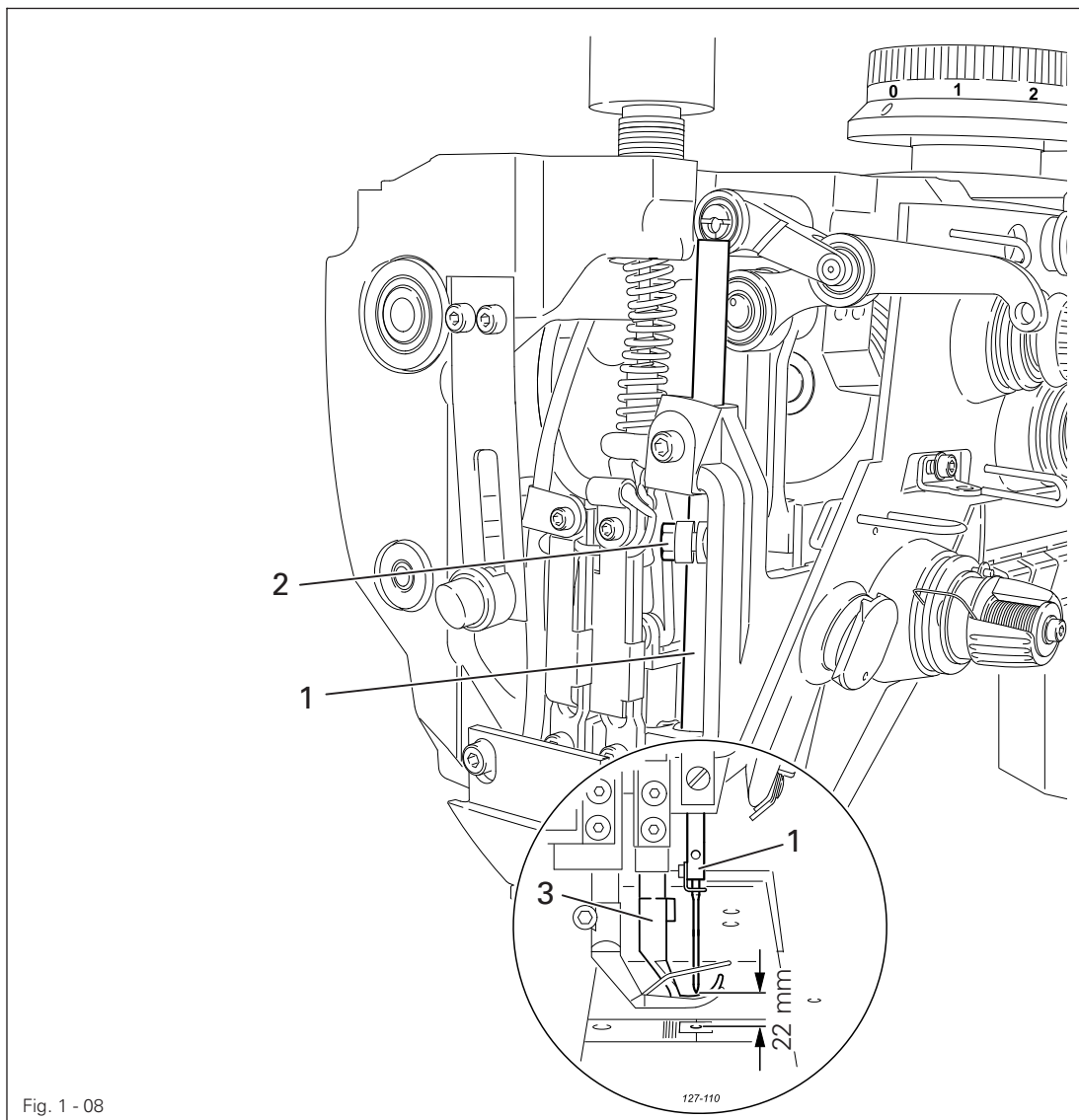

- Without turning it, re-position needle bar 1 (screw 2) in accordance with the requirement.



Make sure that needle bar 1 and foot 3 do not collide.

1.05.09 Needle rise, hook clearance, needle height and needle guard

Requirement

With the stitch length set at "4.5" and in the needle rise position (see table)

1. The hook point **6** should be positioned at "needle centre" with a hook-to-needle clearance of **0.05 – 0.10 mm**.
2. The top of the needle eye should be positioned **0.8 mm** below hook point **6**.
3. and needle guard **7** must touch the needle just lightly.

**Needle rise position**

Model C: Balance wheel position **203° / 2.0 mm**

Model D: Balance wheel position **206° / 2.4 mm**

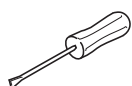
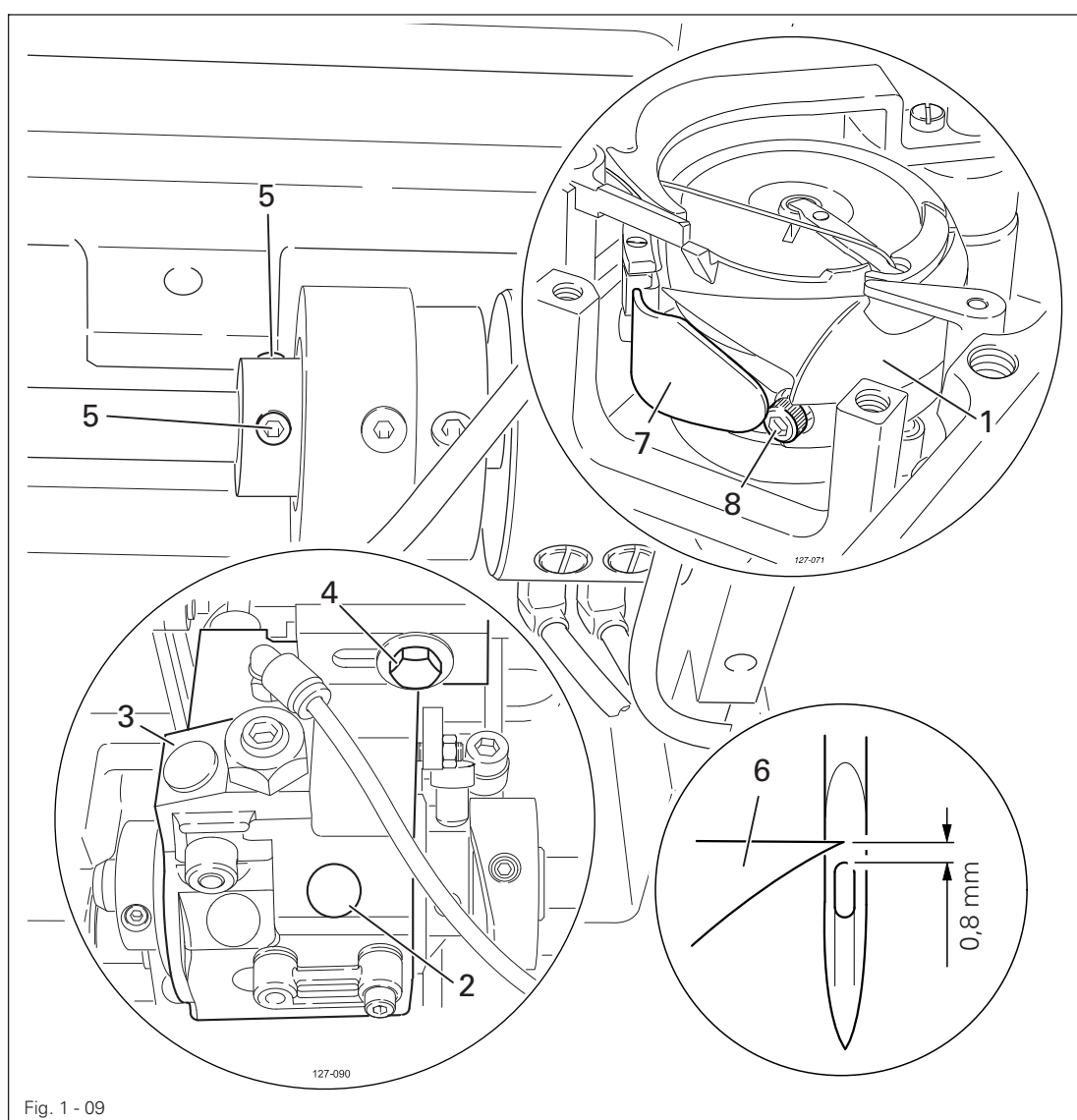

- Loosen both screws of the gear drive of hook **1** (under cover **2**).
- Adjust hook **1** and hook bearing **3** (screws **4** and **5**) in accordance with **requirement 1**.
- Without turning it, re-position the needle bar in accordance with the **requirement 2**, also see Chapter 1.05.08 **Preliminary adjustment of the needle bar**.

Adjustment

- Adjust needle guard **7** (screw **8**) in accordance with **requirement 3**.



If the needle size is changed, a quick adjustment of hook bearing **3** is possible, after loosening screws **4** and **5**.

1.05.10 Top feed stroke

Requirement

With adjustment wheel 1 set at "7", the top feed dog 7 and presser foot 4 should each rise by 7.0 mm.

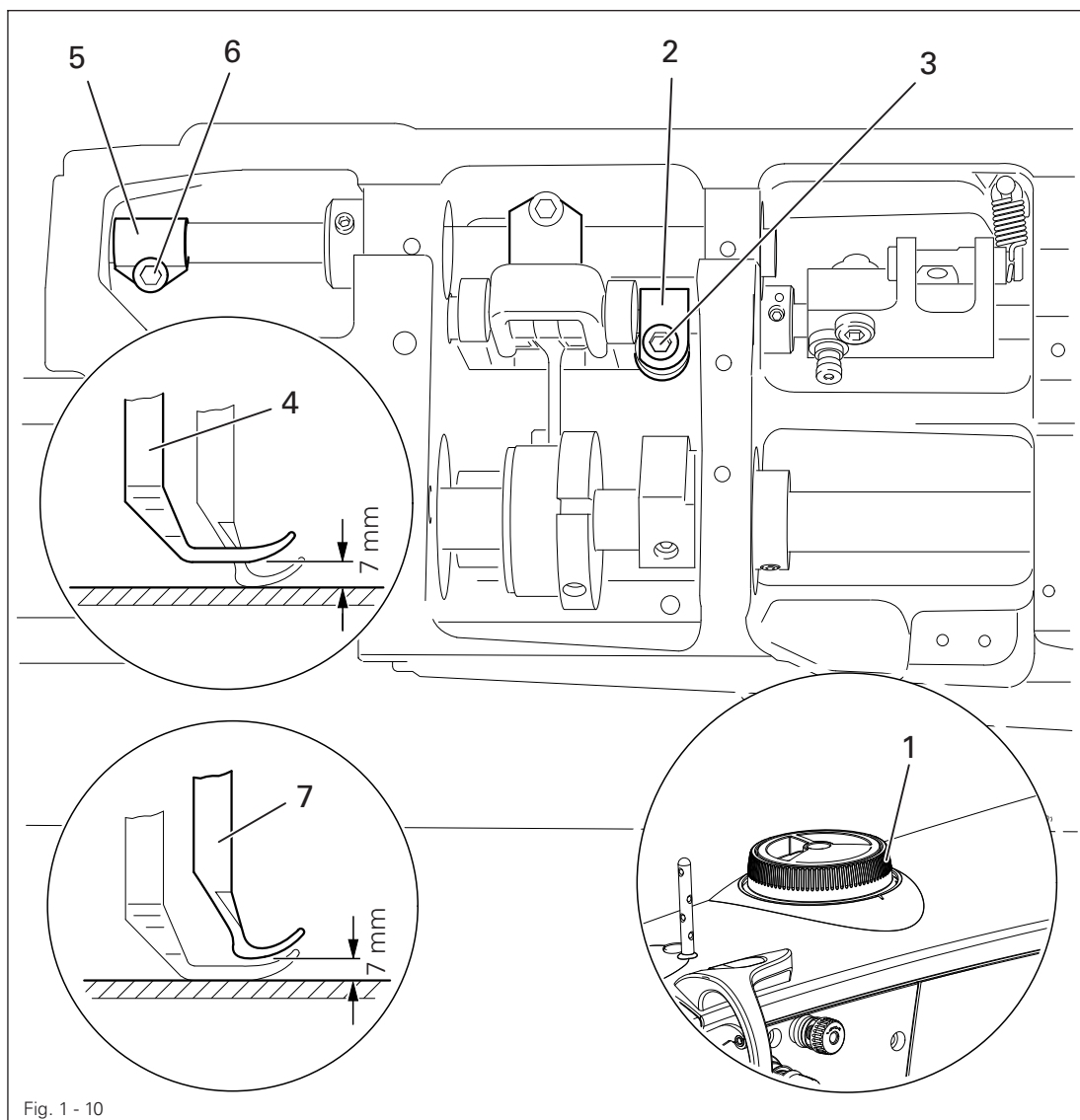
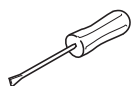

Fig. 1 - 10



- Remove the bottom feed dog and set adjustment wheel 1 at "7".
- Loosen the screws of the needle plate, place the metal gauge over the opening of the needle plate slot so that both sewing feet can be lowered onto the metal gauge.
- For the preliminary adjustment, adjust crank 2 (screw 3) so that there is a clearance of 7 mm between presser foot 4 and the needle plate.
- Adjust crank 5 (screw 6) so that top feed dog 7 and presser foot 4 have the same stroke.
- Check the adjustment in accordance with the **requirement**, and correct if necessary.

1.05.11 Top-feed lifting motion

Requirement

The top feed dog should just have reached the needle plate when the presser foot lift is set at **5 mm** and the needle descending from above is **2 mm** above the needle plate.

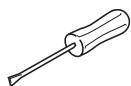
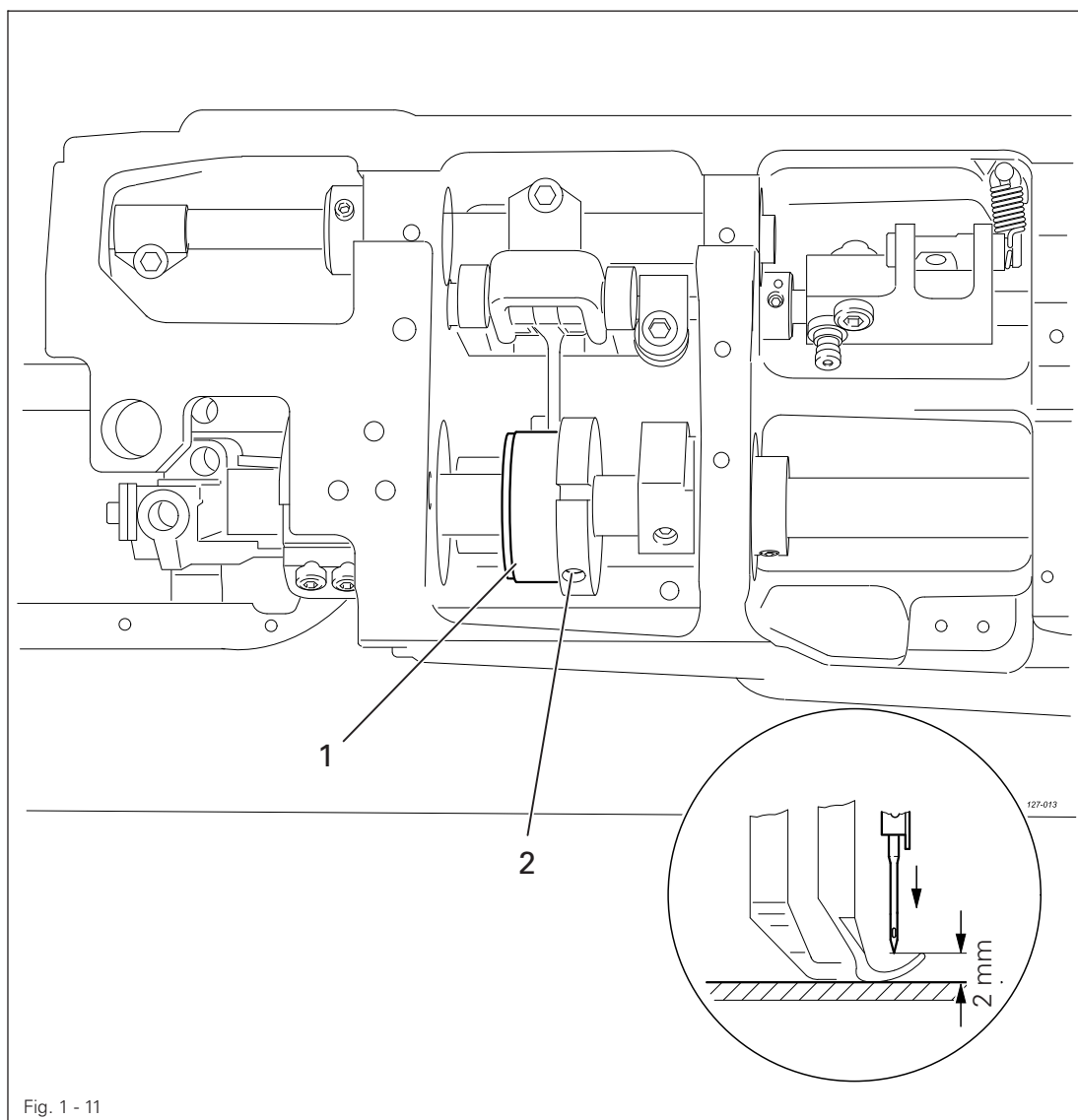

- Turn eccentric 1 (screw 2) in accordance with the **requirement**.

1.05.12 Adjusting the potentiometer for speed reduction

1.05.12 .01 Machines with P74 ED-L

- Switch on the machine
- Set the smallest stroke "0".
- Using the stroke adjustment function, call up the smallest stroke (LED off), see the Control Panel Instruction Manual.
- Call up parameter "501" and press key "C+" to save the bottom value.
- Set the inner adjustment wheel at maximum stroke "9".
- Using the stroke adjustment function, call up the largest stroke (LED on), see the Control Panel Instruction Manual.
- Call up parameter "502" and press key "C+" to save the top value.



The speed is adjusted in accordance with Chapter **3.03 Maximum Speed in the Instruction Manual**.

1.05.12.02 Machines with PF 321

- Press "P" on the control panel, while simultaneously switching the machine on.
- Enter the code **3112** via the numbered keys and confirm by pressing "E".
- Select parameter **501** via the numbered keys and confirm by pressing "E".
- Set the smallest stroke "0".
- Using the stroke adjustment function, call up the small stroke (LED off), see instruction manual.
- Take over the value displayed under parameter **501** by pressing "+".
- Select parameter **502** via the numbered keys.
- Set the largest stroke "0".
- Using the stroke adjustment function, call up the large stroke (LED on).
- Take over the value displayed under parameter **502** by pressing "+".
- Press "P" twice to quit the input level
- The new values are taken over when sewing is started, and these are maintained even after the machine is switched off.



The speed is adjusted in accordance with Chapter **3.03 Maximum Speed in the instruction manual**.

Under parameter **117** the speed at max. stroke adjustment can be reduced again.

1.05.13 Bobbin case opener stroke

Requirement

When the balance wheel is turned

1. The beak **4**, when it is at the right point of reversal of the bobbin case opener **1**, should rise from the needle plate **5** by the thickness of the thread.
2. The bobbin case opener **1** should be at its left point of reversal when the balance wheel is positioned at "10°".

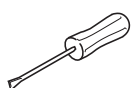
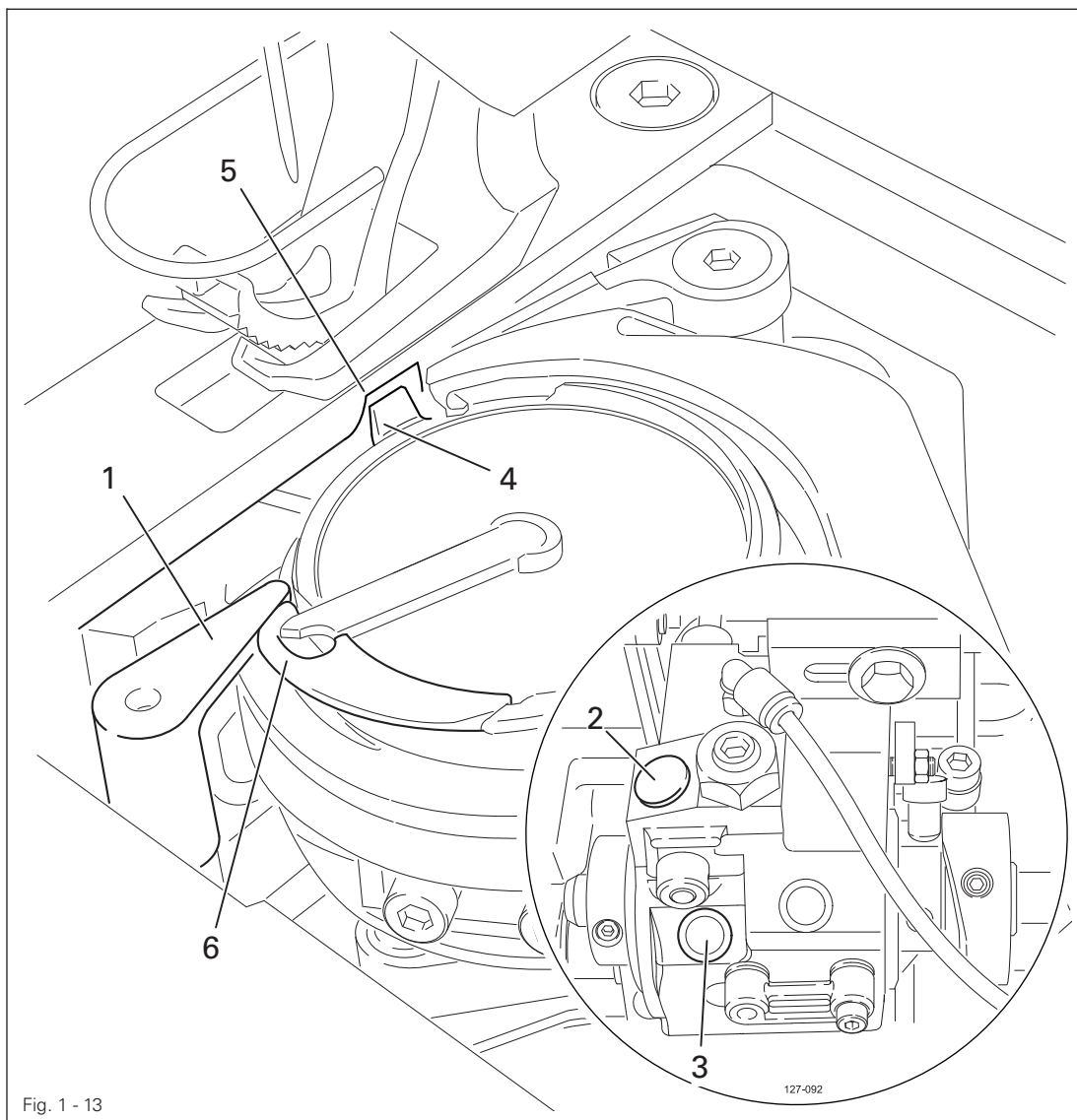

- Adjust bobbin case opener **1** (screw under cover **2**) in accordance with **requirement 1**.
- Adjust the eccentric (screw under cover **3**) in accordance with **requirement 2**.



The thread must be able to pass unhindered between bobbin case opener **1** and bobbin case **6**.

1.05.14 Adjusting the shortened trim stitch

Requirement

For the trim stitch the machine should carry out a stitch length of 0.5 – 1.0 mm.

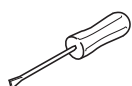
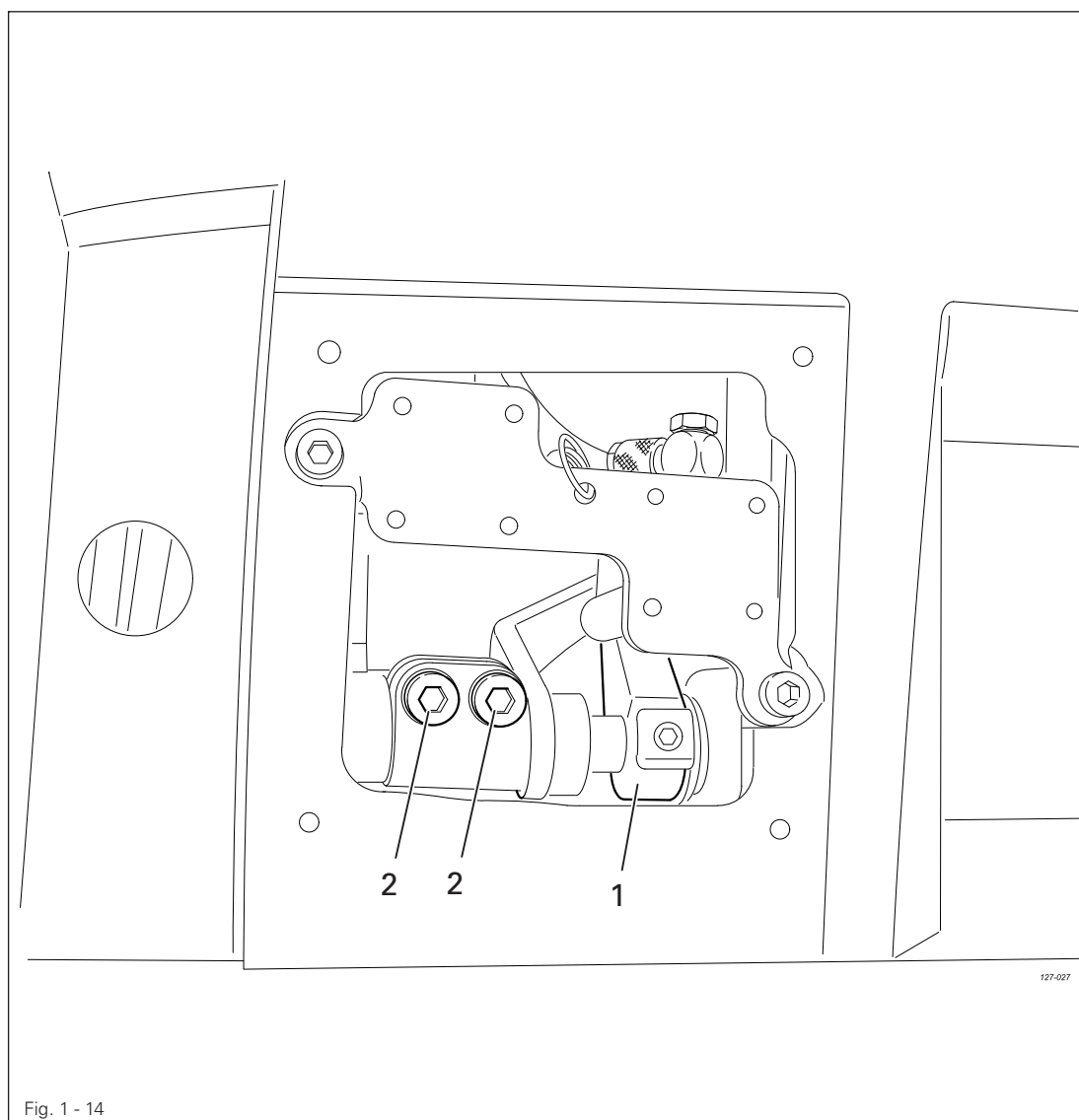

- Adjust lever 1 (screws 2) in accordance with the requirement.

1.05.15 Bobbin winder

Requirement

1. When the bobbin winder is engaged, the winding spindle must be driven reliably.
When it is disengaged, friction wheel **3** should not be touching drive wheel **1**.
2. When it is switched off, the bobbin winder must click securely into its end position (knife raised).

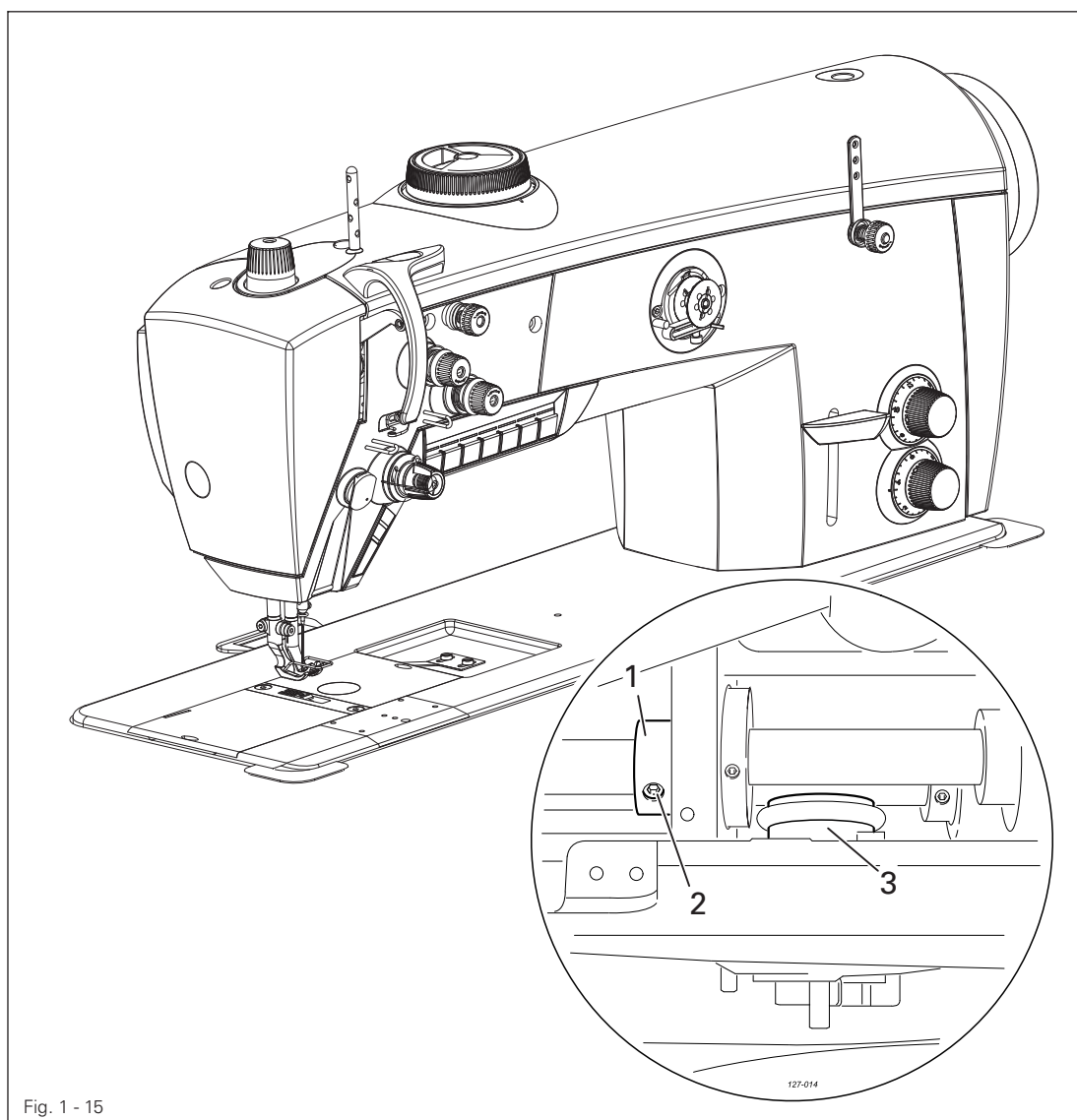
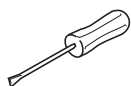

Fig. 1 - 15



- Adjust drive wheel **1** (screw **2**) in accordance with the **requirement**.

1.05.16 Thread check spring and thread regulator

Requirement

1. The movement of thread regulator **3** must be completed when the needle point enters the material.
2. When the thread loop is at its largest while being passed around the hook, the check thread spring **3** should rise slightly from the rest **1**.

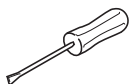
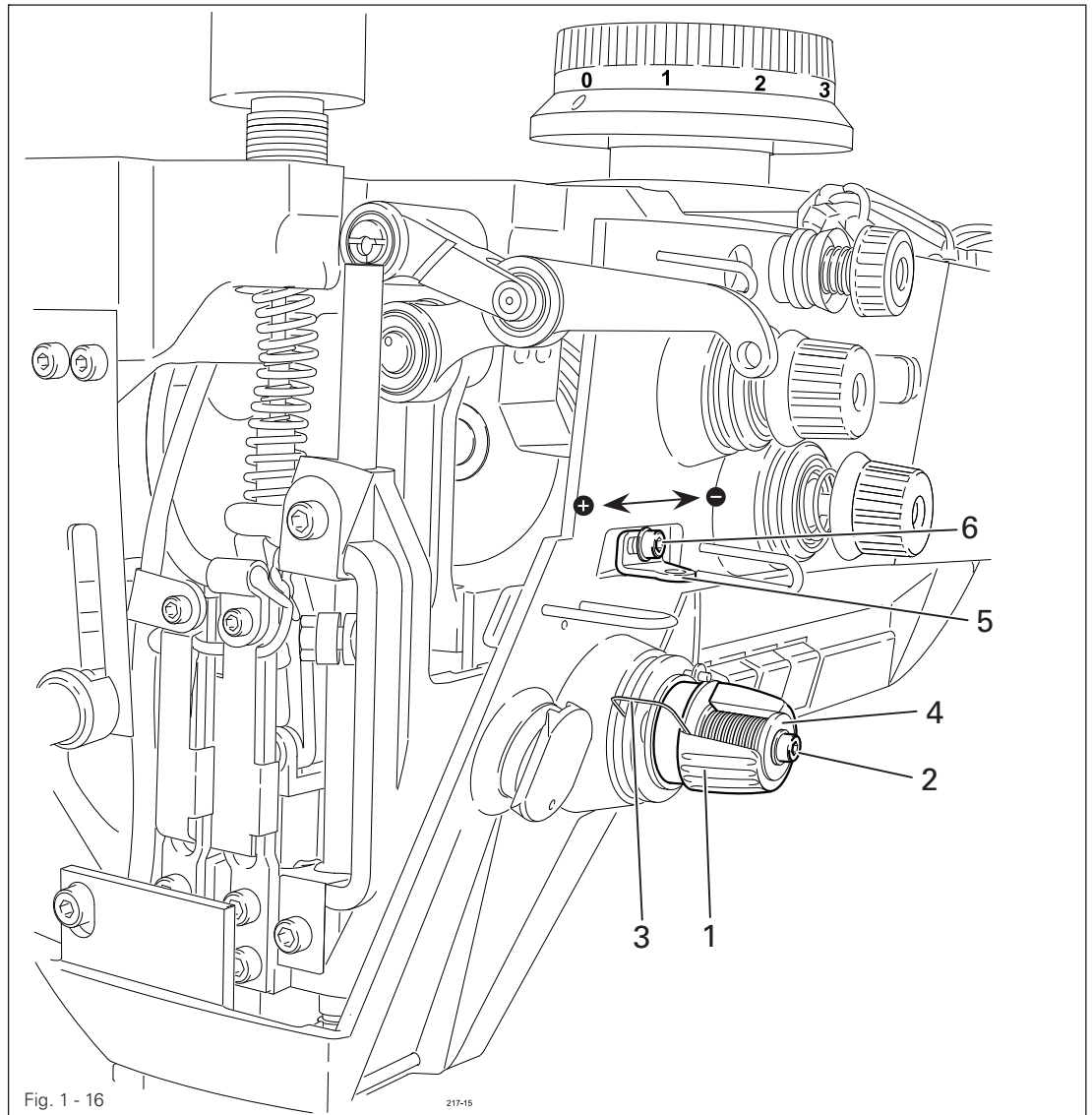

- Position rest **1** (screw **2**) in accordance with **requirement 1**.
- Turn sleeve **4** (screw **2**) to adjust the tension of thread check spring **3**.
- Position thread regulator **5** (screw **6**) in accordance with **requirement 2**.



For technical reasons it may be necessary to deviate from the indicated spring stroke or spring tension.

Move thread regulator **5** (screw **6**) towards ("**+**") (= more thread) or ("**-**") (= less thread).

Adjustment

1.05.17 Sewing foot pressure

Requirement

The material should be fed properly even at maximum speed and with the smallest stroke.

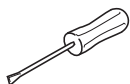
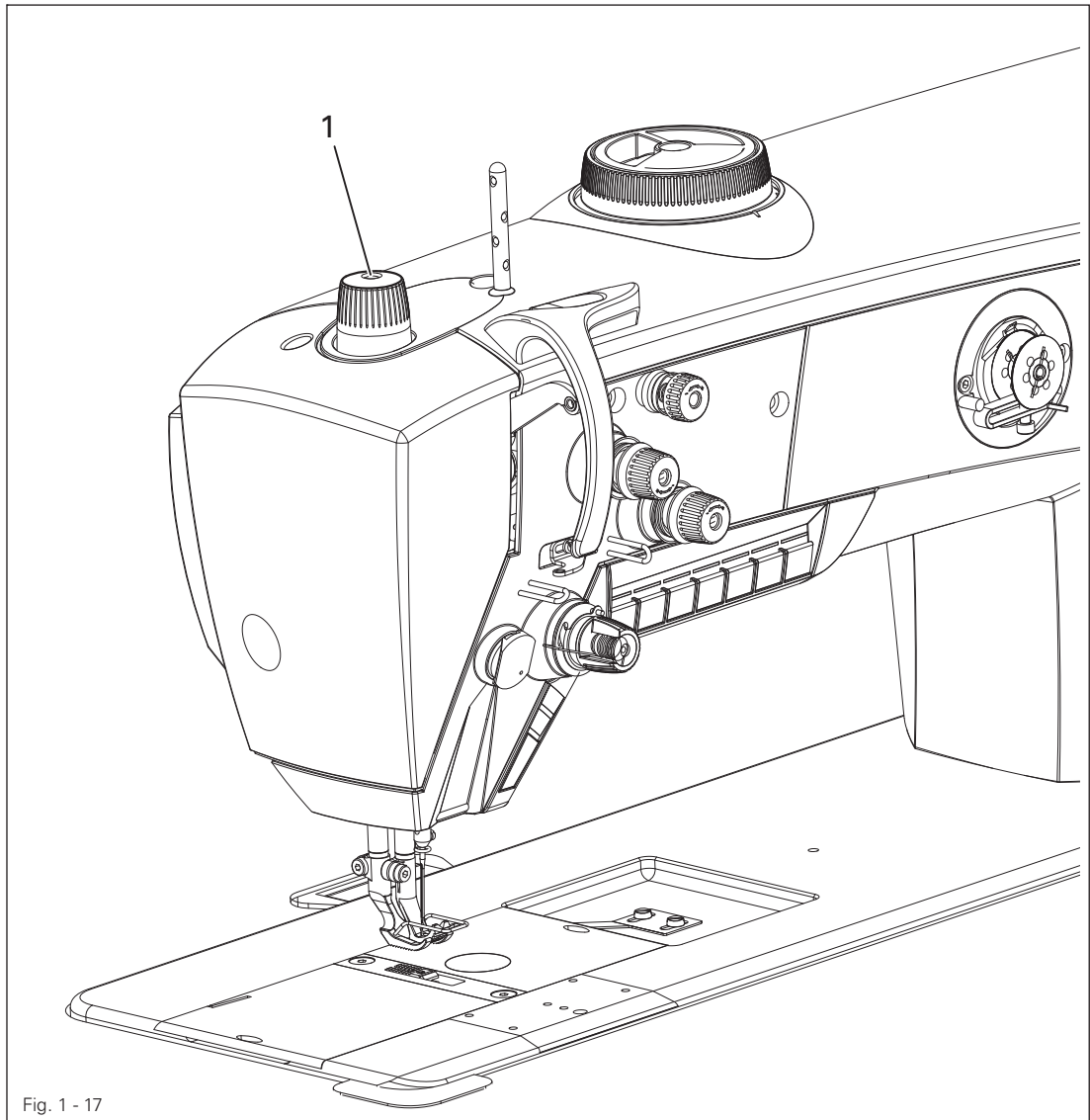

- Turn adjustment wheel 1 in accordance with the **requirement**.

1.05.18 Lubrication

Requirement

After a running time of **10** seconds a thin film of oil should be visible on paper strip **1** when this is held over the hook.

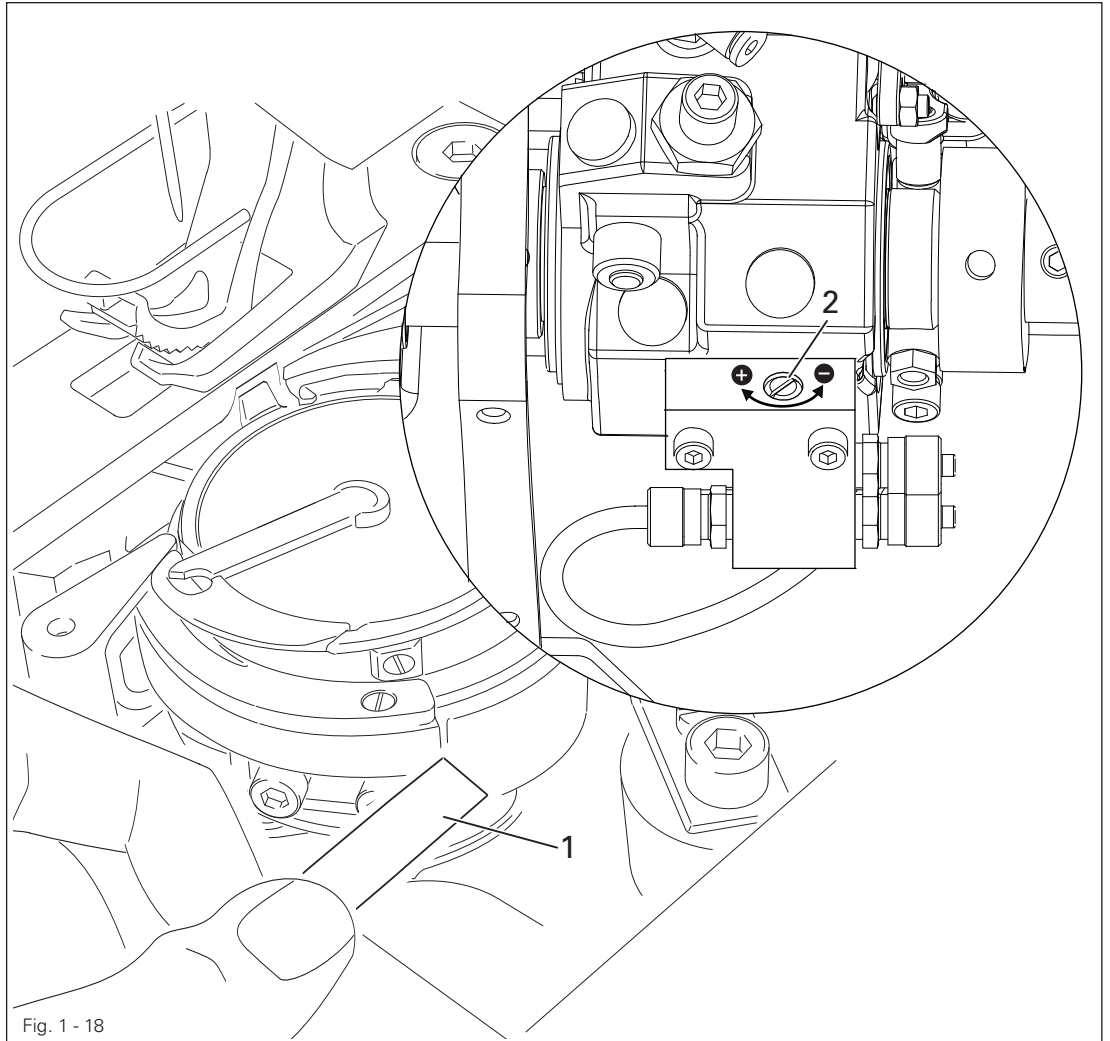
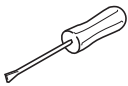

Fig. 1 - 18



- Check that the machine is filled with oil and that the oil lines are free of air.
- Run the machine for 2 – 3 min.



Do not put your hands into the needle area when the machine is running!
Danger of injury from moving parts!

- With the machine running, hold paper strip **1** against the hook and check the **requirement**.
- If necessary, regulate amount of oil with screw **2**.

1.05.19 Limiting the stitch length



When exchanging the parts kit with stitch lengths differing from the as-delivered state of the machine, limit the max. stitch length using stitch adjuster 4.

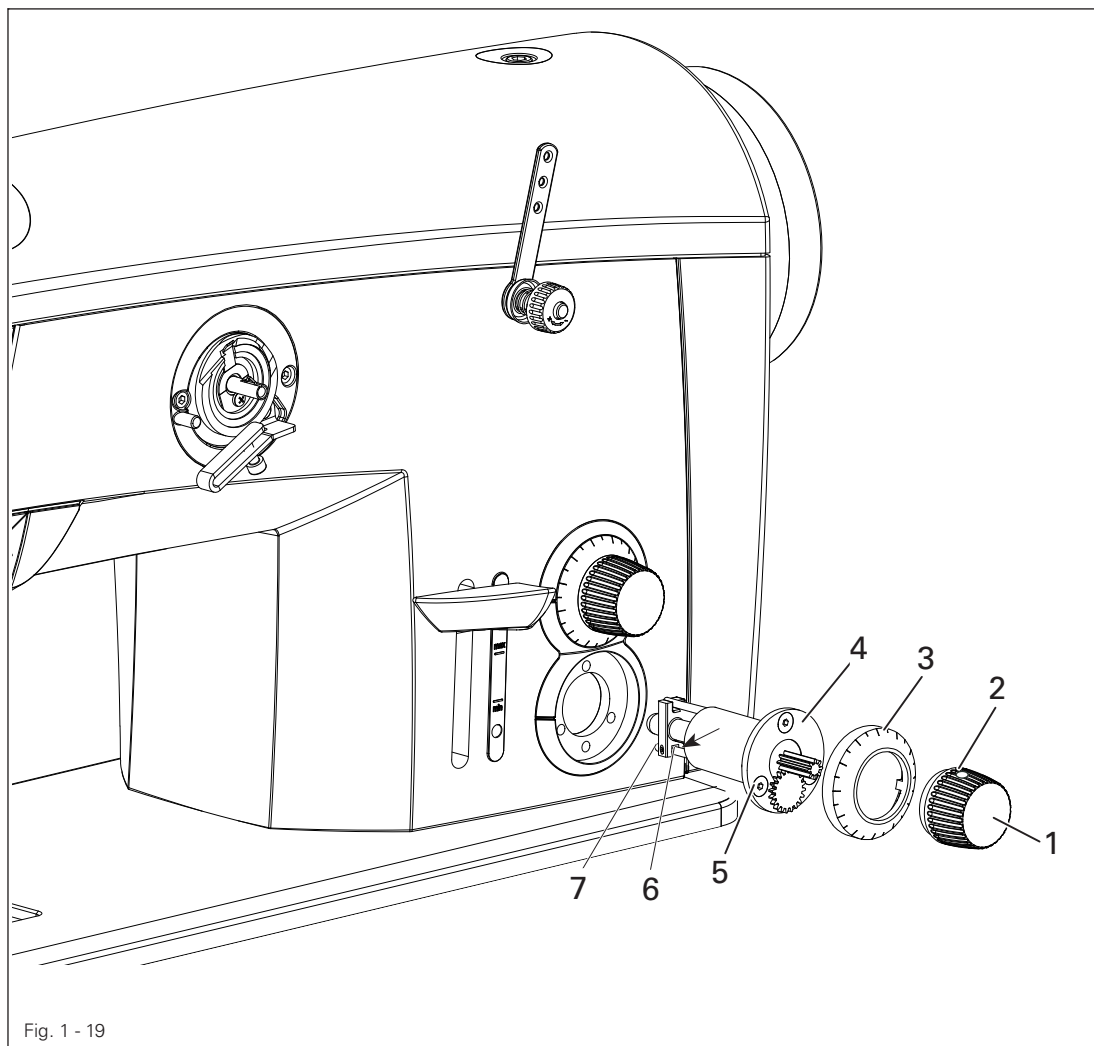
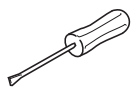

Fig. 1 - 19



- Set the desired max. stitch length at control button 1 (on model CN9 = 9.0 mm, on model DN12 = 12 mm)
- Remove adjustment knob 1 (screws 2) and scale dial 3.
- Remove adjustment unit 4 (screws 5).
- Bring lineal 6 (screw 7) to the unit using stitch adjuster 4 (see arrow).
- Replace adjustment unit 4, scale dial 3 and adjustment knob 1.

1.05.20 Speed reduction

Requirement

If a stitch length longer than 9 mm is set, the speed reduction switch 3 must be pressed.

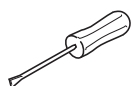
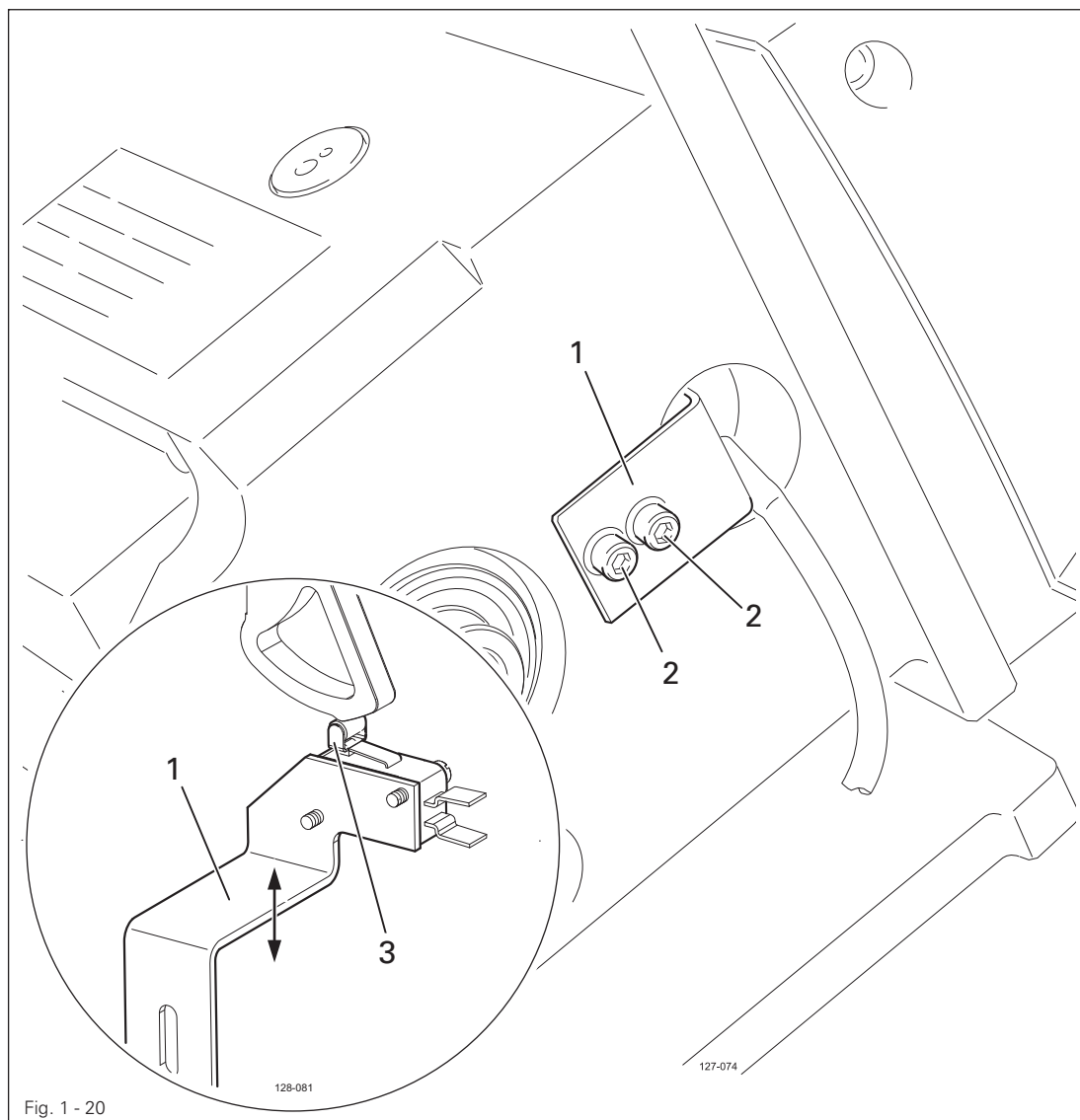

- Adjust retaining plate 1 (screws 2) in accordance with the requirement.

1.05.21 Re-engaging the slip-clutch



Clutch 1 is adjusted at the works. In the case of a thread jamming, clutch 1 will disengage, in order to avoid damage to the hooks.

The following describes how to re-engage clutch 1.

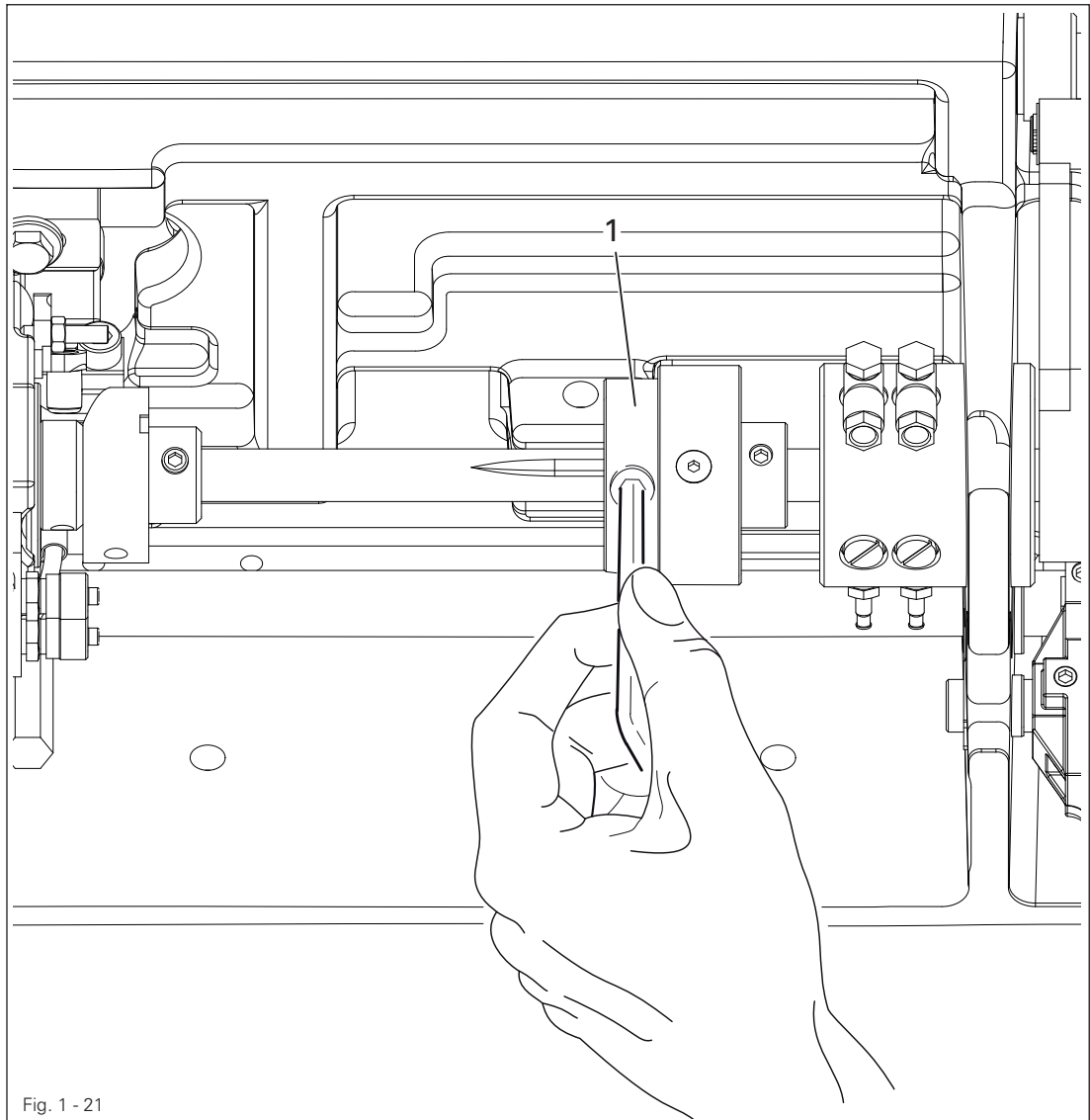

Fig. 1 - 21

- Remedy jammed thread fault.
- Hold clutch 1 firmly, as shown in Fig. 13-22, and turn the balance wheel until clutch 1 re-engages.

1.06 Adjusting the thread trimmer -900/81

1.06.01 Resting position of roller lever/radial position of control cam

Requirement

1. When the take-up lever is at t.d.c. (balance wheel position 60°), control cam **1** should just have moved roller lever **5** into its basic position.
2. When the thread trimmer is in its resting position, there should be a clearance of **0.1 mm** between roller lever **5** and control cam **1**.

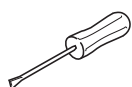
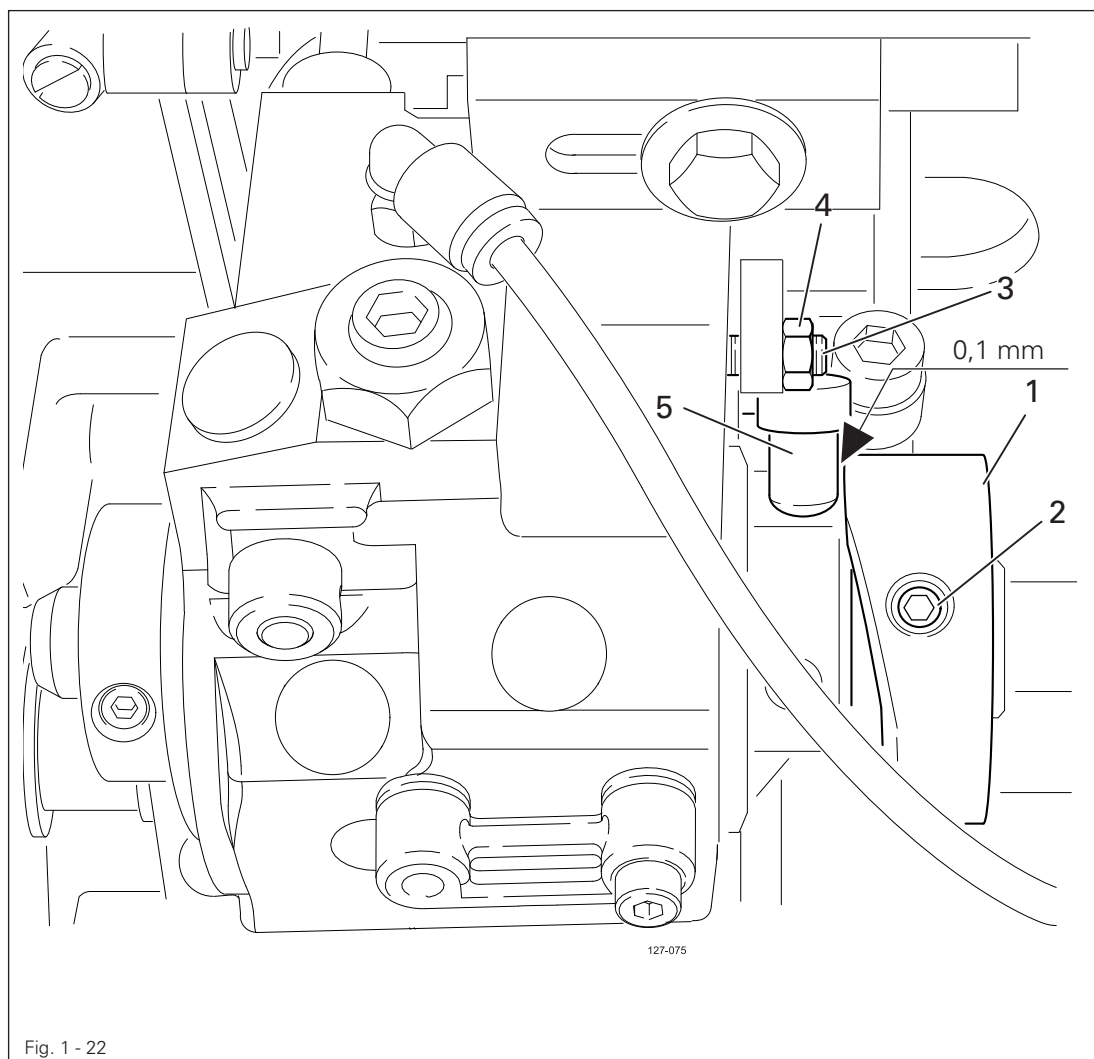

- Adjust control cam **1** (screws **2**) in accordance with requirement 1.
- Adjust screw **3** (nut **4**) in accordance with requirement 2.

1.06.02 Position and height of the thread catcher

Requirement

When the needle bar is positioned at b.d.c. (balance wheel position 180°) the edges of thread catcher 3 and knife 5 should be flush (see arrow).

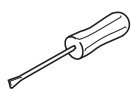
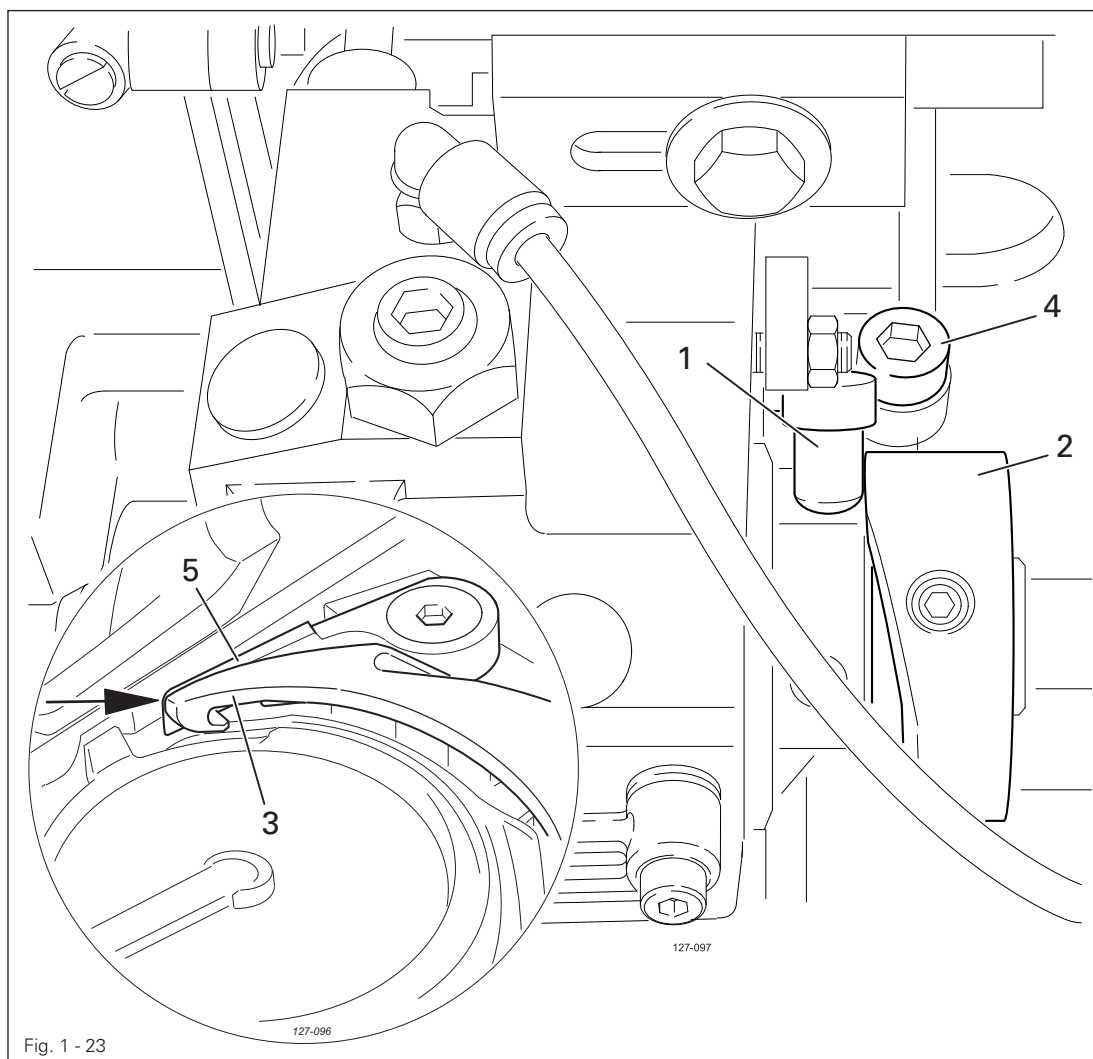

- Press roller lever 1 against control cam 2.
- Adjust thread catcher 3 (screw 4) in accordance with the requirement



The height of thread catcher 3 is pre-set by the manufacturer and, if necessary, it can be adjusted with washers under thread catcher 3 on the base of the hook bearing.

1.06.03 Knife pressure

Requirement

When the front edge of thread catcher 3 is 5 – 6 mm in front of the knife blade, the knife 4 should be touching the catcher edge with slight pressure.

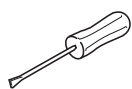
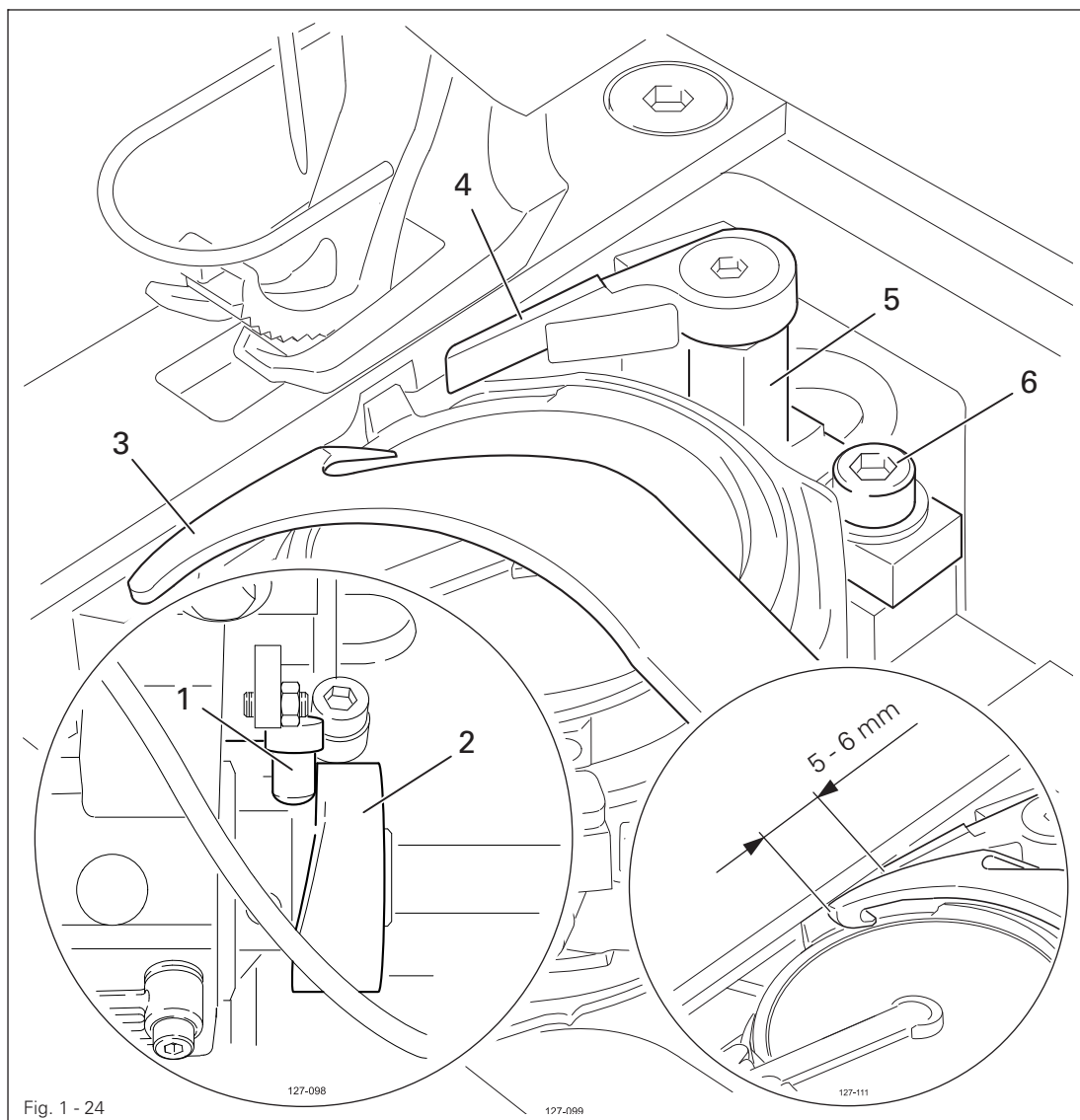

- Bring the take-up lever to its b.d.c and press roller lever 1 into the control cam 2.
- Turn the balance wheel until the front edge of catcher 3 is at a distance of 5 – 6 mm from the blade of knife 4.
- Swing knife bearing 5 (screw 6) in accordance with the requirement.



After completing the adjustment, recheck the position of the thread catcher in accordance with Chapter 1.06.02 Position and height of the thread catcher.

Adjustment

1.06.04 Bobbin thread clamp spring

Requirement

When the thread trimmer is in its cutting position, the clamp spring should slightly touch the thread catcher and hold the thread reliably.

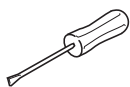
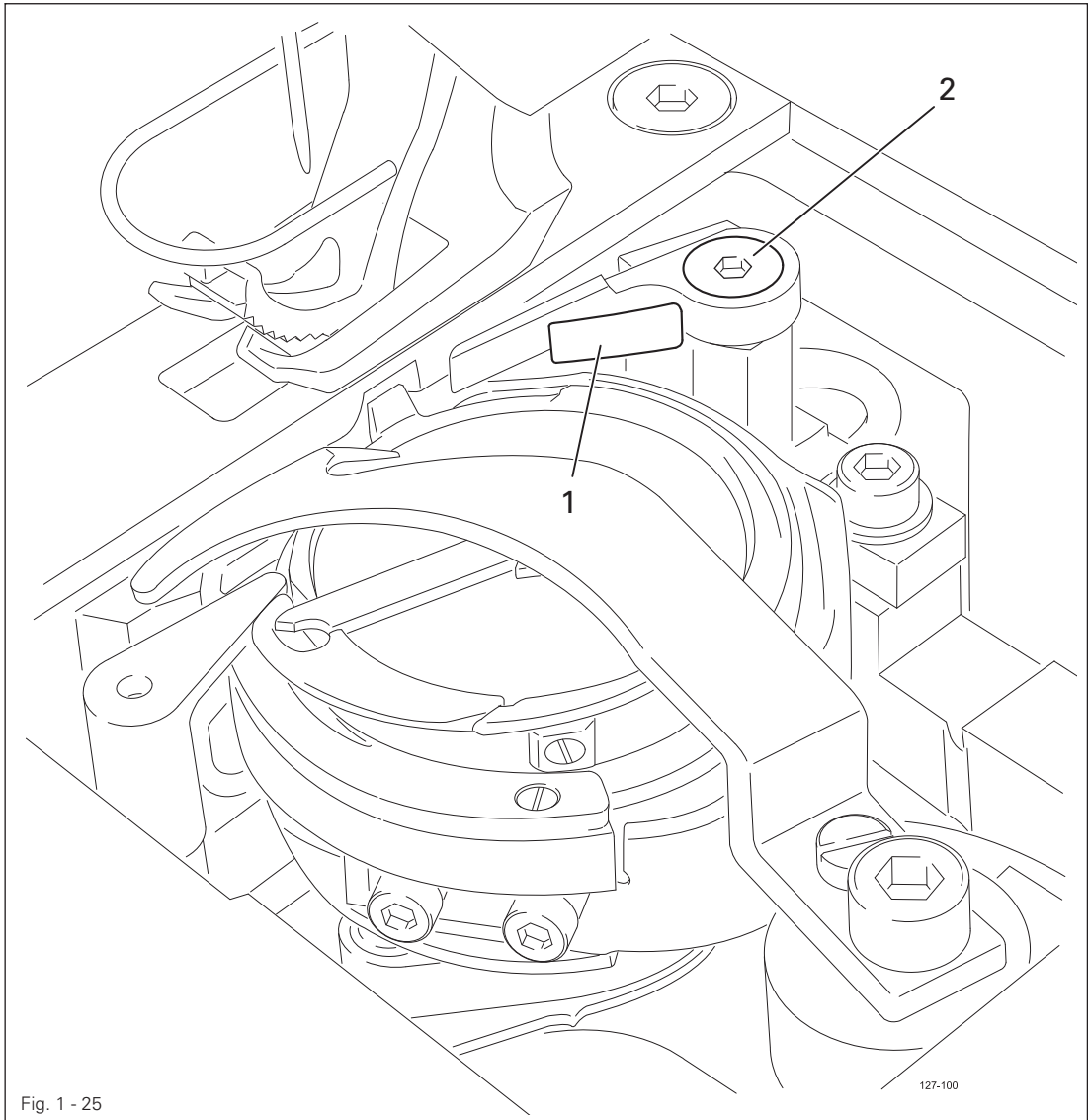

- Adjust clamp spring 1 (screw 2) in accordance with the **requirement**.
- Carry out the cutting operation by hand and check the setting. Readjust if necessary.

1.06.05 Manual cutting test

Requirement

1. 1. When moving forward, thread catcher **1** must not move bobbin thread **3**
2. When thread catcher **1** is at its front point of reversal, bobbin thread **3** should be in the centre of the marked area (see arrow).
3. After the cutting operation has been completed, needle and bobbin thread should be cut neatly and bobbin thread **3** held.

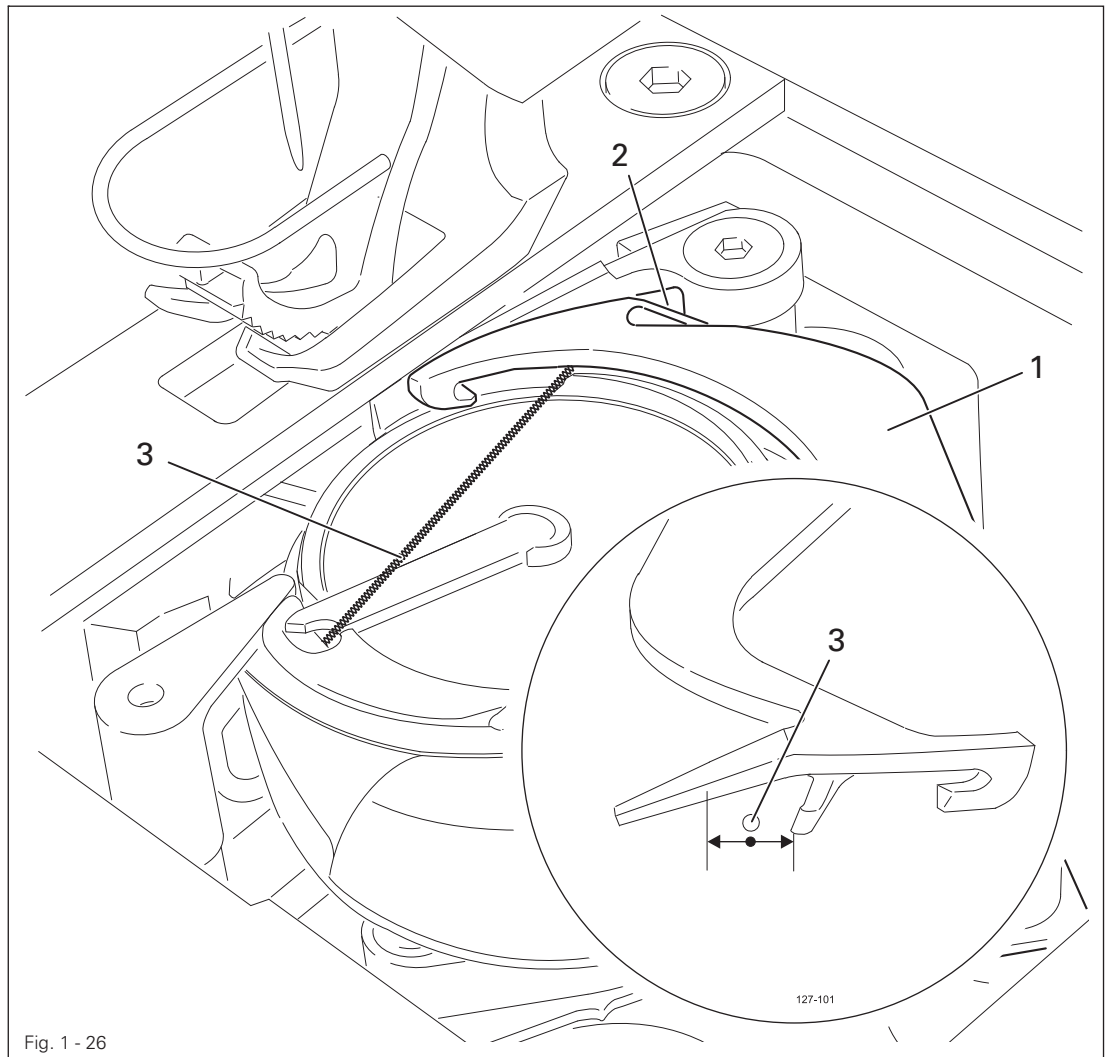
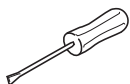

Fig. 1 - 26



- Sew a few stitches.
- Switch off the main switch and the compressed air.
- Carry out a manual cutting test.
- Check **requirement 1**. If necessary, readjust thread catcher **1** in accordance with Chapter **1.06.02 Position and height of the thread catcher**.
- Check **requirement 3**. If necessary, readjust bobbin thread clamp spring **2** in accordance with Chapter **1.06.04 Bobbin thread clamp spring**.



Consult the instruction manual for the drive for a description of the parameter settings and a list of the parameters.

1.07 Adjusting the thread trimmer device -900/82

1.07.01 Preliminary testing

1.07.02 Assembly of the thread clamp carrier and thread catcher

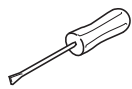
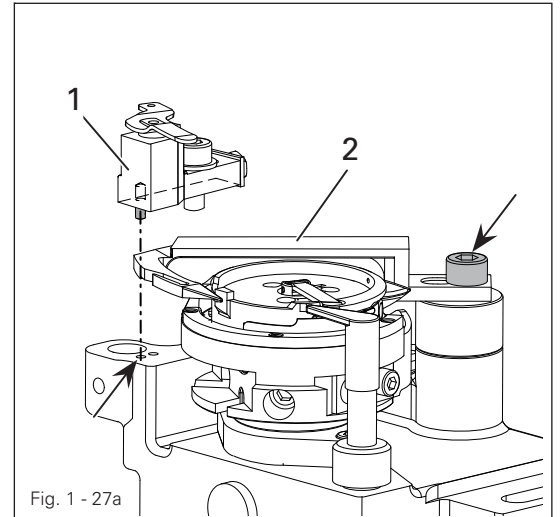
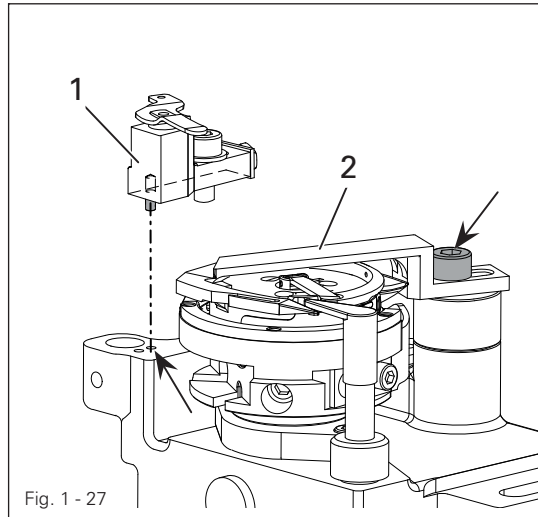

- Assemble thread clamp carrier 1 and thread catcher 2 depending on the hock size:
 - Large hock assembly (bobbin diameter 26 mm) is shown in Fig. 1 - 27.
 - Extra large hock assembly (bobbin diameter 32 mm) is shown in Fig. 1 - 27a.

1.07.03 Check settings according to the following chapter:

- Check the home position of the handwheel.
- Check lower, upper and needle feed sliding movement.
- Check bottom transporter lifting movement..

1.07.04 Needle position in sewing direction

Rule

At stitch length setting "0", the needle in sewing direction should pierce the middle of the setting gauge hole 1.

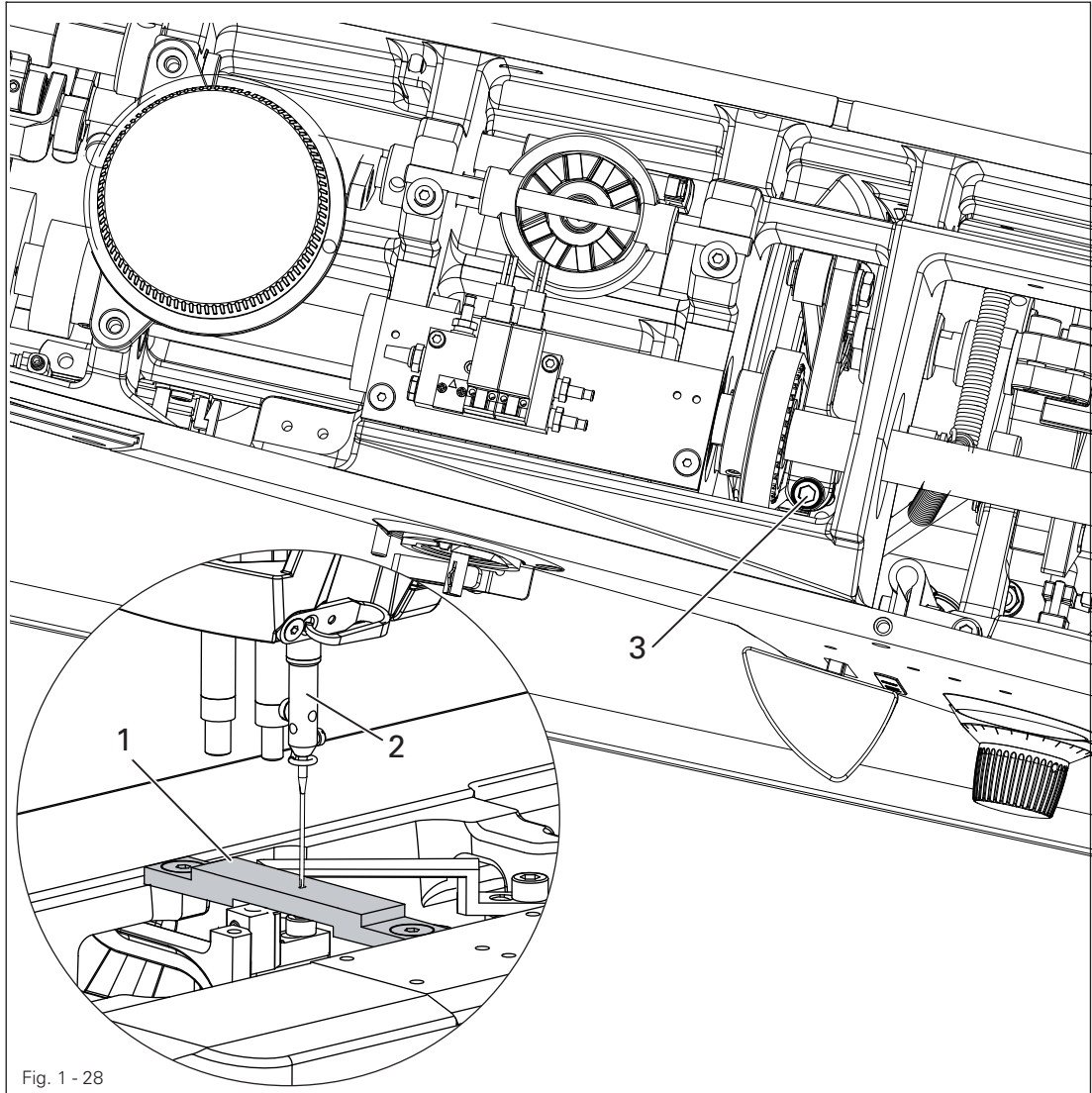
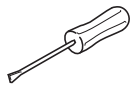

Fig. 1 - 28



- Unscrew the needle plate and bottom transporter..
- Insert a 100/100 mm thick needle.
- Unscrew setting gauge 1 (Order No. 61-111 689-07).
- Adjust needle bar 2 (screw 3) in accordance with the rule.
- Unscrew the setting gauge again.
- Reassemble the bottom transporter.

1.07.05 Bottom transporter in sewing direction

Rule

At stitch length setting "0", the needle in sewing direction should pierce the middle of the stitch hole in the bottom feed 1.

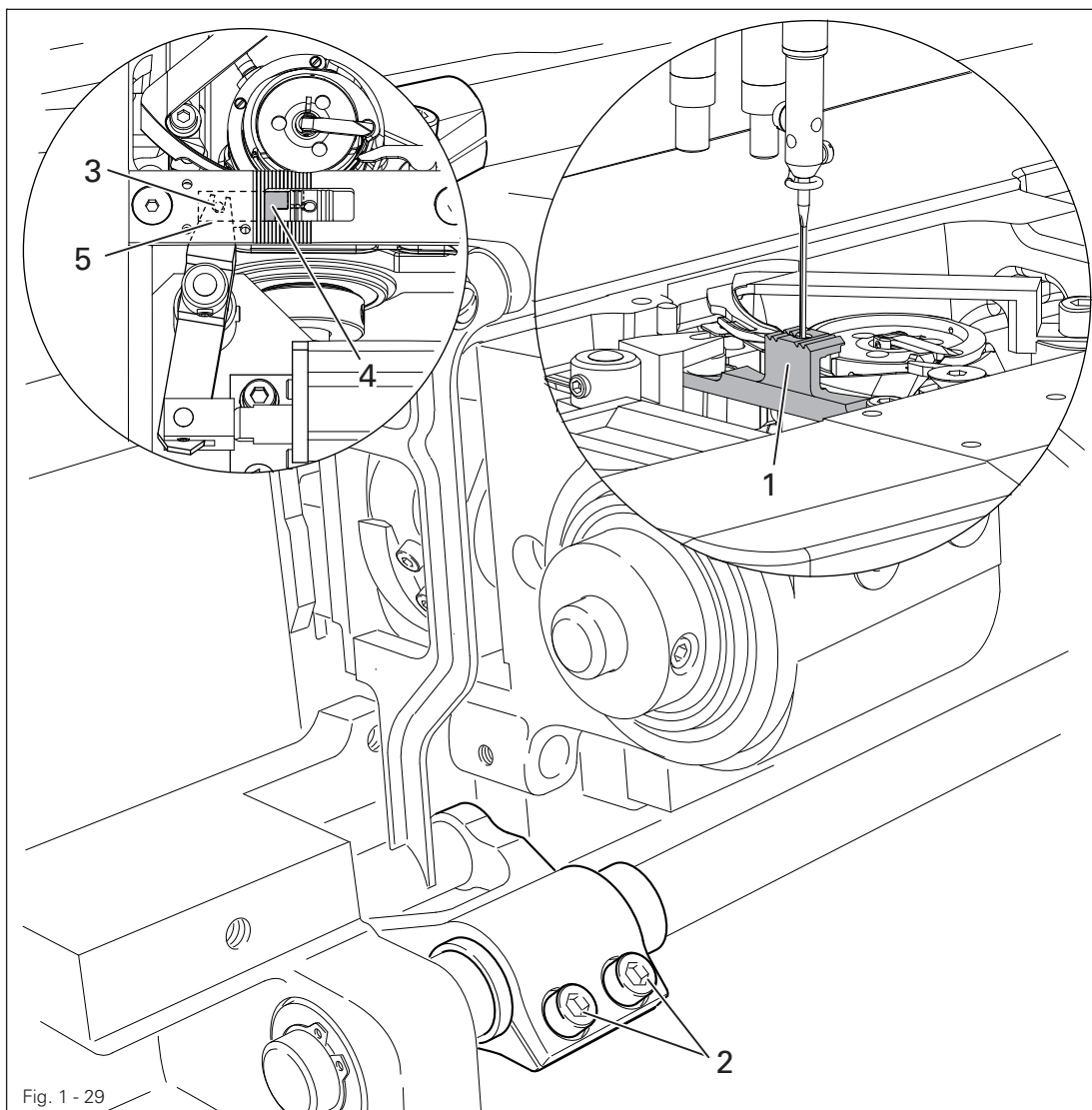
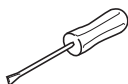

Fig. 1 - 29



- Adjust bottom feed 1 (screw 2) in accordance with the rule.
- Mounting the needle-plate.



Of you mounthe the needle-plate, make sure that the ball-joint 3 of the knife 4 is in the cut-out

Rule

If the knife is max. to the front and the stitch-length setting "0" the edge 5 of the knife 4 should be 0.2 mm a way from the feed dog 6

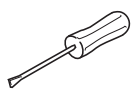
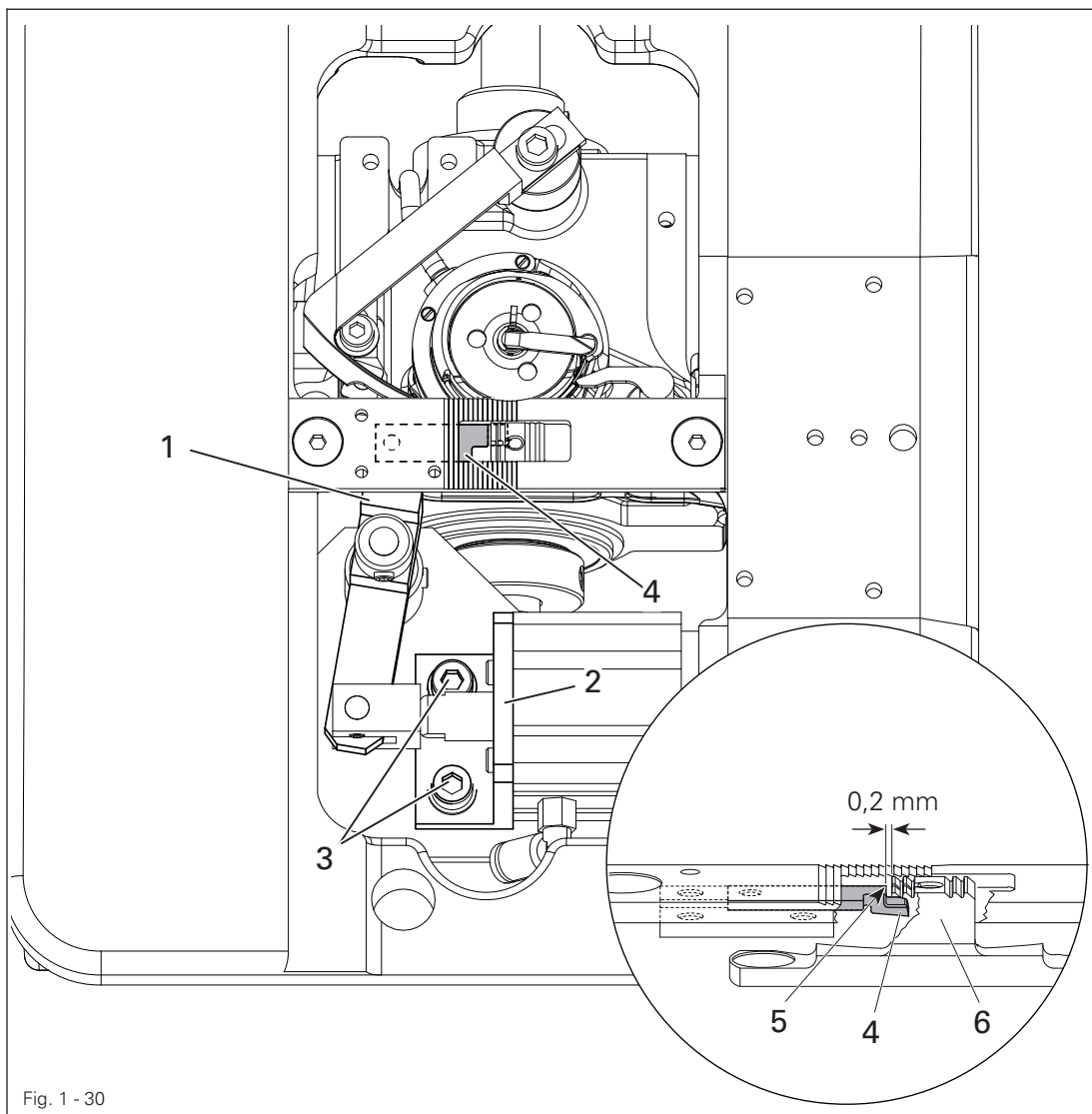

- Set stitch length to "0"
- Move lever 1 to its stop to the front
- Move support 2 (screw 3) according to the setting

1.07.07 Thread catcher height

Rule

When positioning the thread catcher 2 under the setting gauge 1, the thread catcher 2 should directly touch the setting gauge 1 without turning it.

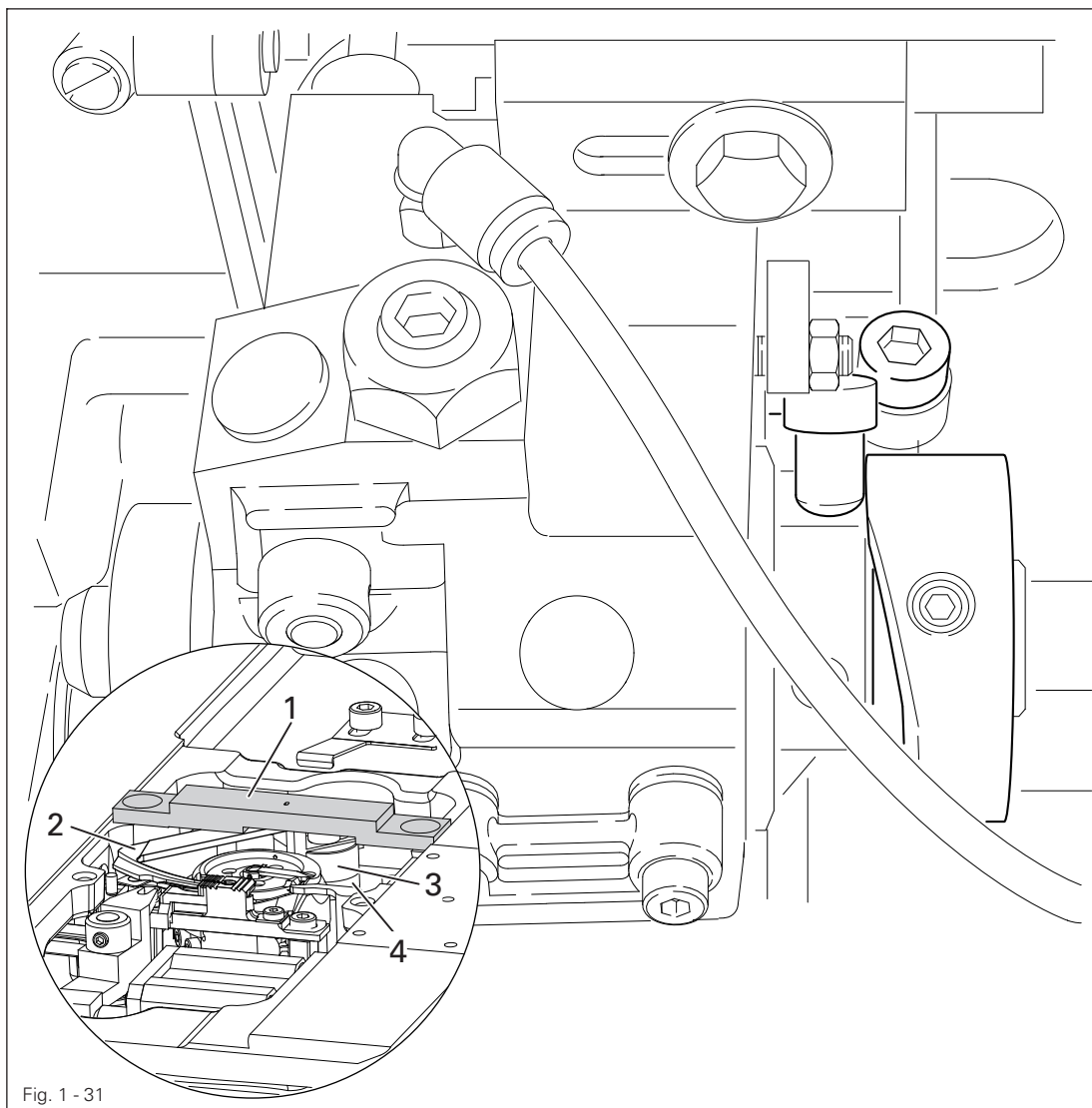
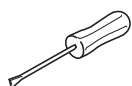

Fig. 1 - 31



- Place the setting gauge 1 (Order No. 61-111 689-07) in the needle plate recess, so that it stands above the thread catcher 2 (see magnification).



The height setting is factory preset.

Any possible correction required can be carried out by placing a **0.2 mm** thick spacing washer underneath (Order No. 12-360 061-05) between part 3 and part 4.

1.07.08 Thread catcher position in sewing direction

Rule

At stitch length setting "0" and the thread catcher 4 in the front turning point position, a gap of 20 mm should exist between the thread catcher point and the middle stitch hole.

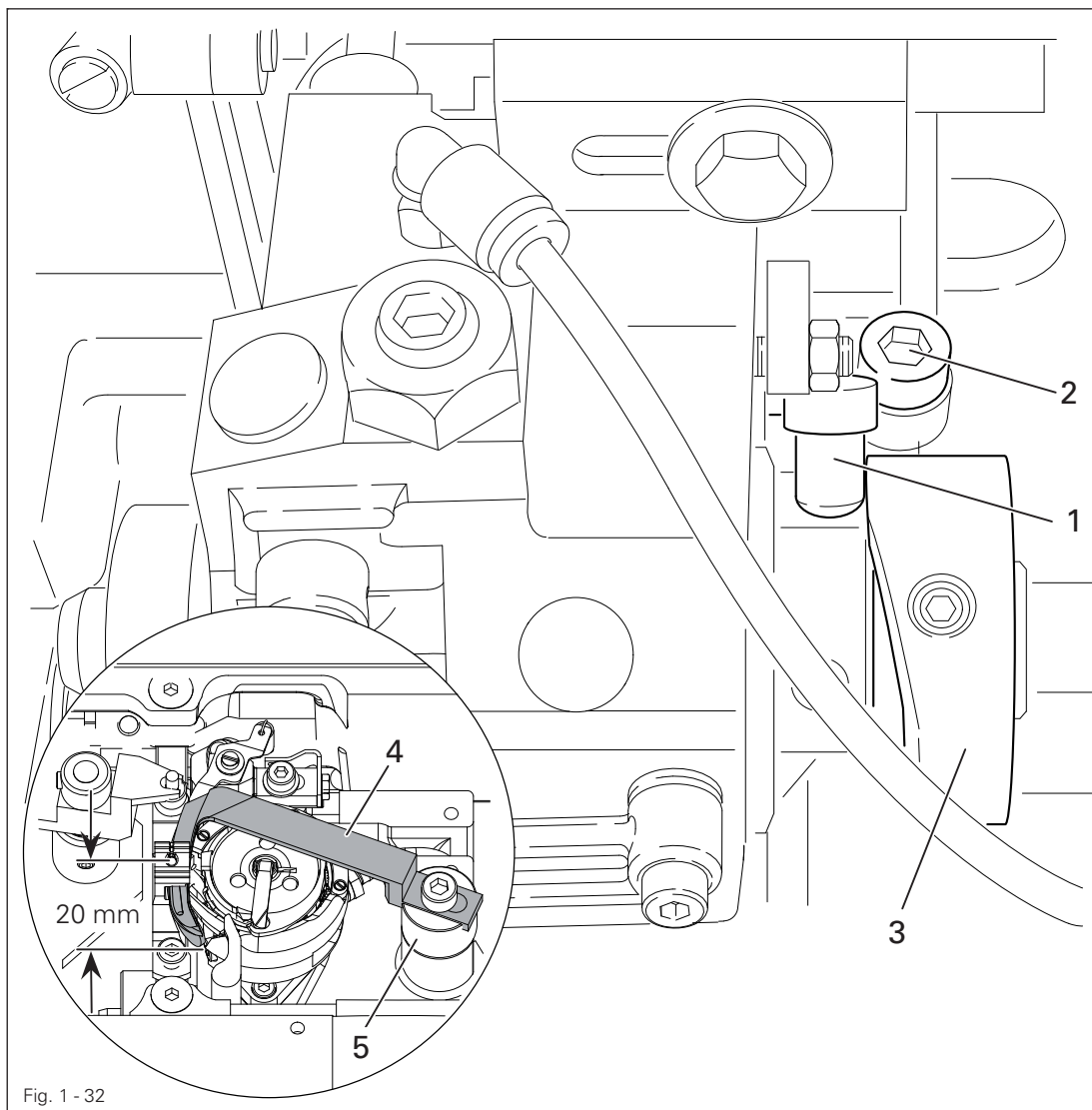
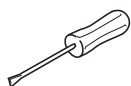

Fig. 1 - 32



- Bring the roller lever 1 (screw 2) to the lowest trim curve position 3.
- Turn thread catcher 4 in accordance with the **rule**
- Make sure that the catcher 5 has no axial play when tighten the screw 2.

1.07.09 Thread catcher position crossways to sewing direction

Rule

In the max. forwards position of the catcher 1, the right edge of the catcher and the right edge of the feed dog 3 be lined up.

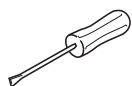
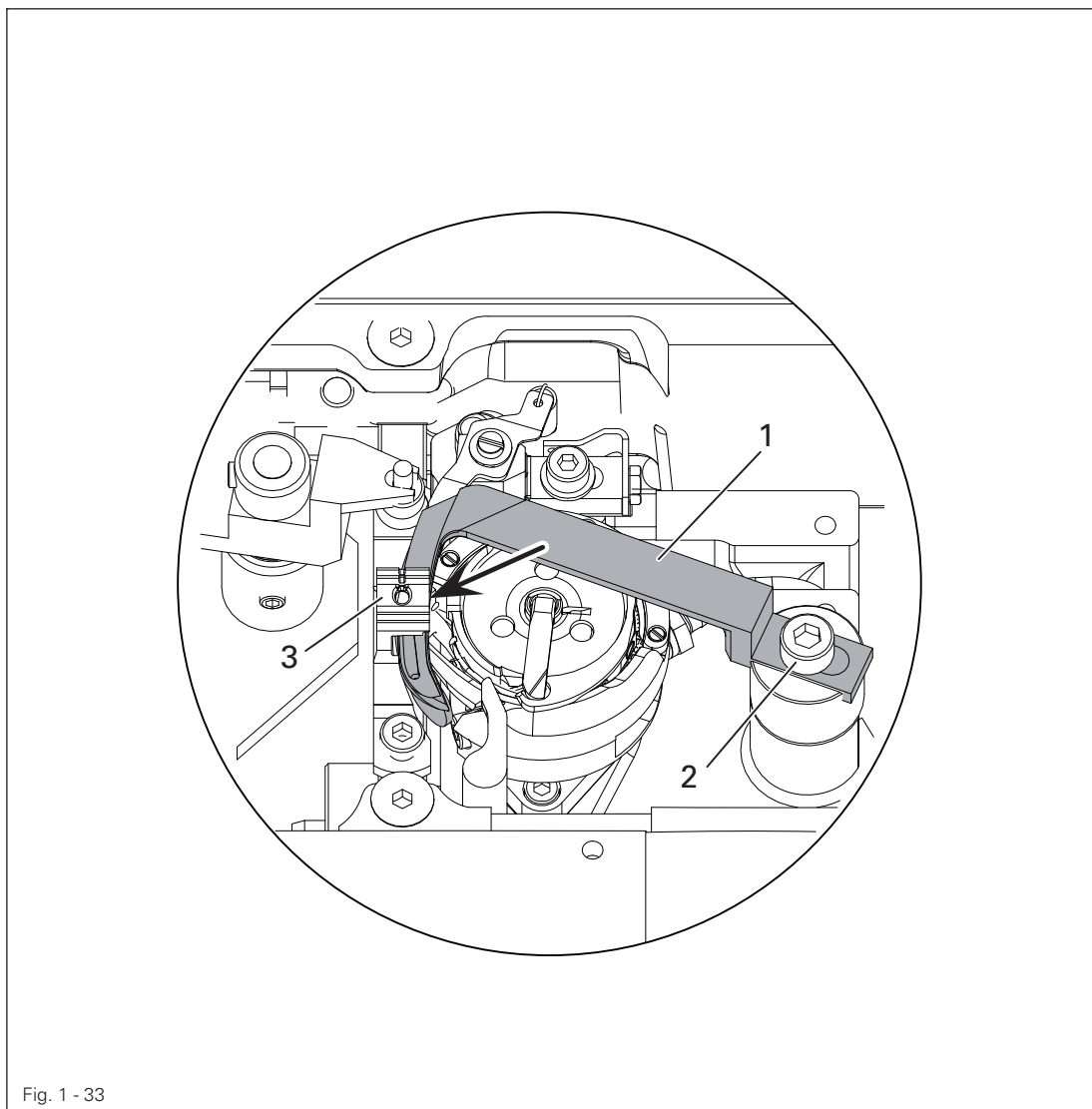

- Move thread catcher 1 (screws 2) in accordance with the rule..

1.07.10 Position of the control curve

Regel

1. In the hand wheel position 305° , the catcher should just start with its movement.
2. When the thread trimmer attachment is in its idle state, a gap of **0.1 mm** should exist between the roller lever **5** and the control curve **1**.

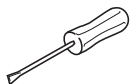
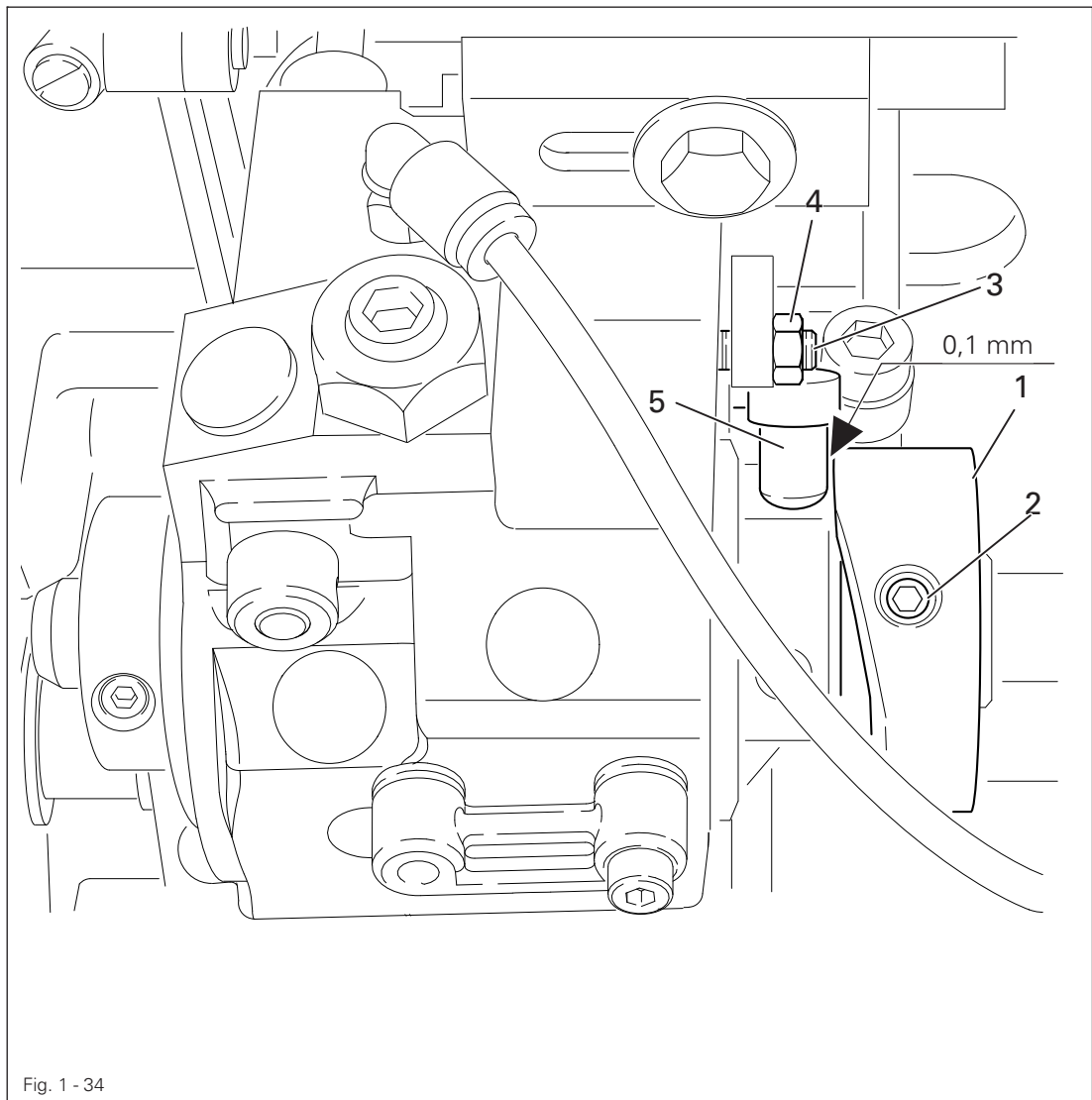

- Turn control curve **1** (screws **2**) in accordance with **rule 1**.
- Adjust screw **3** (nut **4**) in accordance with **rule 2**.

1.07.11 Thread clamp

Rule

1. The right edge of the ripper **1** should be flush with the right edge of the catcher **5** in it's rest position.
2. The ripper **1** should slightly touch the catcher and the top thread gets easy pulled out of the ripper.

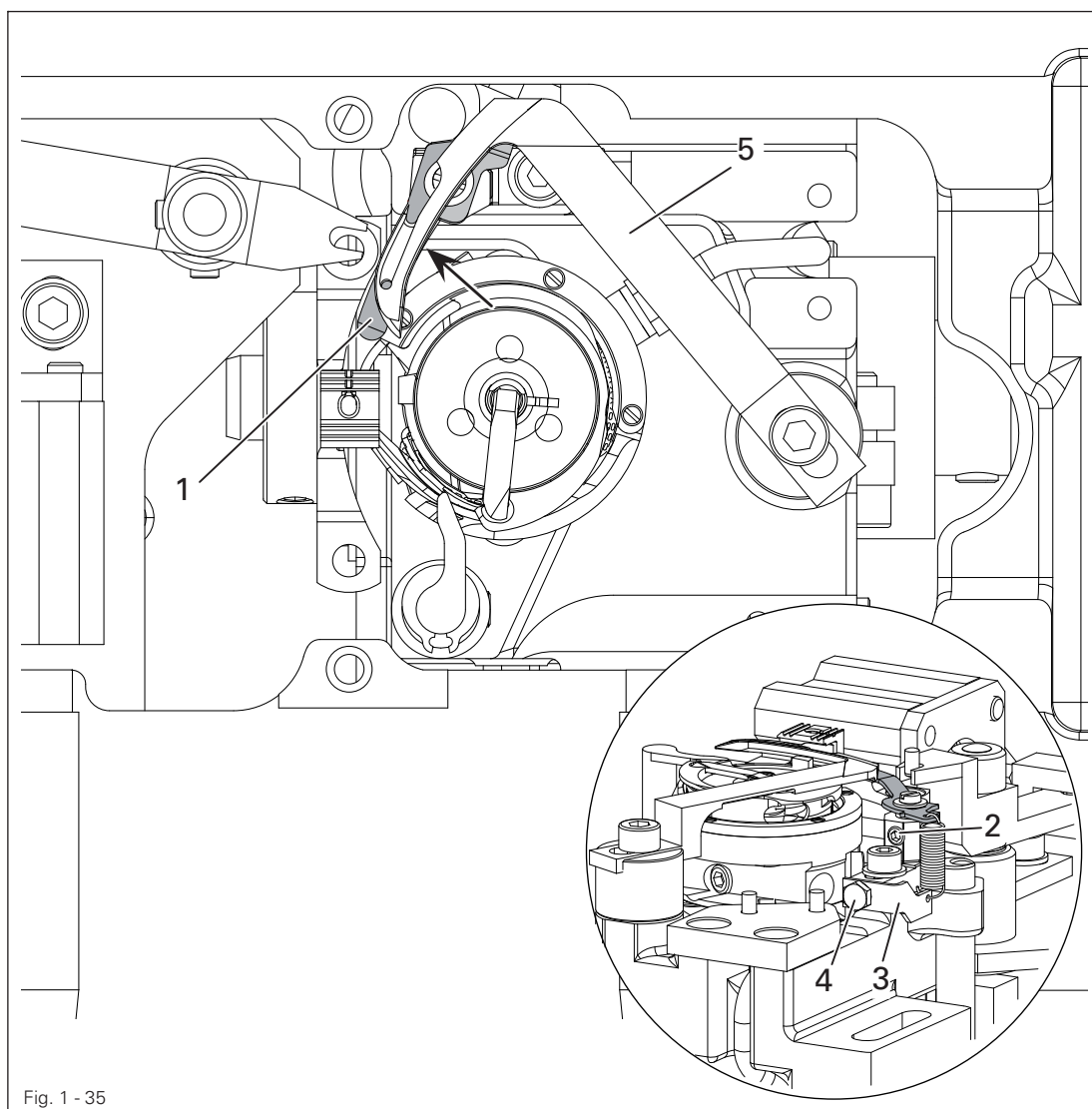
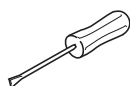

Fig. 1 - 35



- To see better, remove the throat-plate and the feed dog.
- Move the thread-ripper **1** (screw **2**) according to the setting.
- Move support **3** (screw **4**) according to the setting.
- Fix the Thread-plate and the feed dog..



The following parameters has to be set different to the regular P74 ED instruction manual.

Group	Parameter	Description	User level	Setting range	Set value
3	309	Position short trimmer on (-900/81)	B, C	130 - 255	130
		(-900/82)	B, C	180 - 255	180
	310	Funktionen A16 0 = no function 1 = midle guide 2 = short trimmer	B, C	0 - 2	0 (-900/81)
			B, C	0 - 2	2 (-900/82)
	312	Selection of midle guide	B, C	ON - OFF	OFF
	314	Funktionen A7 0 = no function 1 = edge trimmer 2 = thread-pulling sewing start 3 = Engine 4 = Needle cooling 5 = FlipFlop	B, C	0 - 5	1 (-900/81)
B, C			0 - 5	0 (-900/82)	
315	Funktionen A15 0 = no function 1 = Faclean thread-monitor 2 = Thread-pulling at sewing-start 3 = Engine 4 = Needle cooling 5 = FlipFlop	B, C	0 - 5	1 (-900/81)	
		B, C	0 - 5	0 (-900/82)	
316	Position to pull thread at seam-start	B, C	0 - 255	235	
317	Time to pull the thread at sewing-start	B, C	1 - 10	3	
6	657	Stitch protection / knotting	B, C	ON - OFF	ON
7	702	1 Needle position (down)	B, C	0 - 255	20
	703	Thread lever position up	B, C	0 - 255	235
	705	End trim signal1	B, C	0 - 255	120 (-900/81) 210 (-900/82)
	706	Start trim signal	B, C	0 - 255	50 (-900/81) 100 (-900/82)
707	Start thread tension release	B, C	0 - 255	190	
9	989	Thread-nipper at sewing-start 0 = Thread-nipper off 1 = Thread-nipper without foot-lift 2 = Thread-nipper with foot-lift	B, C	0 - 2	1

2 Circuit diagrams

2.01 Block diagram PFAFF 2545 and 2546 BASIC with control pack P45 PD-L

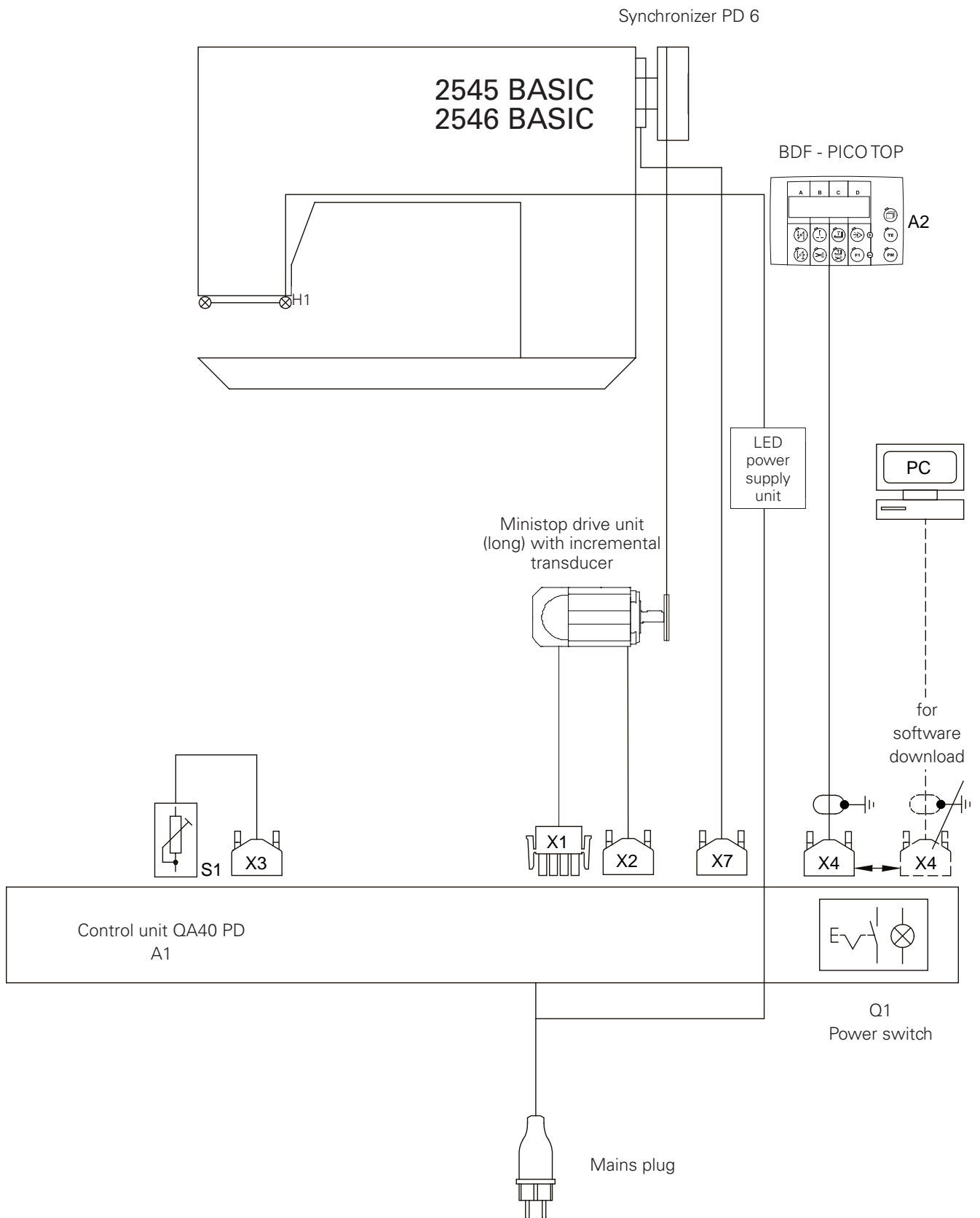

2.02 Circuit diagrams PFAFF 2545 and 2546 BASIC

Reference list for the Circuit diagrams 91-191 523-95

A1	Controller P45 PD-L
A2	Control panel (PicoTop)
H1	Sewing lamp
M1	Sewing motor
Q1	Main switch
S1	Pedal speed control unit
X1	Sewing motor
X2	Incremental transmitter
X7	Synchronizer PD 6
X3	Speed control unit
X4	PicoTop control panel or RS 232 interface (PC)
X5	Input/output plug
X8	Light barrier plug (optional)

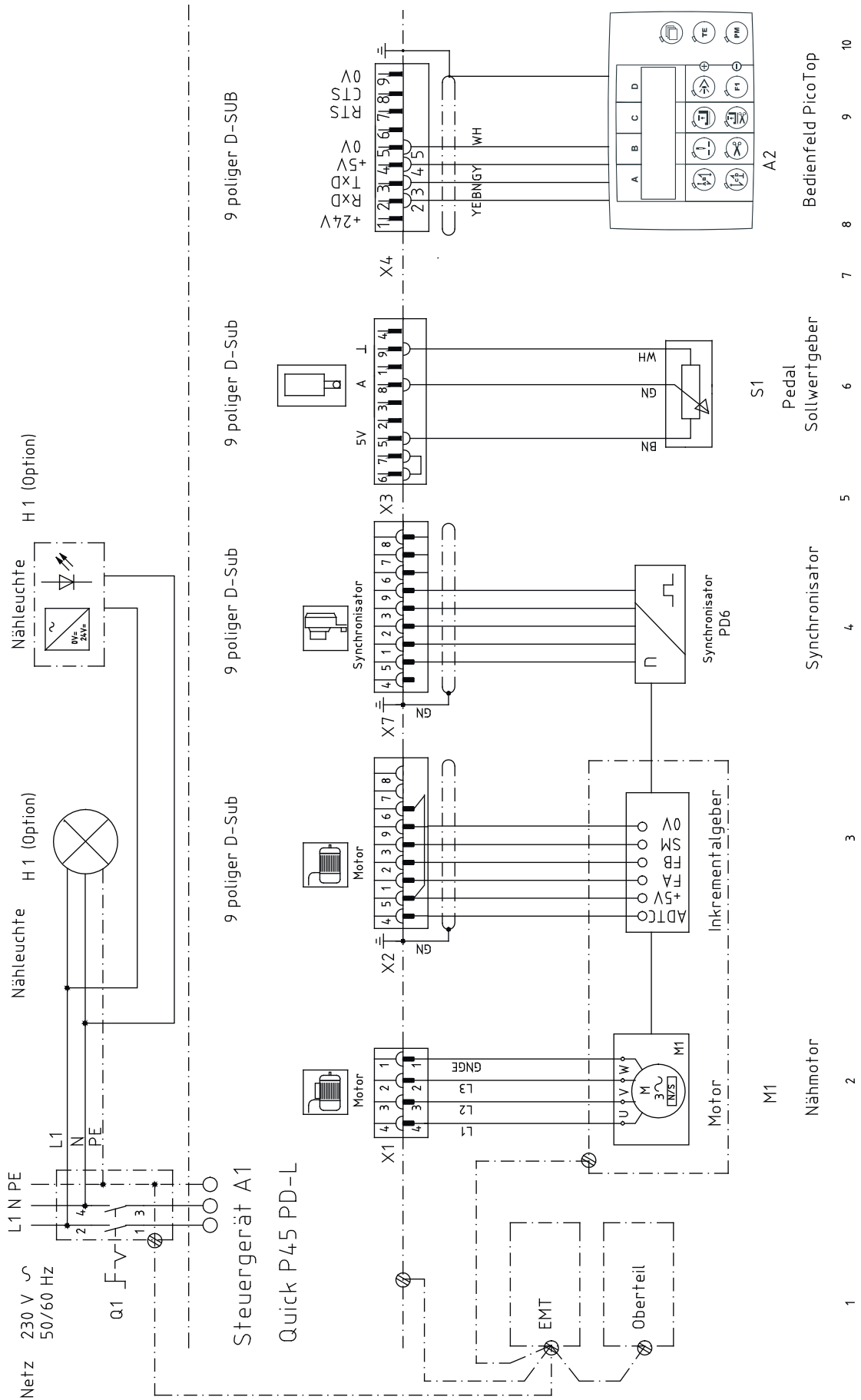

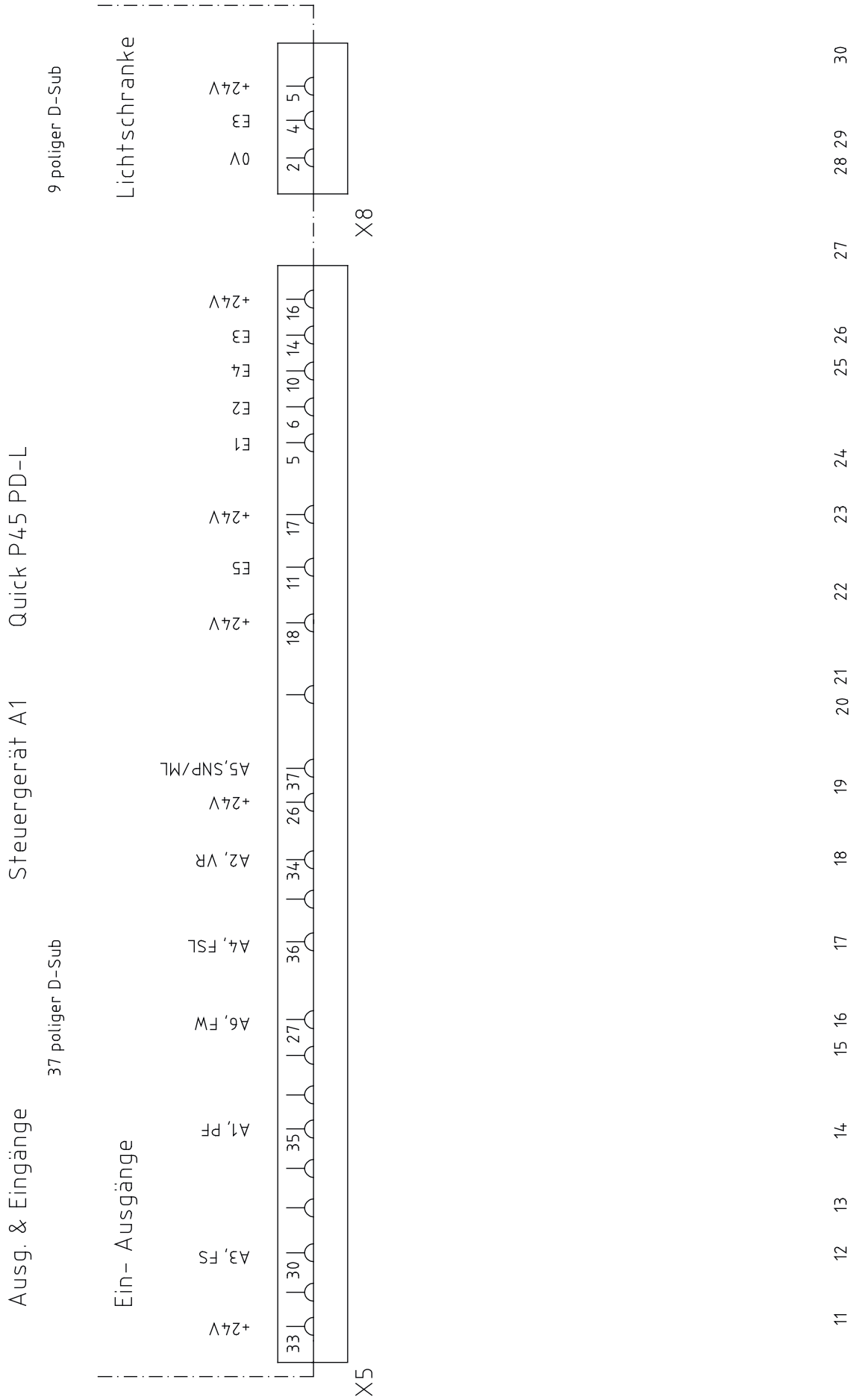

2.03 Block diagram PFAFF 2545 2546 PLUS with control pack P74 ED-L

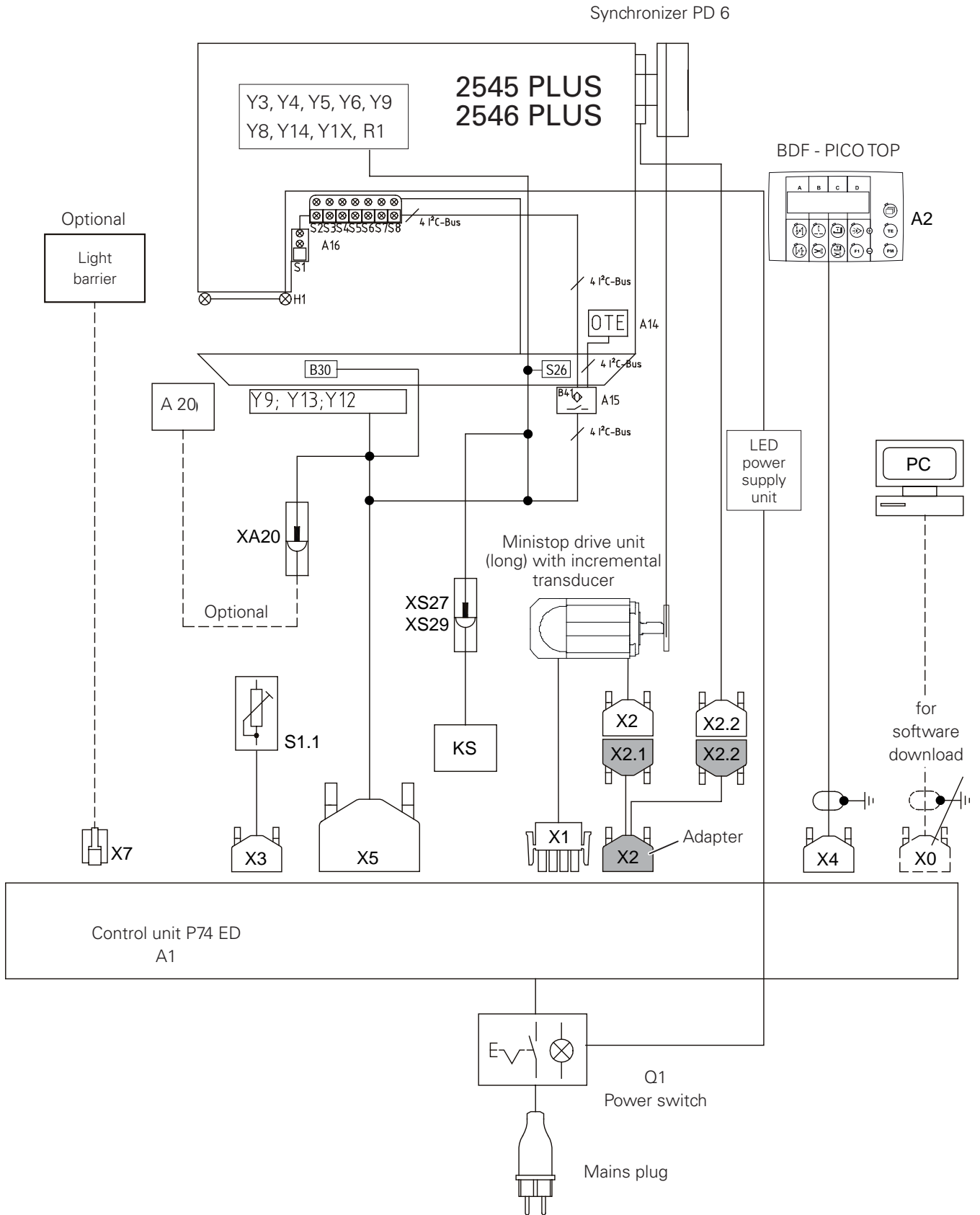

2.04 Circuit diagrams PFAFF 2545 and 2546 PLUS

Reference list for the Circuit diagrams 91-191 519-95

A1	Steuergerät P74 ED-L	X3	Speed control unit
A1	Controller P74 ED-L	X4	PicoTop control panel
A2	Control panel (PicoTop)	X5	Input/output plug
A14	Sewing head recognition (OTE)	X7	Light barrier plug & bobbin thread monitor (optional)
A15	Oil sensor (2C-Bus)		
A16	Keyboard (2C-Bus)	XA14	A14 Sewing head recognition (OTE)
A20/1	Bobbin thread monitor 1 (optional)	XA15.1	A15 Oil sensor (2C-Bus)
A20/2	Bobbin thread monitor 2 (optional)	XA15.2	A15 Oil sensor (2C-Bus) > A16 Keyboard (2C-Bus)
B30	Slider monitoring (optional)		
B41	Oil sensor (2C-Bus)	XA20	A20 Bobbin thread monitor (optional)
H1	Sewing lamp	XR1	R1 Potentiometer for reduced speed during stroke adjustment
R1	Potentiometer for reduced speed during stroke adjustment	XS26	Start inhibitor
		XS27	Stroke control
M1	Sewing motor	XS28	Speed limitation from 9mm stitch length on
Q1	Main switch	XS29	Centre guide
S1.1	Pedal speed control unit	XY3	Y3 Thread clamp (-909/..)
S1	Key 1 depending on parameter other function	XY4	Y4 Presser foot lift (-910/..)
		XY5	Y5 Backtacking device (-911/..)
S2	Key 2 depending on parameter other function	XY6	Y6 Stroke adjustment (-918/26)
		XY8	Y8 Thread tension release
S3	Key 3 depending on parameter other function	XY9	Y9 Thread trimmer (-900/..)
		XY12	Y12 2nd stitch length quick adjustment (-918/29)
S4	Key 4 depending on parameter other function	XY13	Y13 Trim stitch
S5	Key 5 depending on parameter other function	XY14	Y14 Thread tension control
		XY15	Y15 Hook cleaning A20 Bobbin thread monitor (-926/..)
S6	Key 6 depending on parameter other function	Y3	Thread clamp (-909/..)
		Y4	Presser foot lift (-910/..)
S7	Key 7 depending on parameter other function	Y5	Backtacking device (-911/..)
		Y6	Stroke adjustment (-918/26)
S8	Key 8 Emergency off	Y8	Thread tension release
S26	Start inhibitor	Y9	-900/.. Thread trimmer
S27	Stroke adjustment	Y12	2nd stitch length (-918/29)
S28	Speed limitation from 9mm stitch length on	Y13	Trim stitch
		Y14	Thread tension control
S29	Centre guide	Y15	Hook cleaning A20 Bobbin thread monitor (-926/..) optional
X0	RS232 interface (PC)		
X1	Sewing motor	Y16	Centre guide unit (only on the 2546) or -900/82
X2	Incremental transmitter		
X2.1	Incremental transmitter		
X2.2	Synchronizer PD 6		

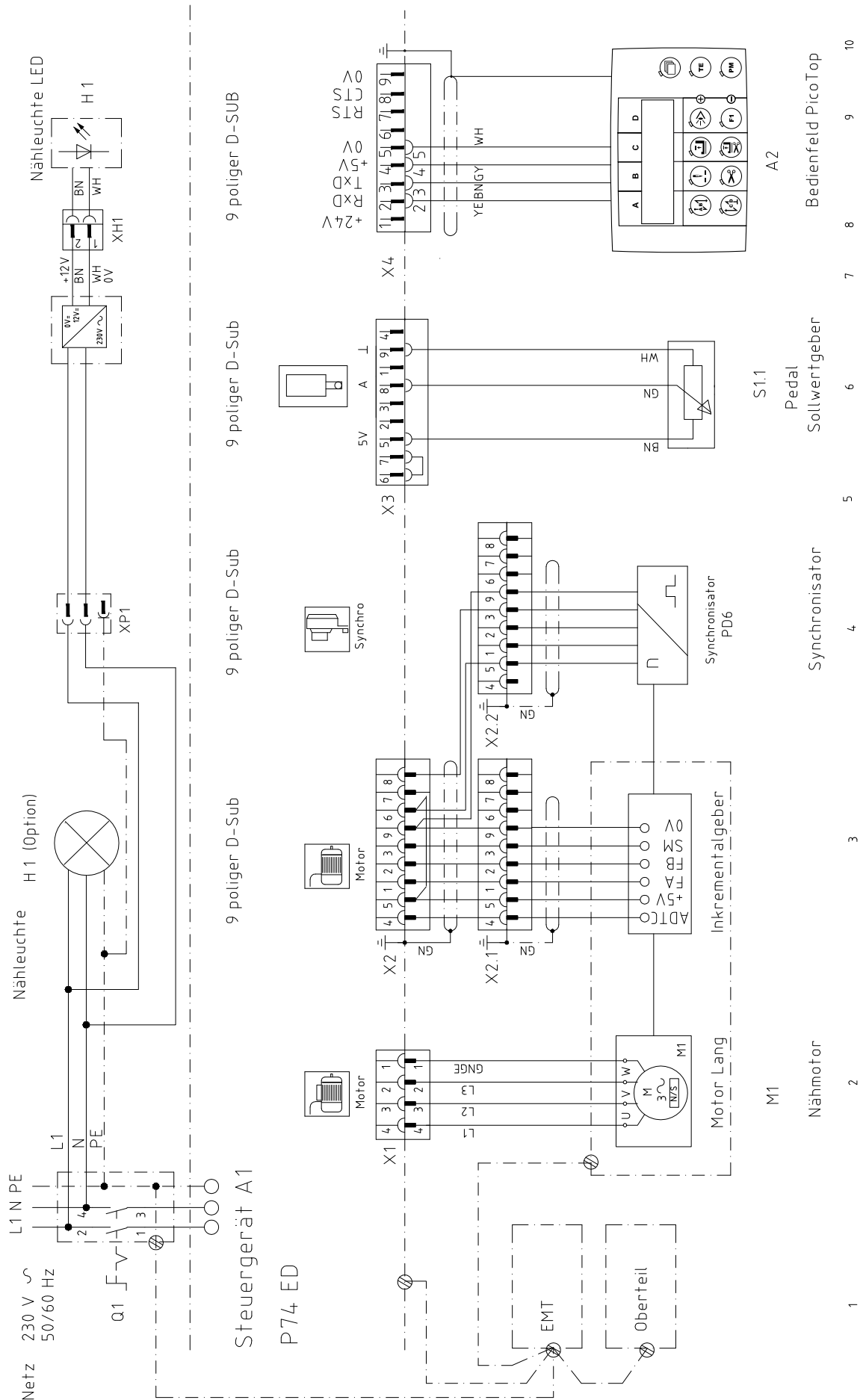

1

2

3

4

5

6

7

8

10

Steuergerät A1 P74 ED

Ausgänge

37 poliger D-Sub

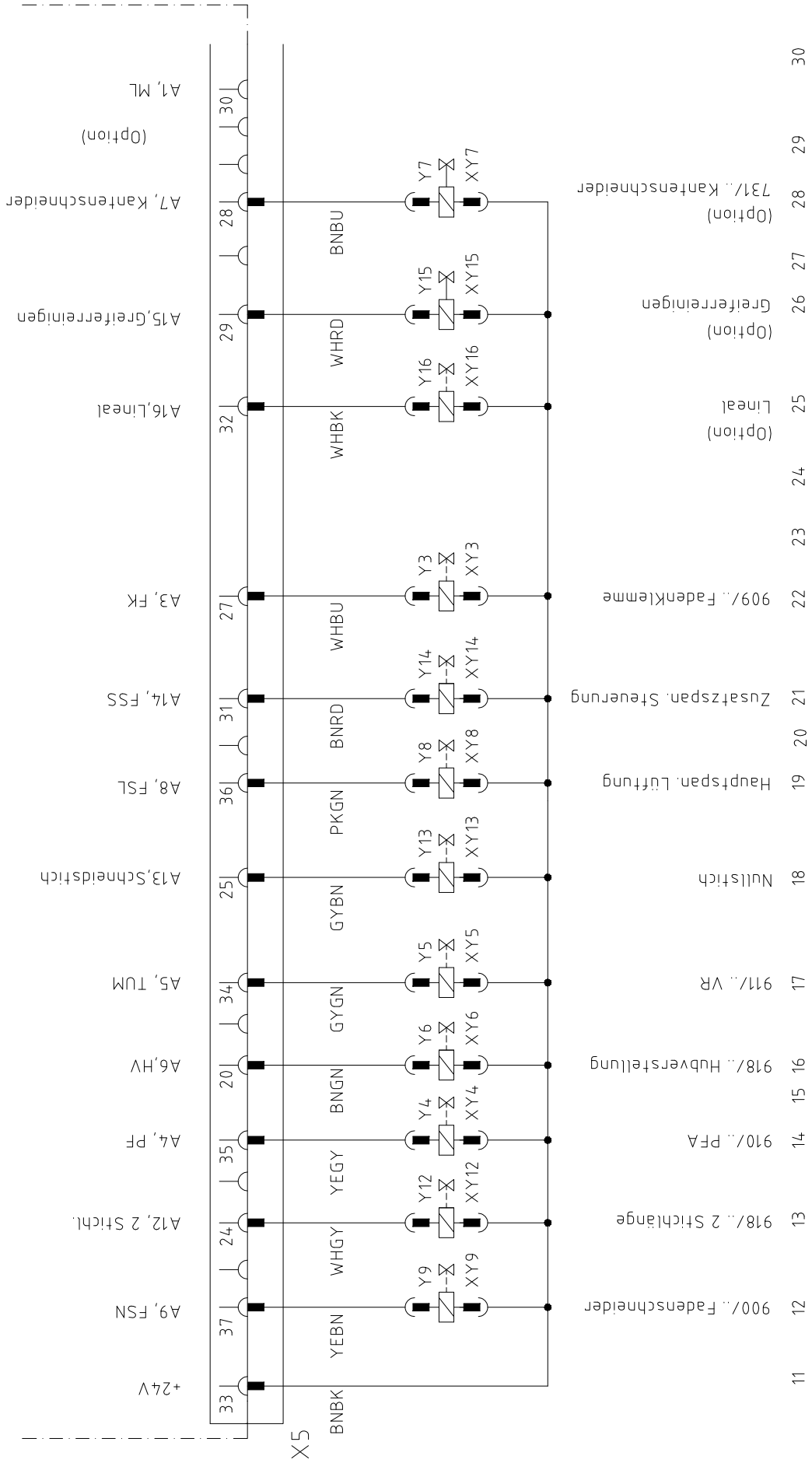

Steuergerät A1 P74 ED

Eingänge

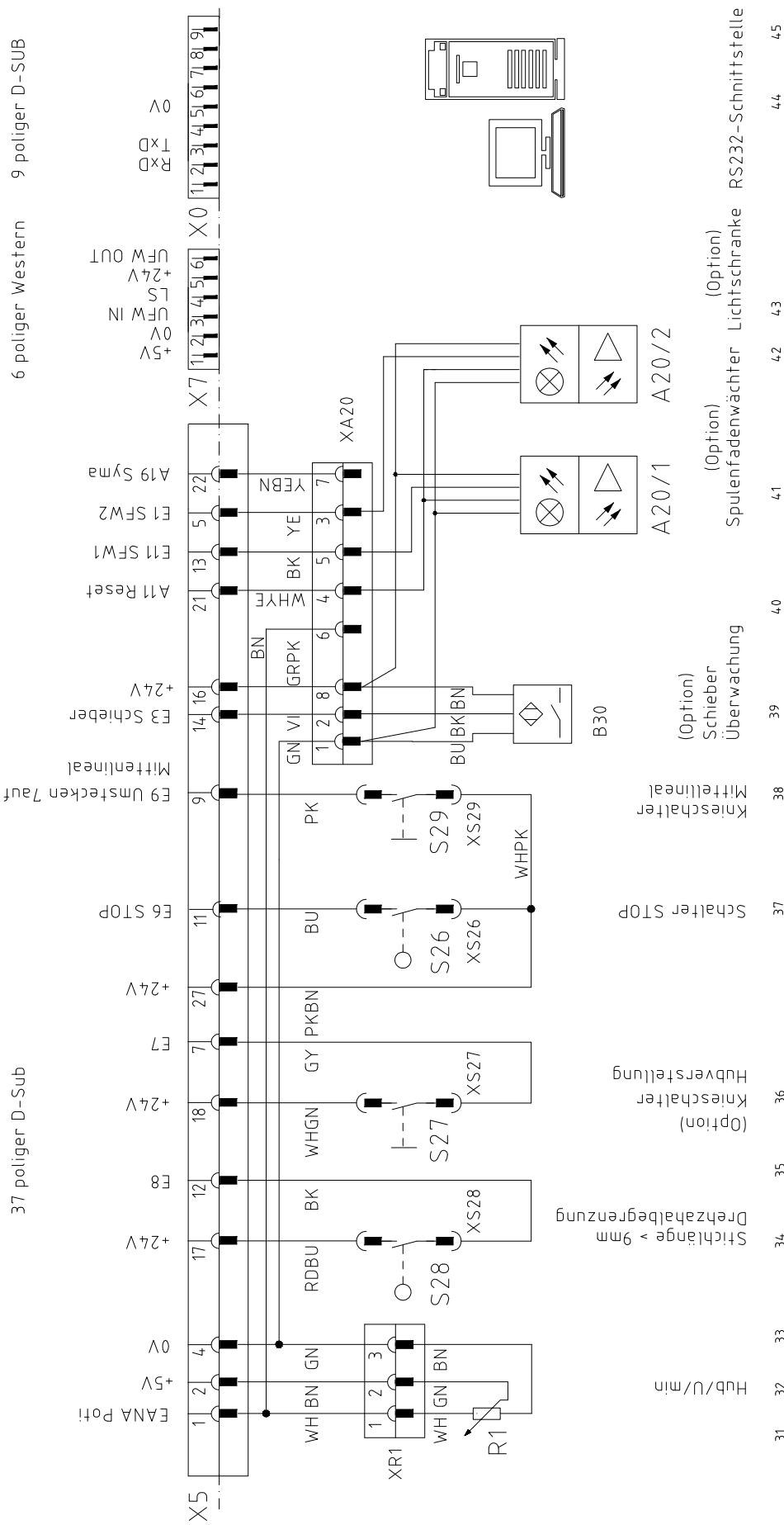

Steuergerät A1 P74 ED

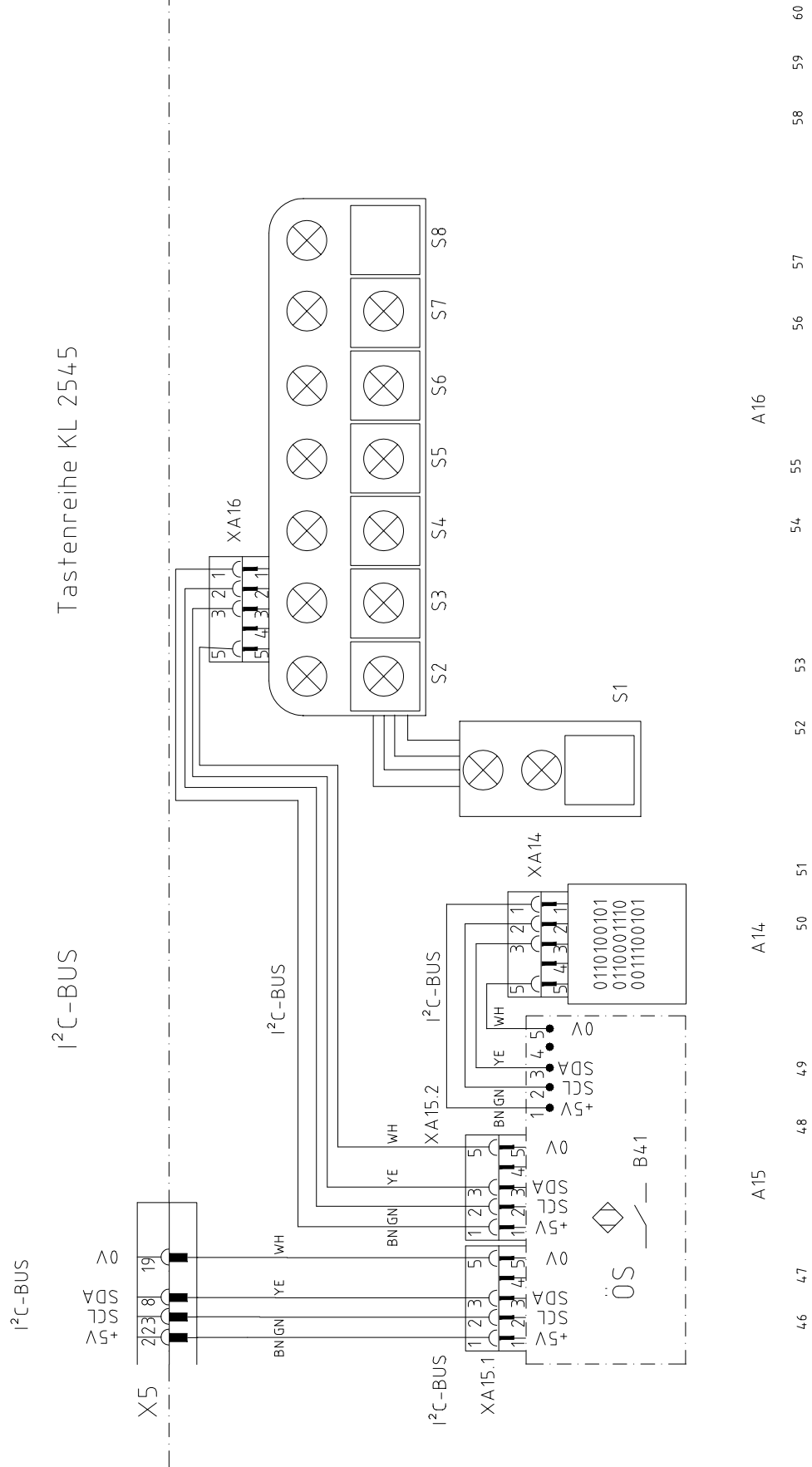

Block diagram

2.05

Block diagram PFAFF 2545/46 PLUS with PF 321

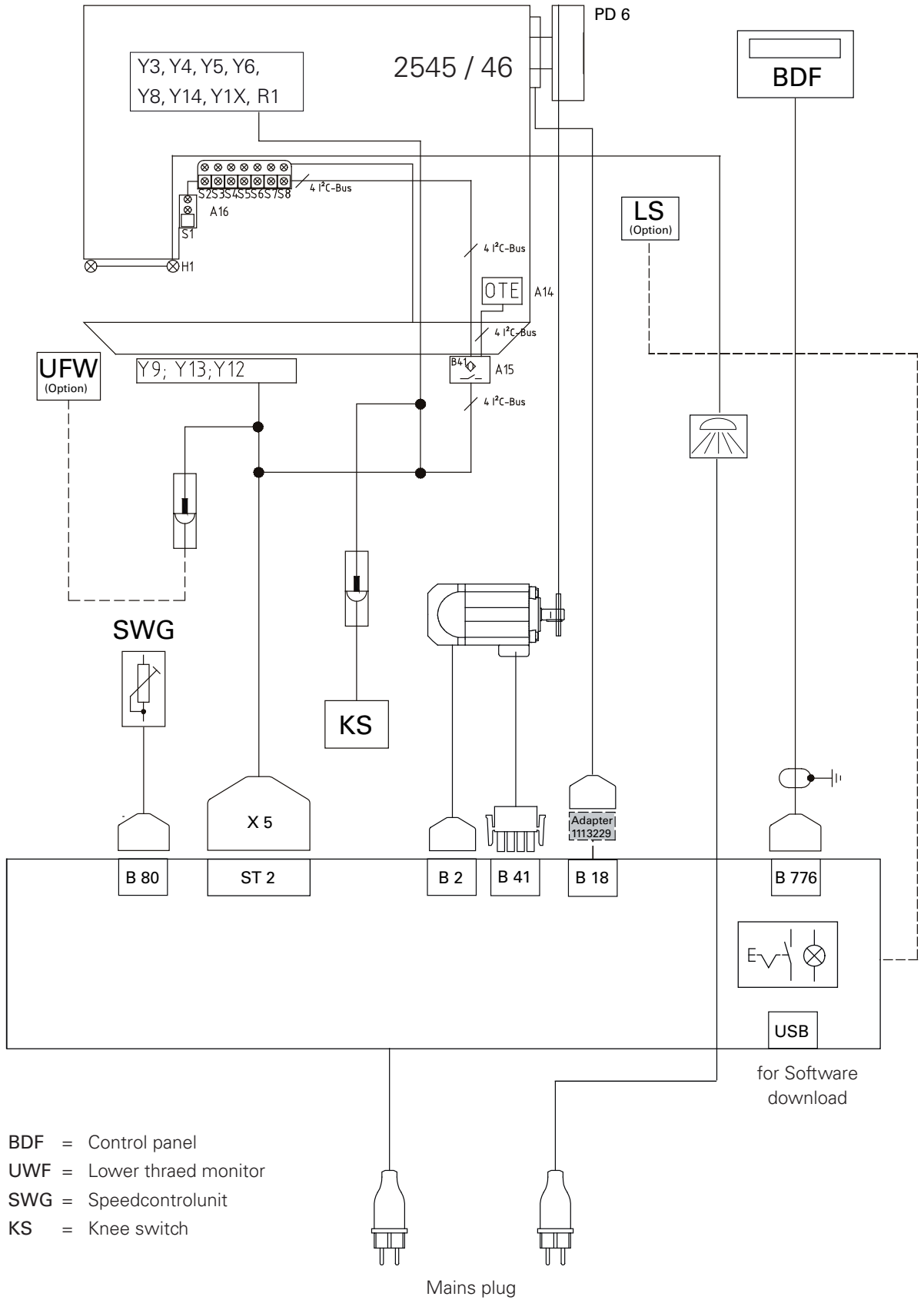



Europäische Union
Wachstum durch Innovation – EFRE



PFAFF Industriesysteme und Maschinen AG

Hans-Geiger-Str. 12 - IG Nord
D-67661 Kaiserslautern

Phone: +49-6301 3205 - 0
Fax: +49-6301 3205 1386
E-mail: info@pfaff-industrial.com

Hotlines:

Technical service: +49-175/2243-101
Application consultancy: +49-175/2243-102
Spare-parts hotline: +49-175/2243-103

Printed in Germany