

571

574

INSTRUCTION MANUAL

591

This instruction manual applies to machines from the following serial numbers onwards:

7 250 050 →



This Instruction Manual is valid for all models and subclasses listed in the chapter "**Specifications**".



The adjustment manual for the machines can be downloaded free of charge from the internet address

www.pfaff-industrial.com/pfaff/de/service/downloads

As an alternative to the internet download the adjustment manual can also be ordered in book form under part no. **296-12-19 233/002**.

The reprinting, copying or translation of PFAFF Instruction manuals, whether in whole or in part, is only permitted with our previous authorization and with written reference to the source.

**PFAFF Industriesysteme
und Maschinen AG**

Hans-Geiger-Str. 12 - IG Nord
D-67661 Kaiserslautern

Contents		Page
1	Safety	5
1.01	Directives.....	5
1.02	General notes on safety.....	5
1.03	Safety symbols	6
1.04	Important points for the user.....	6
1.05	Operating and specialist personnel.....	7
1.05.01	Operating personnel	7
1.05.02	Specialist personnel.....	7
1.06	Danger warnings.....	8
2	Proper use	9
3	Specifications ▲	10
3.01	PFAFF 571, 574, 591	10
3.02	Needles and threads.....	11
3.02	Possible models and subclasses	11
4	Disposal of Machine	12
5	Transportation, packing and storage.....	13
5.01	Transportation to customer's premises	13
5.02	Transportation inside the customer's premises.....	13
5.03	Disposal of packing materials	13
5.04	Storage	13
6	Explanation of symbols.....	14
7	Controls	15
7.01	On/off switch	15
7.02	Keys on the machine head (only for machines with -911/..)	15
7.03	Bobbin thread monitoring with stitch counting (only on machines with EcoDrive)	16
7.04	Pedal	16
7.05	Lever for lifting roller presser	17
7.06	Knee lever.....	17
7.07	Key for setting stitch length	18
7.08	Swing out roller presser.....	18
7.09	Edge trimmer -725/04 for 571.....	19
7.10	Edge trimmer -725/04 for 591	20
7.11	Control panel (only on machines with Eco drive or Pico drive)	21
8	Installation and commissioning	22
8.01	Installation.....	22
8.01.01	Adjusting the table-top height.....	22
8.01.02	Fitting the tilt lock.....	23
8.01.03	Fitting the machine cover.....	23
8.02	Mounting the flange motor.....	24
8.02.01	Mounting the flange motor to the bearing plate.....	24
8.02.02	Mounting the flange motor to the machine.....	24

	Contents	Page
8.02.03	Mounting the toothed belt and adjusting the tension.....	25
8.02.04	Mounting the belt guard of the flange motor	25
8.03	Connecting the plug-in connections and earth cables	26
8.04	Connecting the safety switch	27
8.05	Checking the start inhibitor function	27
8.06	Fitting the reel stand.....	28
8.07	Commissioning	28
8.08	Switching the machine on/off	28
8.09	Basic position of the machine drive unit	29
8.09.01	On machines with EcoDrive and control unit P40 ED	29
8.09.02	On machines with PicoDrive and control unit P44 PD-L.....	30
9	Setting up	31
9.01	Inserting the needle.....	31
9.02	Winding the bobbin thread, adjusting the thread tension.....	32
9.03	Removing/Inserting the bobbin case	33
9.04	Threading the bobbin case/Adjusting the bobbin thread tension.....	33
9.05	Threading the needle thread and regulating its tension on model 571 and 591	34
9.06	Threading the needle thread and regulating its tension on model 574	35
9.07	Setting the stitch length.....	36
9.08	Adjusting the stitch counter for the bobbin thread control (only on machines with Motor and P40 (ED) control unit)	36
10	Care and maintenance.....	37
10.01	Servicing and maintenance intervals	37
10.02	Cleaning	37
10.03	Oiling the hook.....	38
10.04	Oil bowl for hook lubrication	38
10.05	Lubricating the bevel gears.....	39
10.06	Filling the oil reservoir of the thread lubrication unit.....	40
10.07	Parameter settings	40
10.07.01	Parameter list.....	40
11	Mounting the table top.....	42
11.01	Tilted work base	42
11.02	Table top cutout	42
11.03	Mounting the table top (with EcoDrive and control unit P 40 ED)	43
11.04	Mounting the table top (with PicoDrive and control unit P44 PD-L)	44
11.05	Circuit diagrams	45
11.05.01	Reference list for the Circuit diagrams 91-191 524-95 and 91-191 534-95	45
11.05.02	Block diagram PFAFF 570 / 590 with control unit P40 ED	47
11.05.03	Circuit diagrams 91-191 524-95	48
11.05.04	Block diagram PFAFF 570 / 590 with control unit P44 PD-L	50
11.05.05	Circuit diagrams 91-191 534-95	51
12	Wearing parts	53

1 Safety

1.01 Directives

This machine is constructed in accordance with the European regulations contained in the conformity and manufacturer's declarations.

In addition to this Instruction Manual, also observe all generally accepted, statutory and other regulations and legal requirements and all valid environmental protection regulations! The regionally valid regulations of the social insurance society for occupational accidents or other supervisory organizations are to be strictly adhered to!

1.02 General notes on safety

- This machine may only be operated by adequately trained operators and only after having completely read and understood the Instruction Manual!
- All Notes on Safety and Instruction Manuals of the motor manufacturer are to be read before operating the machine!
- The danger and safety instructions on the machine itself are to be followed!
- This machine may only be used for the purpose for which it is intended and may not be operated without its safety devices. All safety regulations relevant to its operation are to be adhered to.
- When exchanging sewing tools (e.g. needle, roller presser, needle plate and bobbin), when threading the machine, when leaving the machine unattended and during maintenance work, the machine is to be separated from the power supply by switching off the On/Off switch or by removing the plug from the mains!
- Everyday maintenance work is only to be carried out by appropriately trained personnel!
- Repairs and special maintenance work may only be carried out by qualified service staff or appropriately trained personnel!
- Work on electrical equipment may only be carried out by appropriately trained personnel!
- Work is not permitted on parts and equipment which are connected to the power supply! The only exceptions to this rule are found in the regulations EN 50110.
- Modifications and alterations to the machine may only be carried out under observance of all the relevant safety regulations!
- Only spare parts which have been approved by us are to be used for repairs! We expressly point out that any replacement parts or accessories which are not supplied by us have not been tested and approved by us. The installation and/or use of any such products can lead to negative changes in the structural characteristics of the machine. We are not liable for any damage which may be caused by non-original parts.

1.03 Safety symbols



Danger!
Points to be observed..



Danger of injury for operating and specialist personnel!



Caution

Do not operate without finger guard and safety devices.
Before threading, changing bobbin and needle, cleaning etc. **switch off main switch.**

1.04 Important points for the user

- This Instruction Manual is an integral part of the machine and must be available to the operating personnel at all times.
- The Instruction Manual must be read before operating the machine for the first time.
- The operating and specialist personnel is to be instructed as to the safety equipment of the machine and regarding safe work methods.
- It is the duty of the user to only operate the machine in perfect running order.
- It is the obligation of the user to ensure that none of the safety mechanisms are removed or deactivated.
- It is the obligation of the user to ensure that only authorized persons operate and work on the machine.

Further information can be obtained from your PFAFF agent.

1.05 Operating and specialist personnel

1.05.01 Operating personnel

Operating personnel are persons responsible for the equipping, operating and cleaning of the machine as well as for taking care of problems arising in the sewing area.

The operating personnel is required to observe the following points and must:

- always observe the Notes on Safety in the Instruction Manual!
- never use any working methods which could adversely affect the safety of the machine!
- not wear loose-fitting clothing or jewelery such as chains or rings!
- also ensure that only authorized persons have access to the potentially dangerous area around the machine!
- always immediately report to the person responsible any changes in the machine which may limit its safety!

1.05.02 Specialist personnel

Specialist personnel are persons with a specialist education in the fields of electrics, electronics and mechanics. They are responsible for the lubrication, maintenance, repair and adjustment of the machine.

The specialist personnel is obliged to observe the following points and must:

- always observe the Notes on Safety in the Instruction Manual!
- switch off the On/Off switch before carrying out adjustments or repairs, and ensure that it cannot be switched on again unintentionally!
- wait until the luminous diode on the control box is no longer blinking or on before beginning adjustment or repair work.
- never work on parts which are still connected to the power supply! Exceptions are explained in the regulations EN 50110.
- replace the protective coverings and close the electrical control box after all repairs or maintenance work!

1.06

Danger warnings



A working area of 1 m must be kept free both in front of and behind the machine, so that easy access is possible at all times.



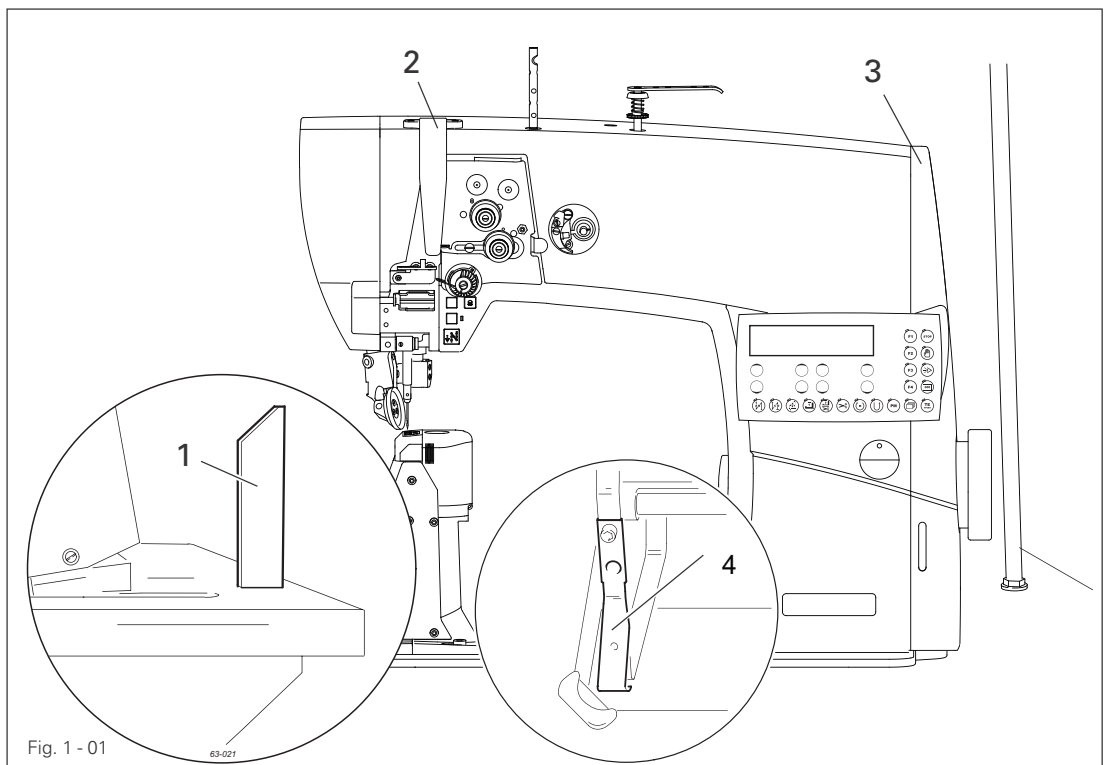
Never put your hands or fingers in the sewing area during sewing!
Danger of injury by the needle!



While setting or adjusting the machine do not leave any objects on the table nor in the needle plate area! Objects may be trapped or flung out of the machine!



Do not operate the machine without support **1!** Danger due to top-heavy sewing head! Machine can tip over backwards when tilted!



Switch the machine off before tilting it backwards!
Danger of injury if the machine is started accidentally!



Do not operate the machine without its take-up-lever guard **2!**
Danger of injury due to the motion of the take-up lever!



Do not operate the machine without belt guard **3!**
Danger of injury by rotating drive belt!



Do not operate the machine without tilt lock **4!**
Danger of crushing between sewing head and table top!

2 **Proper use**

The **PFAFF 571** is a single needle, high-speed post bed sewing machine (post to the left of the needle) with driven feed wheel and roller presser and synchronized needle.

The **PFAFF 574** is a two-needle, high-speed post bed sewing machine with driven feed wheel and roller presser

The **PFAFF 591** is a single needle, high-speed post bed sewing machine (post to the right of the needle) with driven feed wheel and roller presser and synchronized needle.

The machines are used for sewing lockstitch seams in the leather and upholstery industries.



Any and all uses of this machine which have not been approved of by the manufacturer are considered to be inappropriate! The manufacturer cannot be held liable for any damage caused by the inappropriate use of the machine! The appropriate use of the machine includes the observance of all operational, adjustment, maintenance and repair measures required by the manufacturer!

3 Specifications ▲

3.01 PFAFF 571, 574, 591

Stitch type:..... 301 (lockstitch)

Clearance under roller presser:7 mm

Clearance width:245 mm

Clearance height: 115 mm

Post height: 180 mm

Sewing head dimensions:

Length:..... approx. 562 mm

Width: approx. 250 mm

Height (above table): approx. 505 mm

Bedplate dimensions: 518 x 177 mm

Max. speed:

PFAFF 571, 574, 591 Model B 3000 spm ♦

PFAFF 574, 591 Model C 2000 spm ♦

Cutting depth (for -725/..): 0.8 – 2.5 mm

Cutting speed (for -725/..): 2800 cuts/min.

Connection data:

Operating voltage: 230 V ± 10%, 50/60 Hz

Max. power consumption: 1.2 kVA

Fuse protection: 1 x 16 A, inert

Noise data:

Emission sound level at the workplace at appropriate speed

(Noise measurement in accordance with DIN 45 635-48-A-1, ISO 11204, ISO 3744, ISO 4871)

PFAFF 571 and 591, model B at a speed of 2400 spm.: $L_{pA} = 79$ dB(A) ■

PFAFF 574, model C at a speed of 1600 spm.: $L_{pA} = 75$ dB(A) ■

PFAFF 591, model C at a speed of 1600 spm.: $L_{pA} = 73$ dB(A) ■

Net weight of sewing head:..... approx. 63.5 kg

Gross weight of sewing head: approx. 83 kg

▲ Subject to alteration

♦ Dependent on material, work operation and stitch length

■ $K_{pA} = 2,5$ dB

3.02 Needles and threads

Model	Thread thickness (Nm) max. synthetic ▲	Needle thickness in 1/100 mm	Needle system for PFAFF 571	Needle system for PFAFF 574	Needle system for PFAFF 591
B	40-60/3	100	134	134 - 35	134
C	15/3	130	134	134 - 35	134

▲ or similar strengths of other types of thread

3.02 Possible models and subclasses

PFAFF 571, 591

Model B For sewing medium-weight materials

PFAFF 574, 591

Model C For sewing medium-heavy materials

Additional equipment:

Subclass -725/04..... Edge trimmer

Subclass -900/83..... Thread trimmer

Subclass -910/17 Automatic presser foot lifter

Subclass -911/50..... Bartacker

Subclass -940/02..... Needle plate rounded in sewing direction

4

Disposal of Machine

- Proper disposal of the machine is the responsibility of the customer.
- The materials used for the machine are steel, aluminium, brass and various plastic materials. The electrical equipment comprises plastic materials and copper.
- The machine is to be disposed of according to the locally valid pollution control regulations; if necessary, a specialist is to be commissioned.



Care must be taken that parts soiled with lubricants are disposed of separately according to the locally valid pollution control regulations!

5 Transportation, packing and storage

5.01 Transportation to customer's premises

The machines are delivered completely packed.

5.02 Transportation inside the customer's premises

The manufacturer cannot be made liable for transportation inside the customer's premises nor to other operating locations. It must be ensured that the machines are only transported in an upright position.

5.03 Disposal of packing materials

The packing materials of this machine comprise paper, cardboard and VCE fibre. Proper disposal of the packing material is the responsibility of the customer.

5.04 Storage

If the machine is not in use, it can be stored as it is for a period of up to six months, but it should be protected against dust and moisture.

If the machine is stored for longer periods, the individual parts, especially the surfaces of moving parts, must be protected against corrosion, e.g. by a film of oil.

6 Explanation of symbols

In this instruction manual, work to be carried out or important information is accentuated by symbols. These symbols have the following meanings:



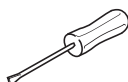
Note, information



Cleaning, care



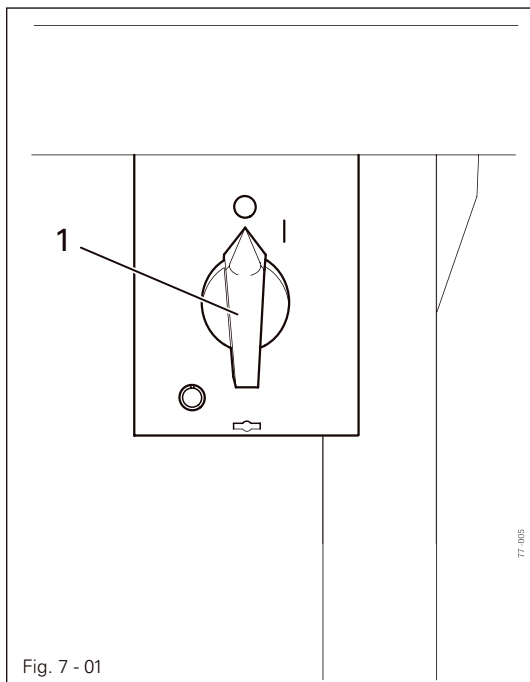
Lubrication



Maintenance, repairs, adjustment, service work
(only to be carried out by technical staff)

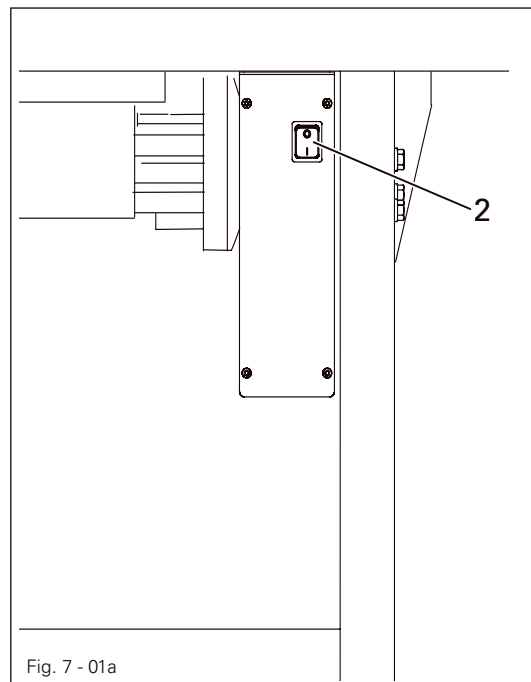
7 Controls

7.01 On/off switch



Machines with EcoDrive

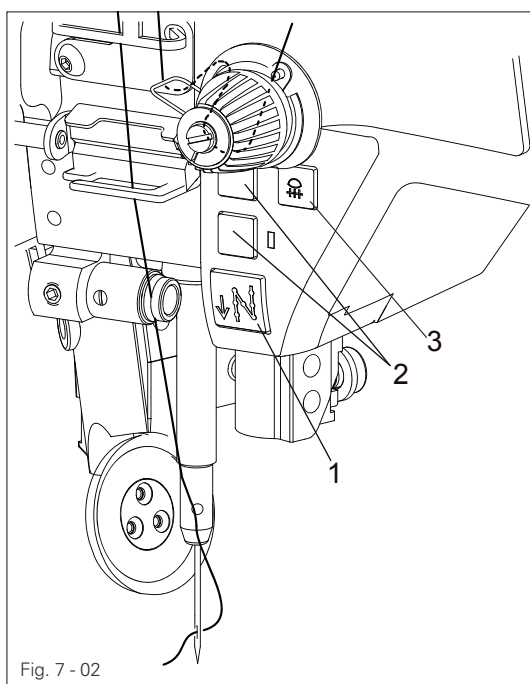
- The power supply to the machine is switched on or off by turning switch 1.



Machines with PicoDrive

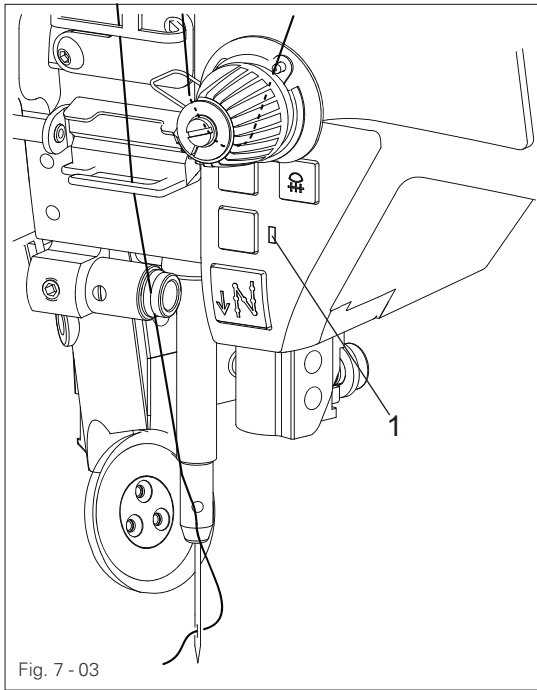
- Operate main switch 2 to switch the machine on or off.

7.02 Keys on the machine head (only for machines with -911/..)



- As long as key 1 is pressed during sewing, the machine sews in reverse.
- Keys 2 can be used for parameter settings (see parameter 446 and 748 in the instruction manual for the motor).
- Switch the sewing lamp, which is integrated in the machine head, on or off by operating switch 3

7.03 Bobbin thread monitoring with stitch counting (only on machines with EcoDrive)

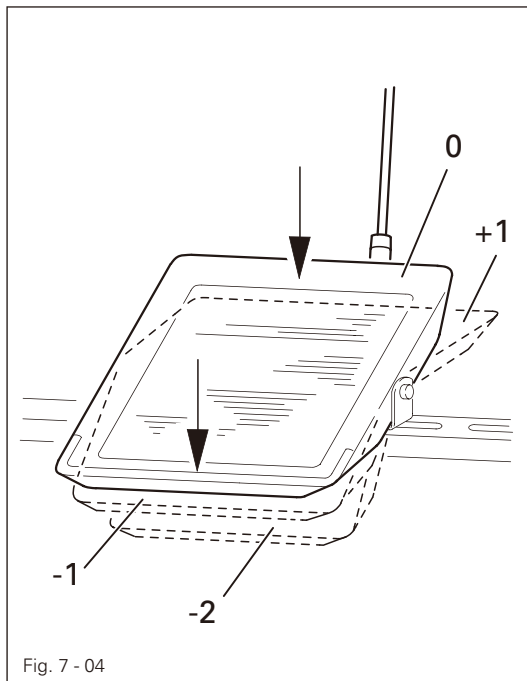


- After the pre-set number of stitches have been sewn, diode 1 flashes.
- After the thread has been trimmed and the bobbin changed, the stitch counting begins anew.



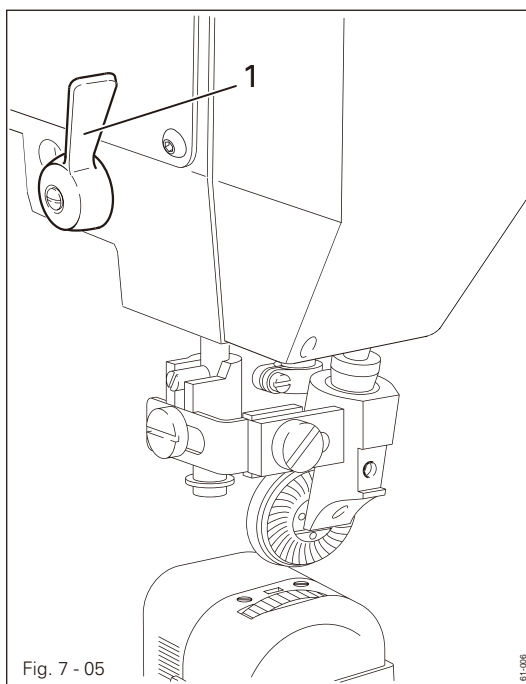
Presetting the number of stitches (see description in the instruction manual for the motor).

7.04 Pedal



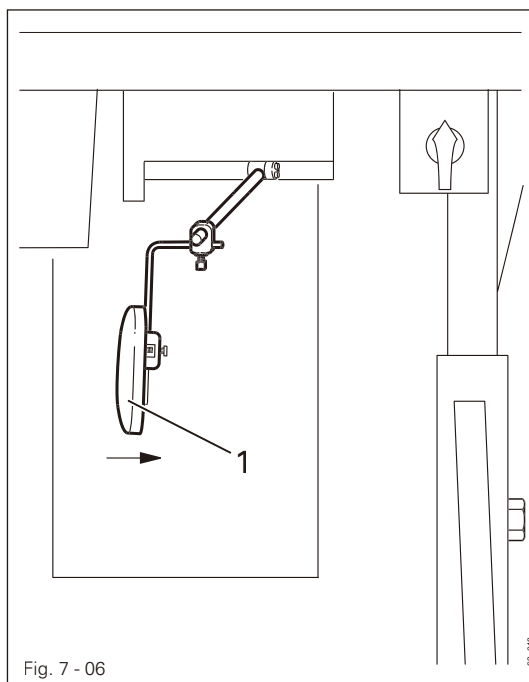
- 0 = Neutral position
- +1 = Sewing
- 1 = Raise roller presser (on machines with -910/..)
- 2 = Trim sewing threads (on machines with -900/..)

7.05 Lever for lifting roller presser



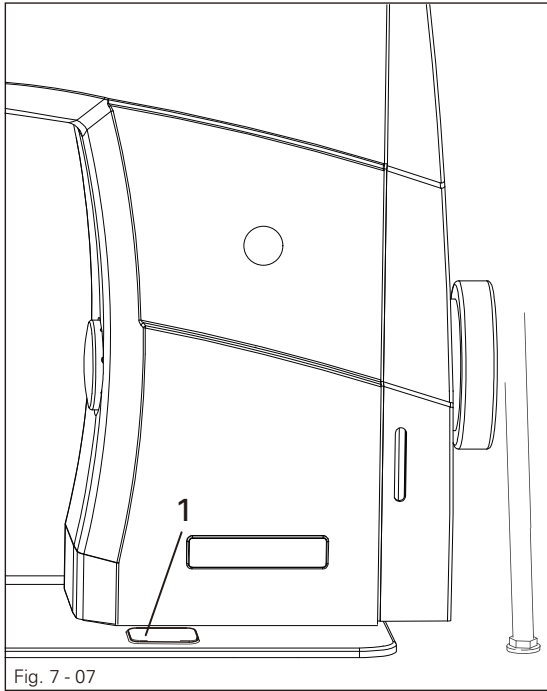
- The roller presser can be raised by turning lever 1.

7.06 Knee lever



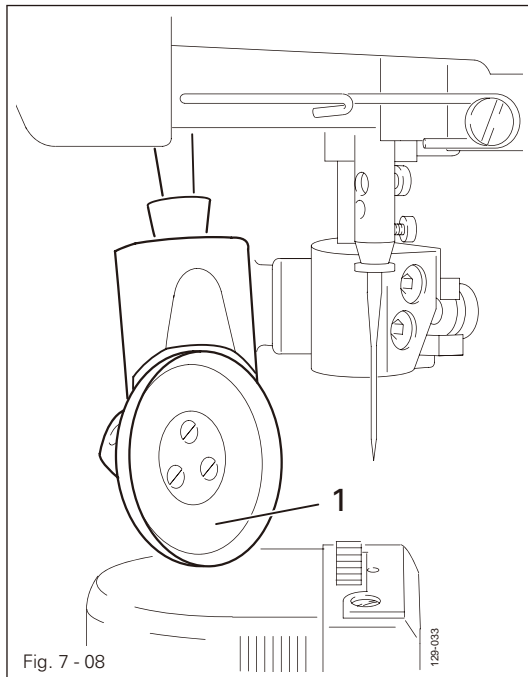
- The roller presser can be raised by pressing the knee lever 1 in the direction of the arrow.

7.07 Key for setting stitch length



- The stitch length is set by pressing key 1 and turning the balance wheel (see Chapter 9.07 Setting the stitch length).

7.08 Swing out roller presser



- When the roller presser is raised, it can be swung out by pulling it lightly downwards.

7.09 Edge trimmer -725/04 for 571

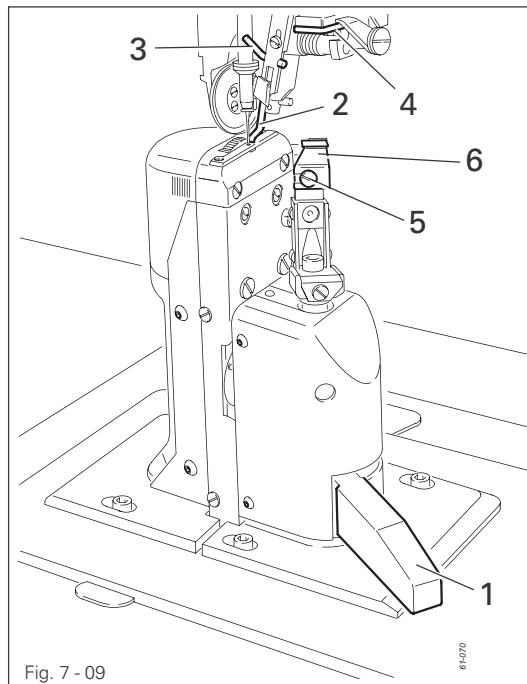


Fig. 7 - 09



Keep your hands away from the moving knife! Danger of injury!

Switch on knife drive:

- Move lever 1 backwards. The knife moves into operating position.

Switch off knife drive:

- Press lever 1. The knife swings backwards.

Switch on edge guide:

- Swing edge guide 2 into position by hand and press lever 3. The edge guide 2 moves into its operating position.

Switch off edge guide:

- Raise edge guide 2 and let it click into position. The edge guide 2 is out of operation.
- Raise lever 4. The edge guide swings backwards.

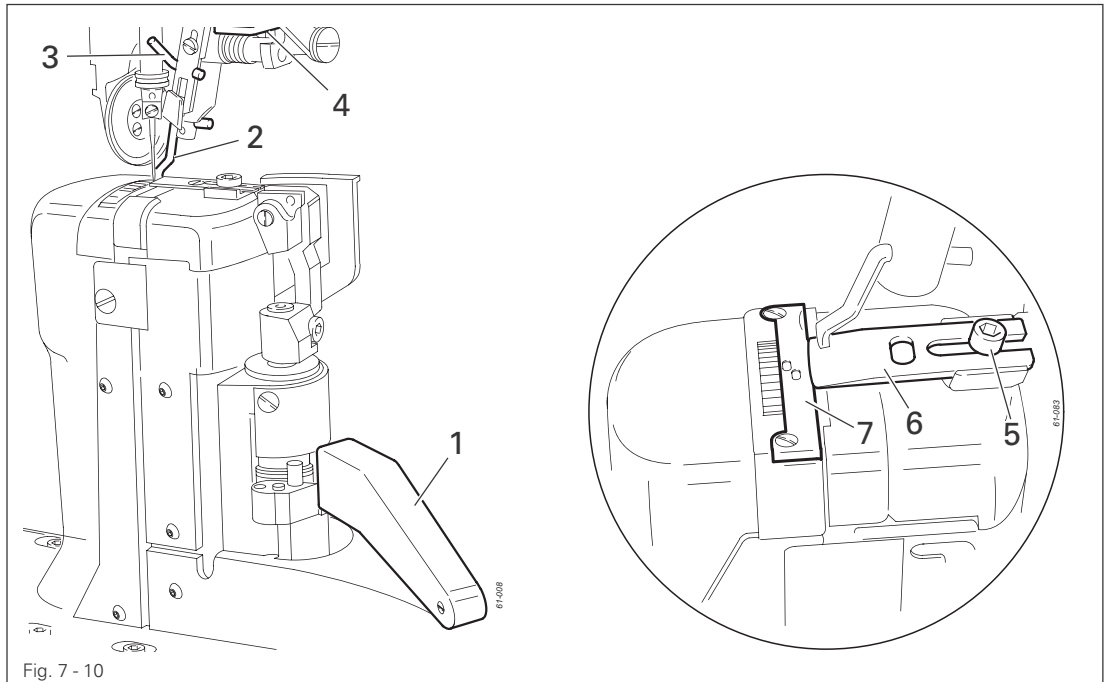
Changing the knife:



The following work may only be carried out by technical staff or by persons who have been properly instructed.

- Switch off the machine.
- Loosen screw 5 and remove knife 6.
- Insert new knife and slightly tighten screw 5.
- Adjust the knife according to Chapter 1.05.05 Cutting stroke in the Adjustment Manual and tighten screw 5.

7.10 Edge trimmer -725/04 for 574 and 591



Keep your hands away from the moving knife! Danger of injury!

Switch on knife drive:

- Move lever 1 backwards. The knife moves into operating position.

Switch off knife drive:

- Press lever 1. The knife swings backwards.

Switch on edge guide:

- Swing edge guide 2 into position by hand and press lever 3. The edge guide 2 moves into its operating position.

Switch off edge guide:

- Raise edge guide 2 and let it click into position. The edge guide 2 is out of operation.
- Raise lever 4. The edge guide swings backwards.

Changing the knife:



The following work may only be carried out by technical staff or by persons who have been properly instructed.

- Switch off the machine.
- Loosen screw 5 and remove knife 6.
- Insert new knife and push it close to needle plate insert 7.
- Slightly tighten screw 5.
- Adjust the knife according to Chapter 1.05.07 Knife position in the Adjustment Manual and tighten screw 5.

7.11 **Control panel** (only on machines with Eco drive or Pico drive)

The description can be found in the separate instruction manual for the control panel.

8 Installation and commissioning



The machine must only be mounted and commissioned by qualified personnel!
All relevant safety regulations are to be observed!

If the machine is delivered without a table, it must be ensured that the frame and the table top which you intend to use can hold the weight of the machine and the motor. It must be ensured that the supporting structure is sufficiently sturdy, including during all sewing operations.

8.01 Installation

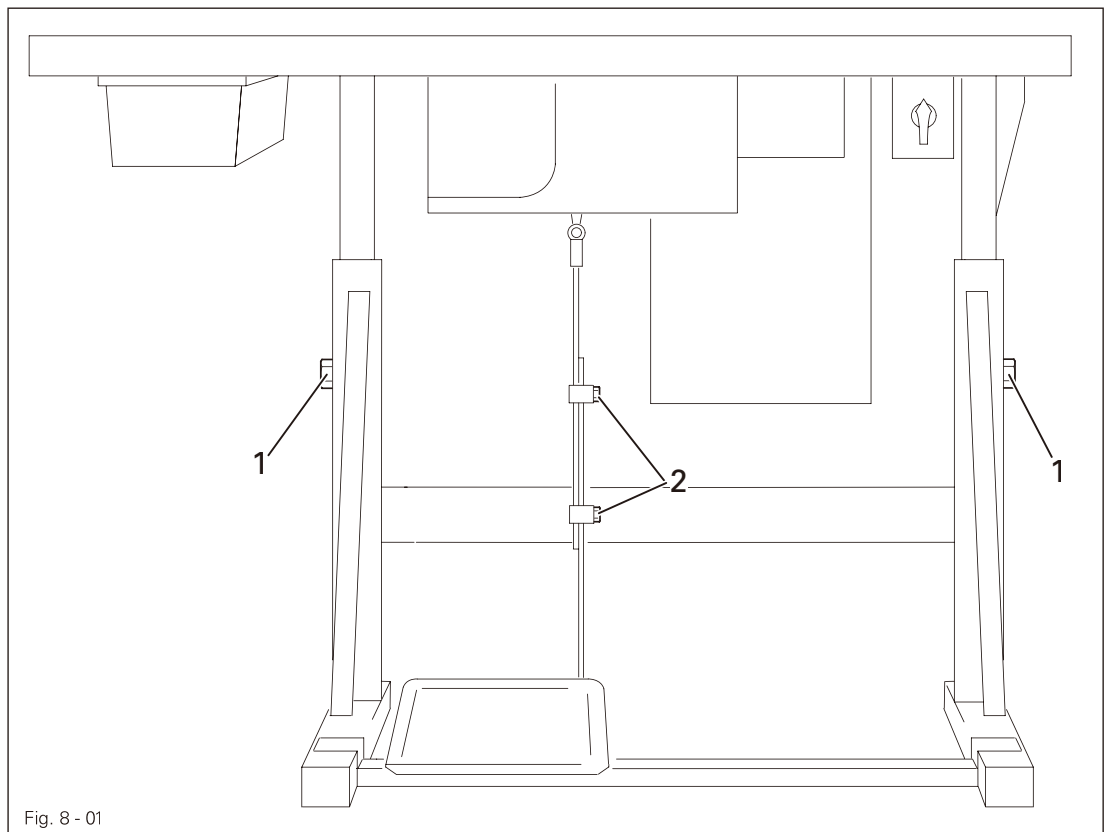
The site where the machine is installed must be provided with suitable connections for the electric current, see Chapter 3 **Specifications**.

It must also be ensured that the standing surface of the machine site is firm and horizontal, and that sufficient lighting is provided.



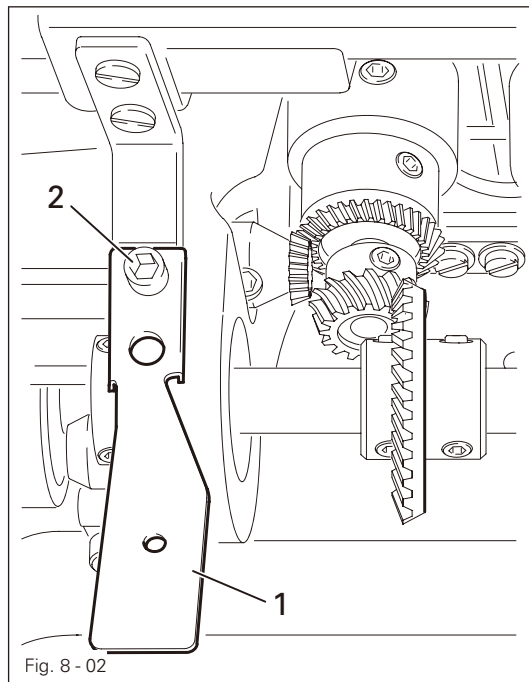
The method of packaging used requires that the table top be lowered for transport. The following is a description of how to adjust the height of the table top.

8.01.01 Adjusting the table-top height



- Loosen screws 1 and 2 and set the desired table-top height
- Tighten screws 1 well.
- Adjust the position of the pedal so that you can operate it comfortably and tighten screw 2.

8.01.02 Fitting the tilt lock



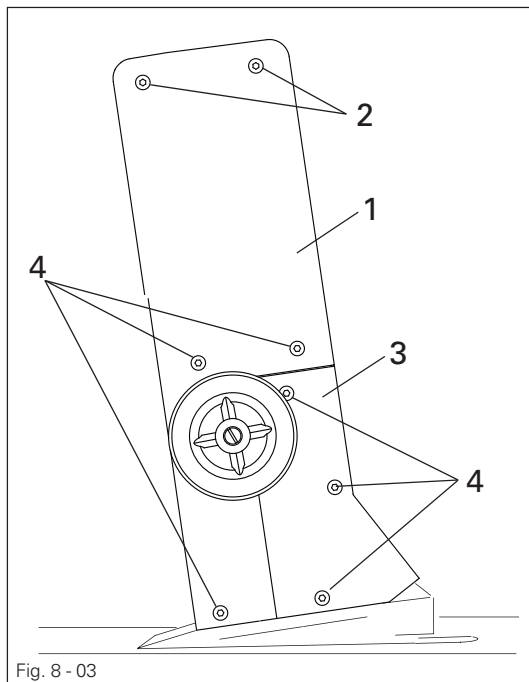
Switch off the machine!
Danger of injury if the machine is started accidentally!

- Screw on the tilt lock 1, provided in the accessories, using screw 2.



Do not operate the machine without tilt lock 1. Danger of crushing between sewing head and table top!

8.01.03 Fitting the machine cover

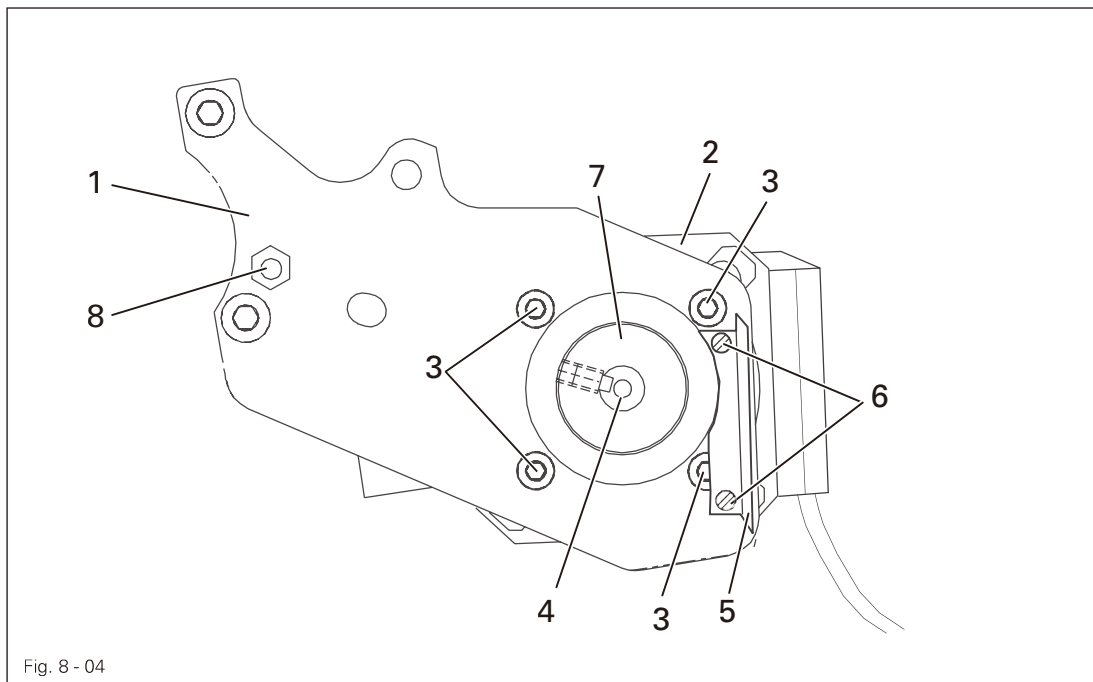


- Use screws 2 (2x) and screws 4 (3x) to fasten cover 1 on the housing.

- Put cover 3 on cover 1 and fasten with screws 4 (3x).

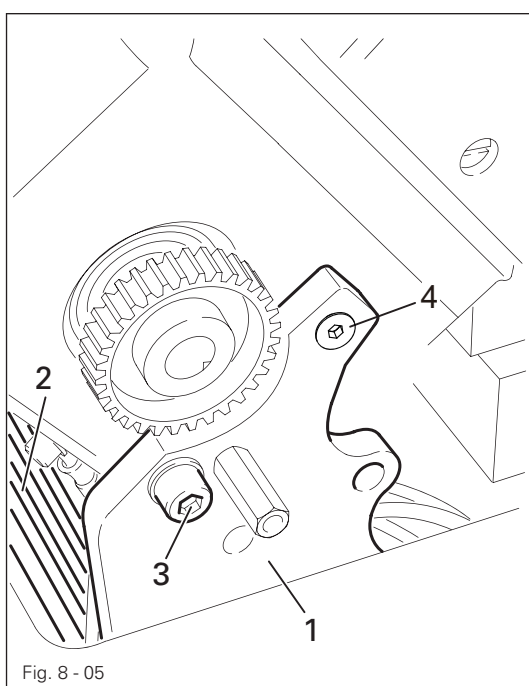
8.02 Mounting the flange motor

8.02.01 Mounting the flange motor to the bearing plate



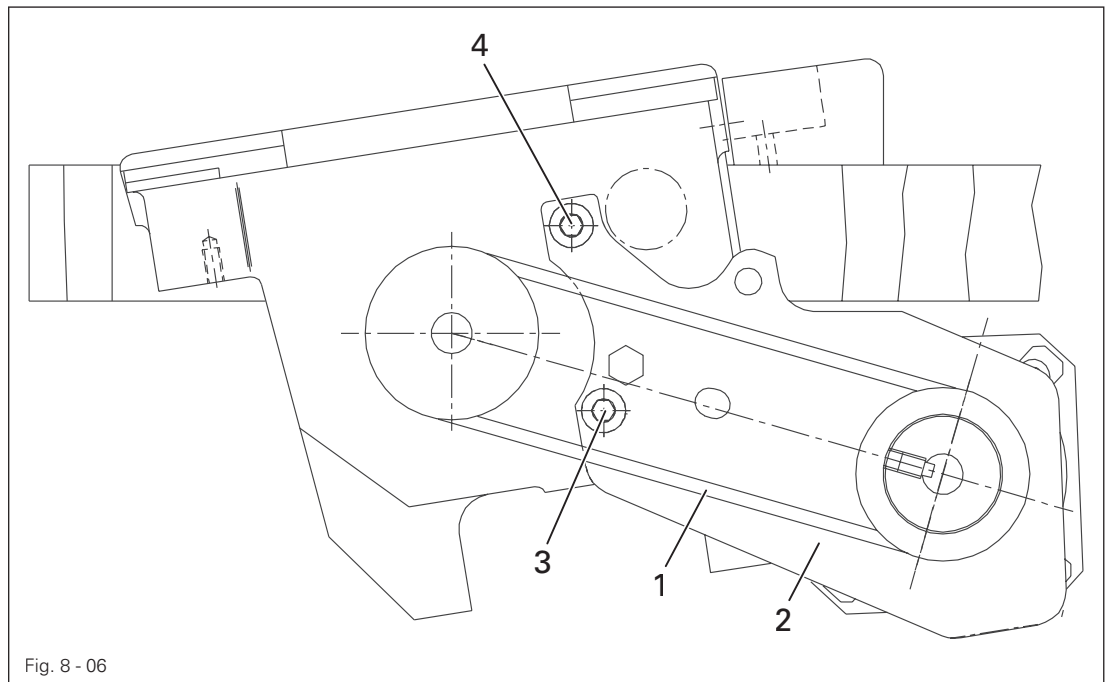
- Attach bearing plate 1 to motor 2 with screws 3 as shown in Fig. 8 - 04.
- Remove the wedge from motor shaft 4.
- Attach angle bracket 5 with screws 6.
- Fit toothed belt wheel 7 to the motor shaft 4, so that the point of the screw is located in the groove of the motor shaft.
- Screw threaded stud 8 into the bearing plate 1.

8.02.02 Mounting the flange motor to the machine



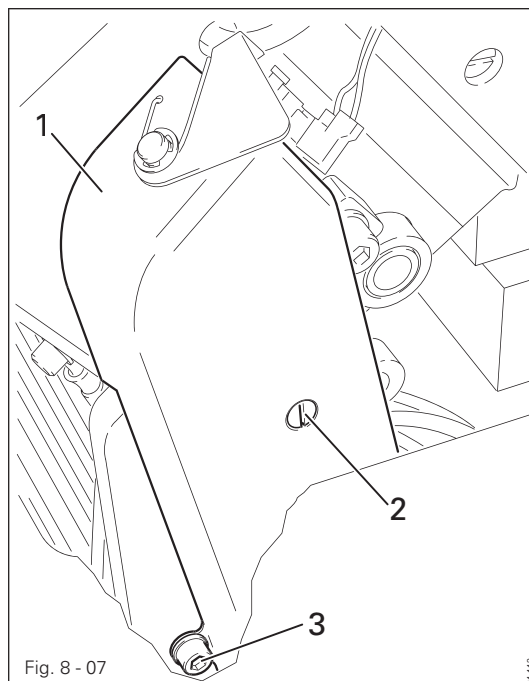
- Attach bearing plate 1 of motor 2 to the machine case with screw 3 and 4 (only tighten screw 3 and 4 slightly).

8.02.03 Mounting the toothed belt and adjusting the tension



- In this position fit toothed belt 1.
- Swing the bearing plate 2 of the motor, so that the toothed belt is tensioned.
- In this position tighten screws 3 and 4.

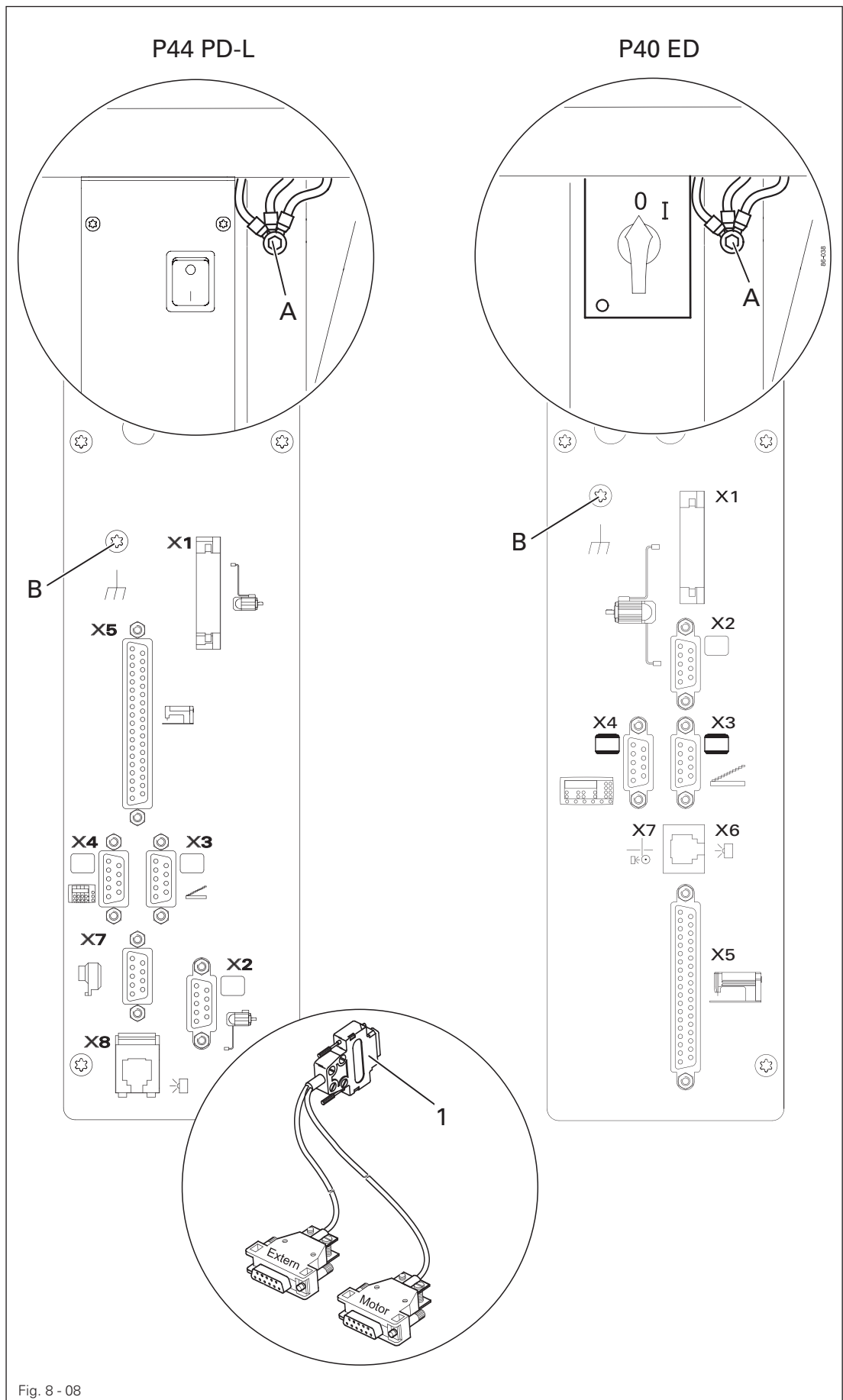
8.02.04 Mounting the belt guard of the flange motor



- Attach belt guard 1 with screws 2 and 3.

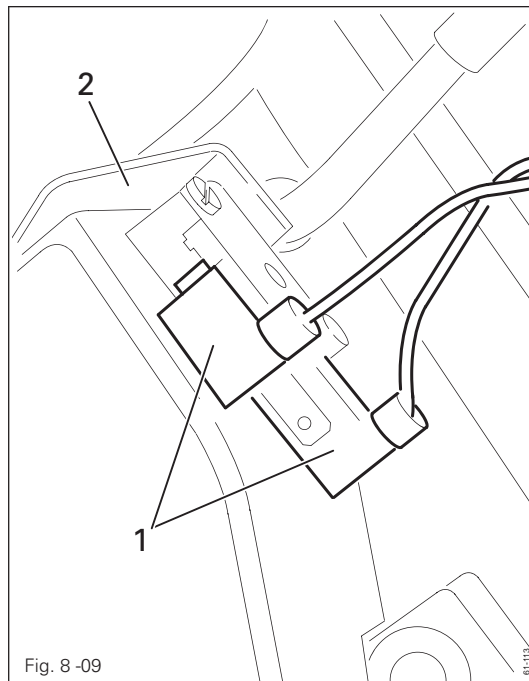


Table top mounting and circuit diagrams (see Chapter 11)



- Connect all plugs as labelled to the control box .
- On the **PFAFF 574** with the control unit **P40 ED** plug **1** of the adapter cable (see blow-up) should be inserted in socket **X2**. The motor and the "external" plug of the synchronizer should be connected to the "motor" plug.
- On the **PFAFF 574** with the control unit **P44 PD-L** the synchronizer plug should be inserted directly in socket **X7**.
- Screw the earth cable from the sewing head and the main switch to earth point **A**.
- Connect earth point **A** to earth point **B** with earth cable.
- Fasten the earth cable from plug **X1** to earth point **B**.

8.04 Connecting the safety switch



- Connect plug **1** of safety switch **2** as shown in Fig. 8-09.

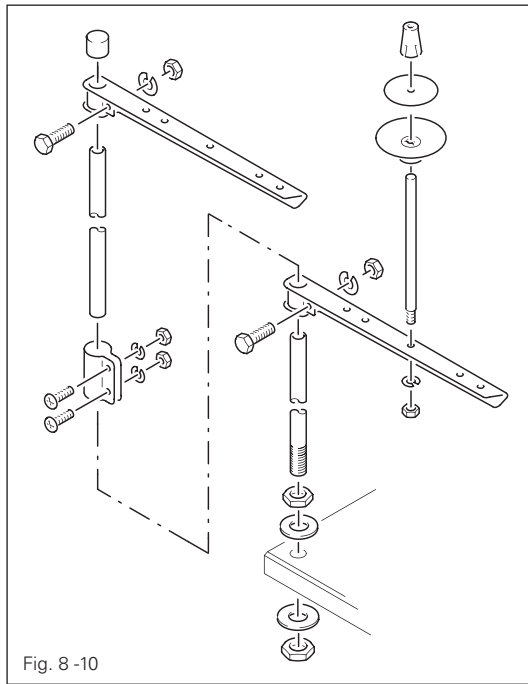


When the sewing head is tilted back, the safety switch prevents the machine starting when the main switch is on.

8.05 Checking the start inhibitor function

- Switch the machine on at the main switch and tilt back the sewing head.
- The error message "Error 9" must appear on the control panel.
- If the message does not appear, check the setting of safety switch **2**.
- After the sewing head has been returned to the upright position, the machine is ready for operation again.

8.06 Fitting the reel stand



- Fit the reel stand as shown in Fig. 8-10.
- Afterwards insert the stand in the hole in the table top and secure it with the nuts provided.

8.07 Commissioning

- Check the machine, particularly the electrical wiring, for any damage.
- Clean the machine thoroughly and then oil it or fill in oil (see Chapter 10 Care and maintenance).
- Have a mechanic check whether the motor of the machine can be operated with the available power supply, and that the motor is correctly connected in the junction box.



If there are any discrepancies the machine must not be operated under any circumstances.



Before starting up the machine for the first time, have specialists check whether parameter 799 (machine class) is set at "2, 4" or "6" depending on the control unit, and parameter 800 (sewing direction) is set at "1" (see Chapter 8.09 Basic position of the machine drive unit). On machines with PicoDrive and control unit P44 PD-L it is also necessary to check whether parameter 802 on the 571 and 591 are set at "0", and on the 574 at "1". If necessary, have these adjustments made.



The machine may only be connected to an earthed socket!

8.08 Switching the machine on/off

- Switch the machine on or off (see Chapter 7.01 On/off switch).

8.09 Basic position of the machine drive unit

8.09.01 On machines with EcoDrive and control unit P40 ED

- Switch on the machine.
- Press the **TE/speed key** twice to select the input mode.
- Select parameter "798" by pressing the corresponding +/- key, and select service level C, see Chapter **Selecting the user level** in the instruction manual for the control panel.
- By pressing the corresponding +/- key select the parameter "799" (Selecting the machine class).
- Check whether value "2" is set, and correct it if necessary.



If the parameter has to be altered, operate the **TE/Speed** key and then switch off the machine and switch it on again. Then select service level **C** again as described above.

- By pressing the corresponding +/- key, select parameter "800" (selecting the sewing direction).
- By pressing the corresponding +/- key, select the value for the parameter at "1".
- By pressing the corresponding +/- key, select parameter "700".
- Sew a stitch by operating the pedal.
- Turn the balance wheel in the sewing direction until the descending needle is level with the top edge of the needle plate.
- Then check the parameter values listed in the parameter list (see Chapter **10.07 Parameter Settings**) and adjust them if necessary.
- Conclude the adjustment of the sewing motor by pressing the **TE/Speed key**.

8.09.02 On machines with PicoDrive and control unit P44 PD-L

- Switch on the machine.
- Call up the parameter input by pressing the "scroll" key.
- To switch the function keys to input (LED in the **TE** key lights up), press the **TE** key.
- By pressing the corresponding +/- keys, select parameter "798" and service level **C**, see Chapter **Selecting the User Level** in the separate Control Panel Instruction Manual.
- Select parameter "799" by pressing the corresponding +/- keys.
- Check whether the value on the **571** and **591** is set at "4" and on the **574** at "6" and alter if necessary.
- Switch the machine off and then on again.
- Select parameter "800" by pressing the corresponding +/- keys.
- Check whether the value is set at "1" (balance wheel turns towards the operator) and alter if necessary.
- Select parameter "802" by pressing the corresponding +/- keys.
- Check whether the value is set at "0" on the **571** and **591** (= no gear reduction) and at "1" on the **574** (= gear reduction), alter if necessary.
- By pressing the corresponding +/- key, select parameter "700"
- Sew a stitch by operating the pedal.
- Turn the balance wheel in the sewing direction until the descending needle is level with the top edge of the needle plate.
- Then check the parameter values listed in the parameter list (see Chapter **10.07 Parameter Settings**) and adjust them if necessary.
- Conclude the adjustment of the sewing motor by pressing the **TE/Speed** key.

9

Setting up



All instructions and regulations in this instruction manual must be observed. Special attention must be paid to all safety regulations!



All setting-up work must only be carried out by personnel with the appropriate training. For all setting-up work the machine must be disconnected from its power supply by turning off the on/off switch, or removing the plug from the electric power socket.

9.01

Inserting the needle

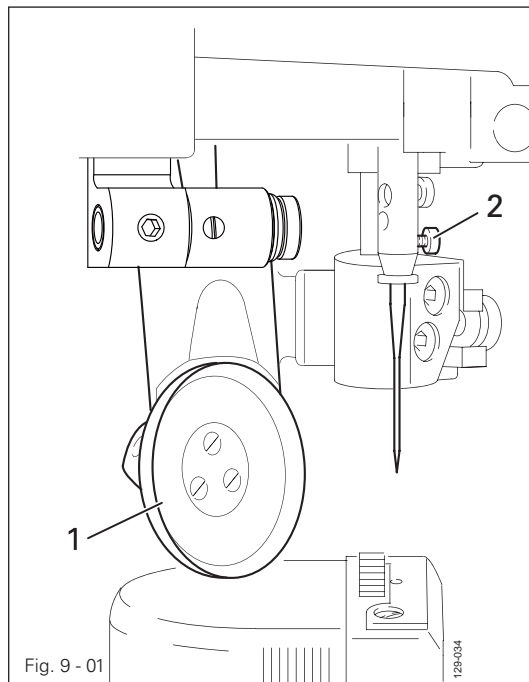


Fig. 9 - 01

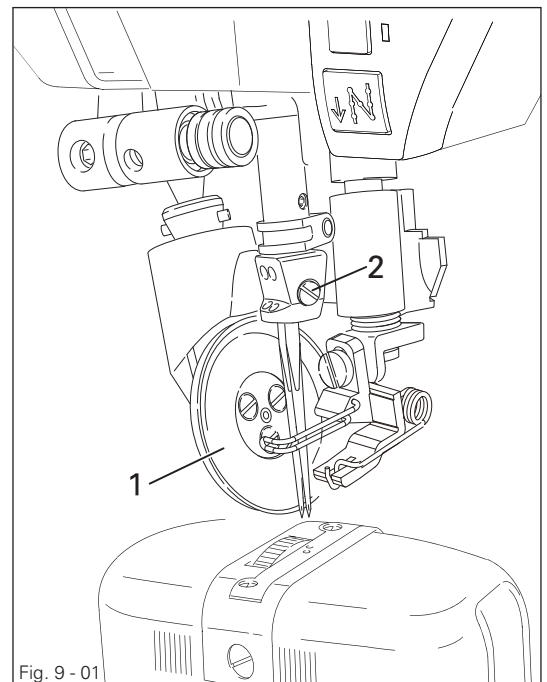


Fig. 9 - 01



Switch off the machine!
Danger of injury due to unintentional starting of the machine!



Only use needles from the system intended for the machine, see Chapter 3 Specifications.

PFAFF 571 and 591

- Raise the roller presser 1 and swing it out..
- Loosen screw 2 and insert the needle as far as possible. The long groove must **face to the right** on model 571 and to **the left** on model 591.
- Tighten screw 2 and swing roller presser 1 back into position.

PFAFF 574

- Raise the roller presser 1 and swing it out.
- Loosen screws 2 and insert the needles so that the long groove of the left needle is **facing right**, and that of the right needle is **facing left**.
- Tighten screws 2 and swing roller presser 1 back into position.

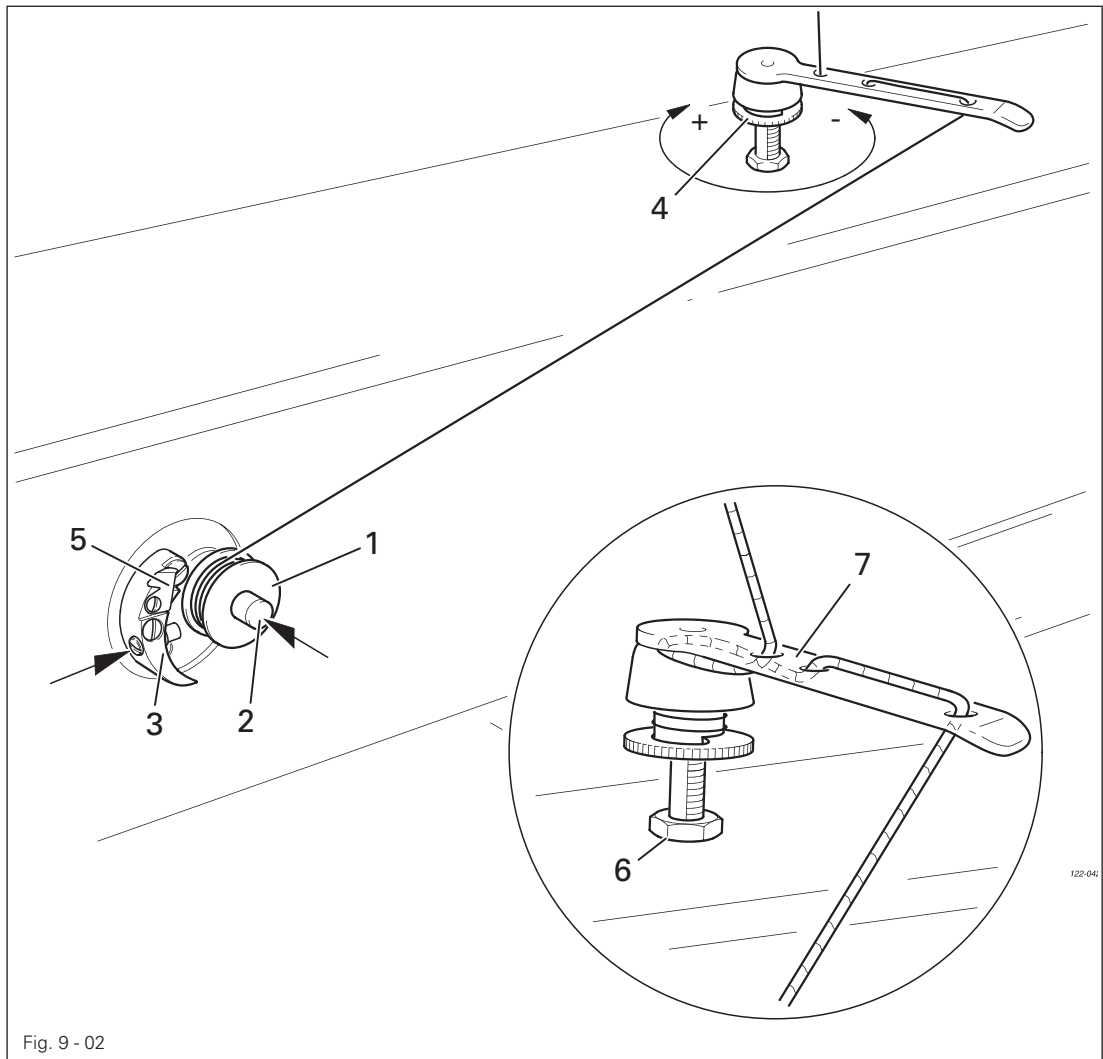


Fig. 9 - 02

- Place an empty bobbin 1 onto bobbin shaft 2.
- Thread the bobbin in accordance with Fig. 9-02 and wind it anti-clockwise around bobbin 1 a few times.
- Switch on the bobbin winder while at the same time pressing bobbin winder spindle 2 and lever 3.



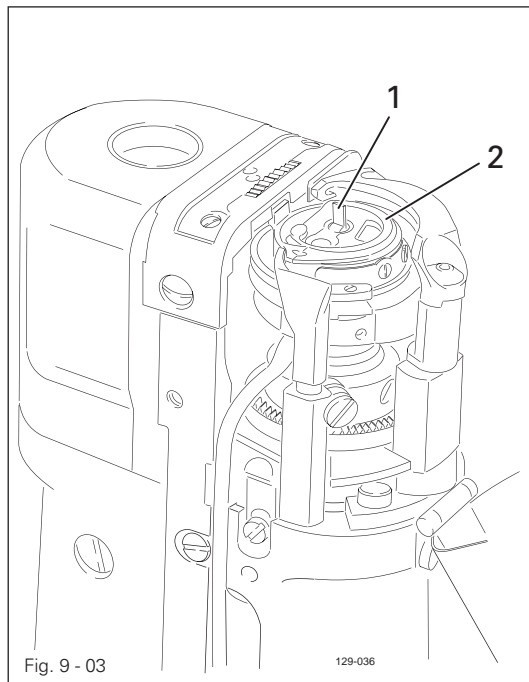
The bobbin fills up during sewing.

- The tension of the thread on bobbin 1 can be adjusted with knurled screw 4.
- The bobbin winder stops automatically when bobbin 1 is full.
- Remove the filled bobbin 1 and cut the thread on knife 5.



If the thread is wound unevenly, loosen nut 6 and turn thread guide 7 accordingly. Retighten nut 6 after the adjustment.

9.03 Removing/Inserting the bobbin case



Switch the machine off!
 Danger of injury if the machine is started accidentally!

Removing the bobbin case:

- Open the post cap.
- Raise latch 1 and remove bobbin case 2.

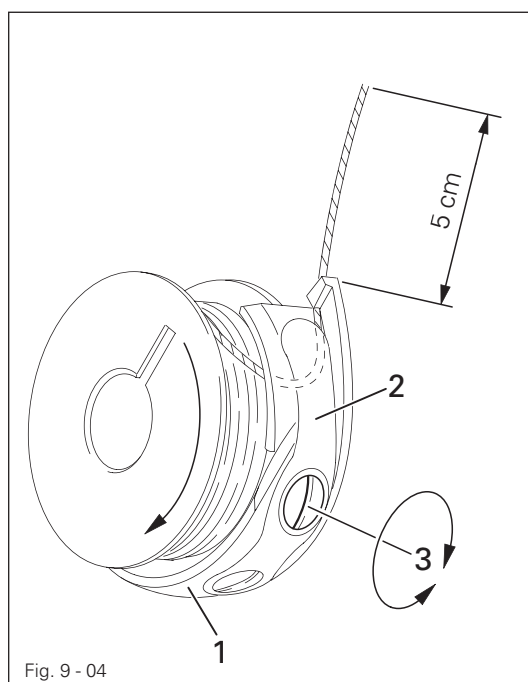
Inserting the bobbin case:

- Insert bobbin case 2.
- Close the latch and close the post cap.



574 is shown in Fig. 9 - 03.

9.04 Threading the bobbin case/Adjusting the bobbin thread tension



- Insert the bobbin into the bobbin case 1.
- Pass the thread through the slot under spring 2.
- Pass the thread through the notch.
- Adjust the thread tension by turning screw 3.



When the thread is pulled, the bobbin must rotate in the direction of the arrow.

9.05 Threading the needle thread and regulating its tension on model 571 and 591

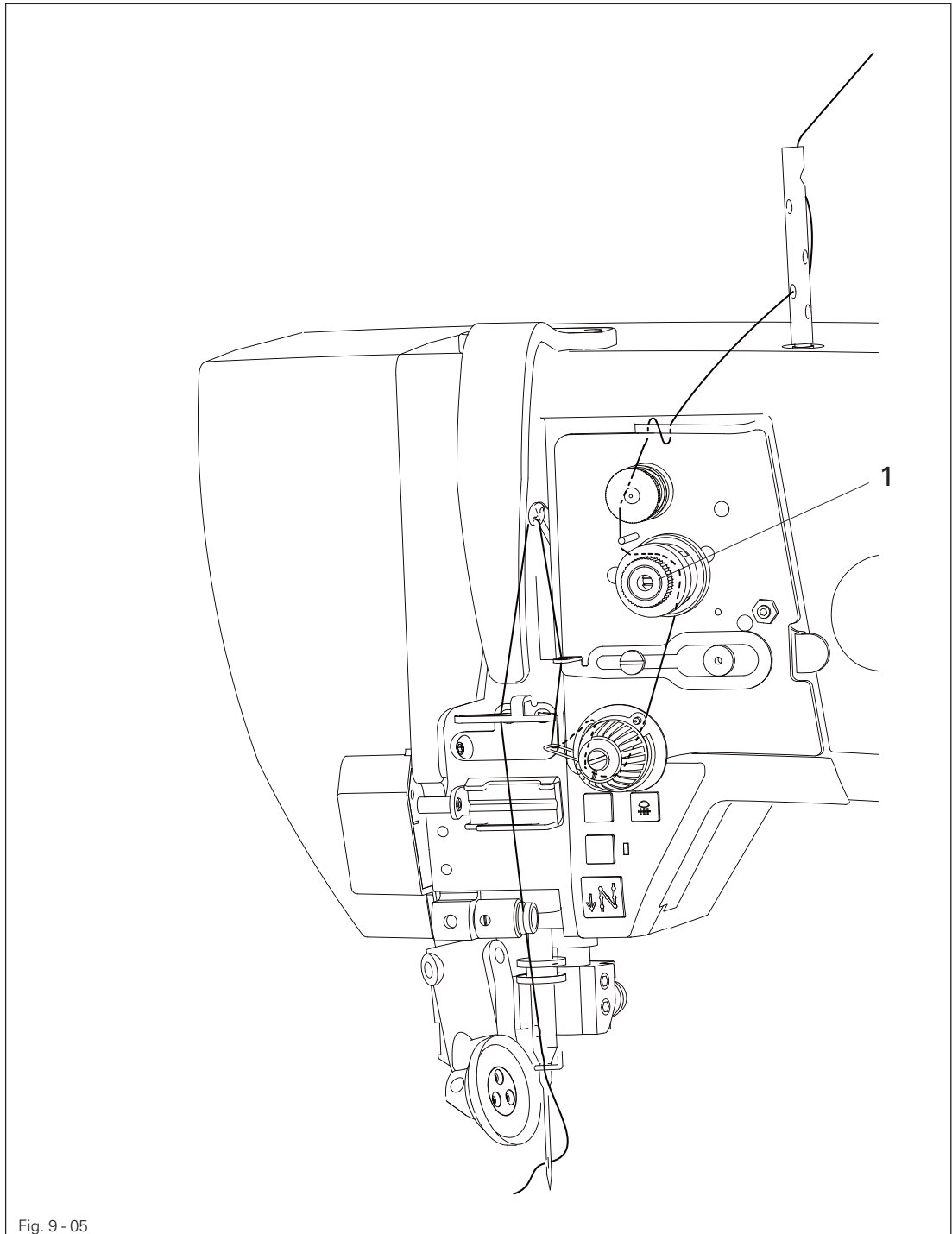


Fig. 9 - 05



Switch the machine off!
Danger of injury if the machine is started accidentally!

- Thread the needle thread as shown in Fig. 9-05.
- On model **571** the needle is threaded from the **right to the left**, and on model **591** from the **left to the right**.
- Adjust the needle thread tension by turning milled screw **1**.

9.06 Threading the needle thread and regulating its tension on model 574

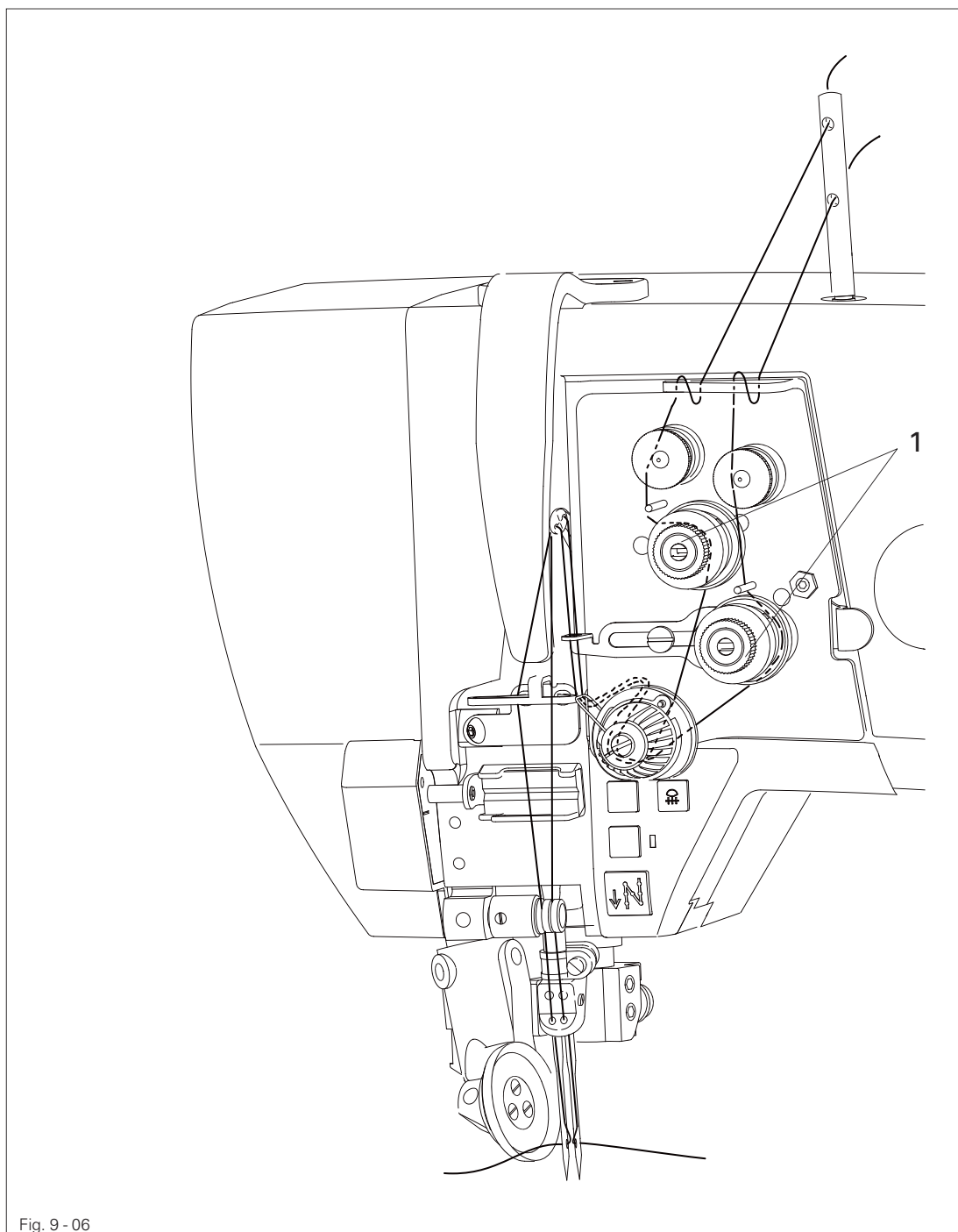


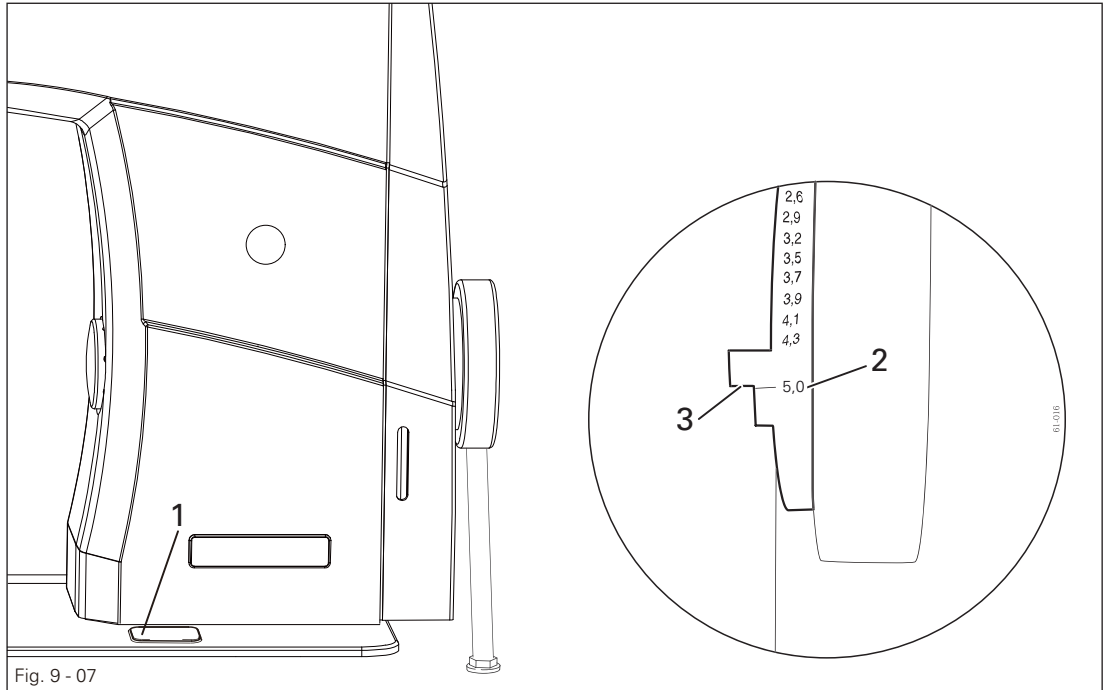
Fig. 9 - 06



Switch the machine off!
 Danger of injury if the machine is started accidentally!

- Thread both needle threads as shown in Fig. 9-06.
- The left needle is threaded from the **right to the left**, and the right needle from the **left to the right**.
- Adjust the needle thread tensions by turning milled screws 1.

9.07 Setting the stitch length



- Press key 1 and at the same time turn the balance wheel until the stitch setter clicks into position.
- Hold down key 1 and turn the balance wheel to and front until the stitch length required is shown on the scale 2 opposite the bottom edge 3 of the belt guard recess.

9.08 Adjusting the stitch counter for the bobbin thread control

(only on machines with Motor and P40 (ED) control unit)

Please see the description in the separate control panel instruction manual.

10 Care and maintenance

10.01 Servicing and maintenance intervals

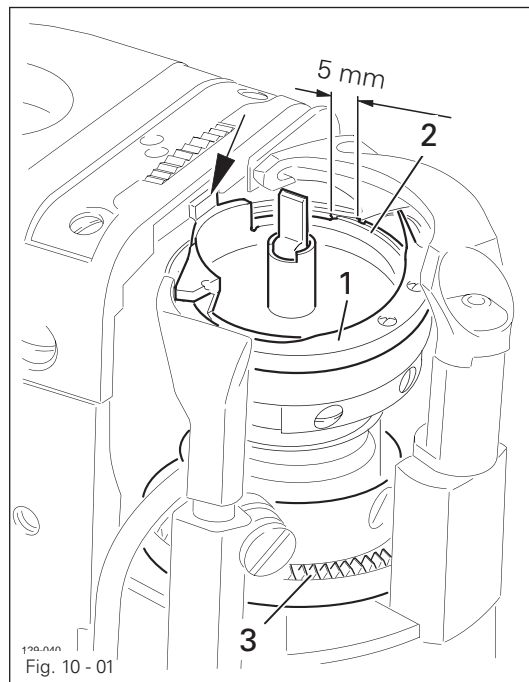
Clean	daily, more frequently if in continuous operation
Oil level (thread lubrication/hook lubrication).....	daily, before use
Oil the hook.....	daily, before use
Lubricate the bevel gears.....	once a year



These maintenance intervals are calculated for the average running time of a single shift operation. If the machine is operated more than this, shorter intervals are recommended.

10.02 Cleaning

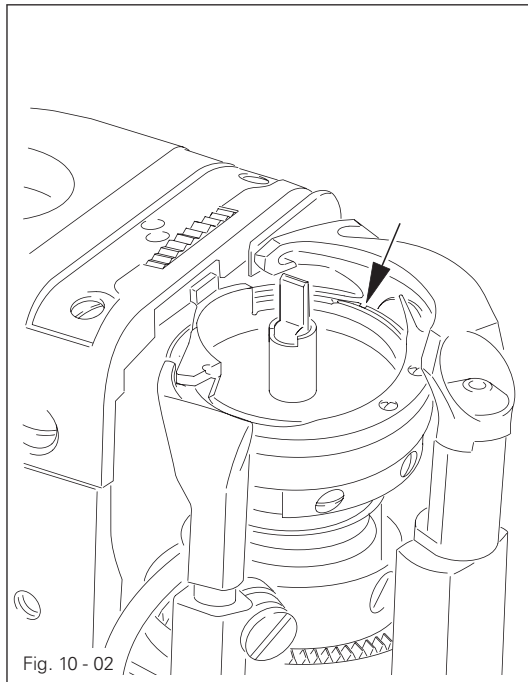
Clean the hook, hook compartment and toothed wheel **3** daily, several times if in continuous use.



Switch the machine off!
Danger of injury if the machine is started accidentally!

- Bring the needle bar to its highest position.
- Open the post cap and remove the bobbin case cap and the bobbin.
- Unscrew hook gib **1**.
- Turn the handwheel until the point of bobbin case **2** penetrates into the groove of the hook race approx. **5 mm**.
- Remove bobbin case **2**.
- Clean the hook race with paraffin.
- When inserting the bobbin case **2**, ensure that the horn of the bobbin case **2** engages in the groove of the needle plate.
- Screw hook gib **1** back on and close the post cap.

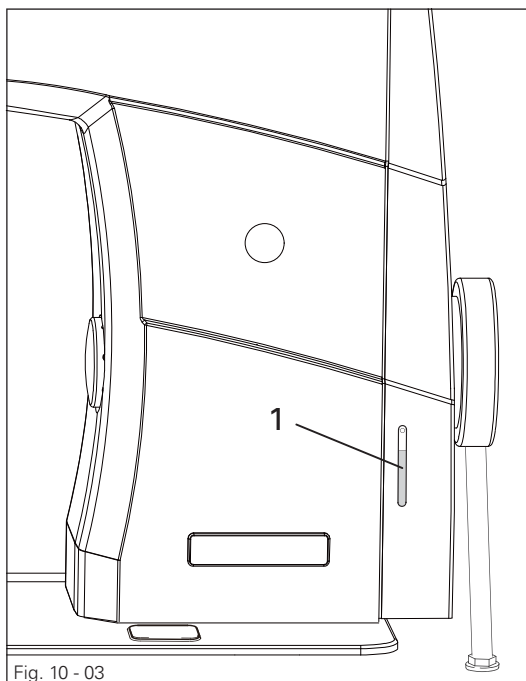
10.03 Oiling the hook



Switch the machine off!
Danger of injury if the machine is started accidentally!

- Before commissioning the machine, and after long periods out of operation, pour a few drops of oil into the hook race (see arrow).

10.04 Oil bowl for hook lubrication



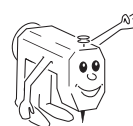
Check the oil level before each use.

There must always be oil in reservoir 1.

- If required refill oil through hole.



Use only oil with a mean viscosity of $22.0 \text{ mm}^2/\text{s}$ at 40°C and a density of 0.865 g/cm^3 at 15°C .



We recommend PFAFF sewing machine oil order-no. 280-1-120 144.

10.05 Lubricating the bevel gears

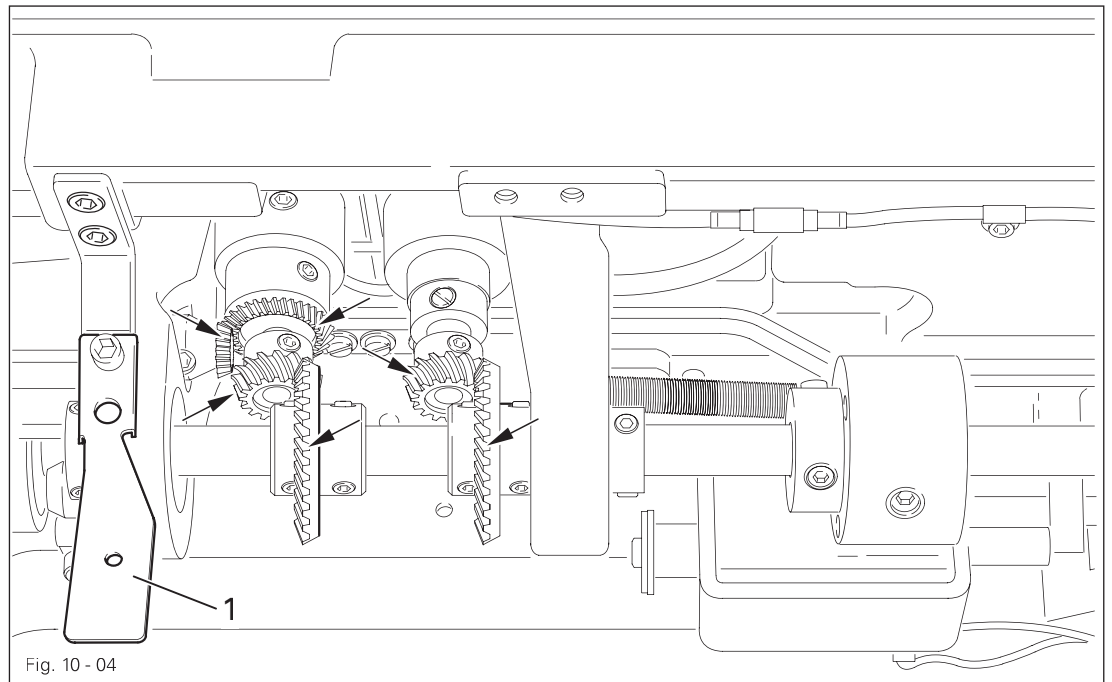


Fig. 10 - 04



Switch the machine off!
Danger of injury if the machine is started accidentally!

- All bevel gears must be supplied with new grease once a year.
- Tilt the sewing head back onto the support.

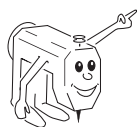


Fig. 10-04 shows the bevel gears of the 574.

- To set the sewing head upright, press tilt lock 1 backwards and set the sewing head upright using both hands.

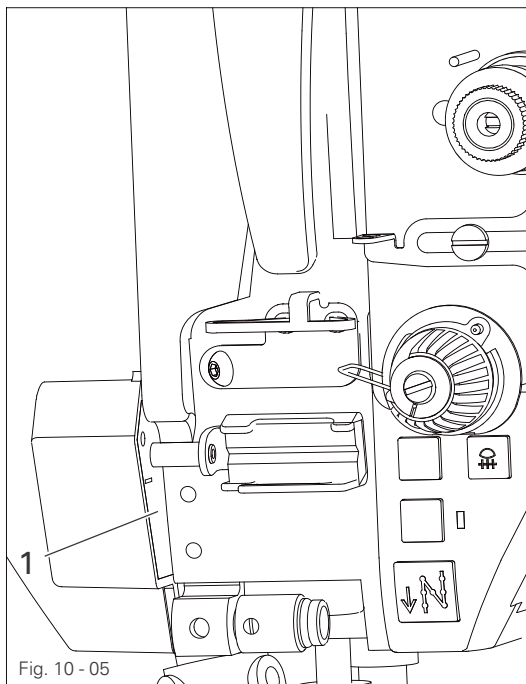


Use both hands to set the sewing head upright!
Danger of crushing between the sewing head and the table top!



We recommend PFAFF sodium grease with a dripping point of approx. 150° C,
Order No. 280-1-120 243.

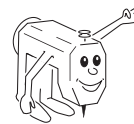
10.06 Filling the oil reservoir of the thread lubrication unit



Check the oil level before each use.

There must always be oil in reservoir 1.

- If required refill oil through hole.



We recommend PFAFF thread lubricating oil, Order No. 280-1-120 217.

10.07 Parameter settings

(only on machines with EcoDrive and control unit P40ED or PicoDrive and control unit P44 PD-L)

- The selection of the user level and the alteration of parameters is described in the separate instruction manual for the drive unit.

10.07.01 Parameter list

Gruppe	Parameter	Description	User lever	Setting range	Set value P40 ED	Set value P44 PD-L
1	105	Speed for start backtackl	B, C B, C	100 - 2000 300 - 2000	700	700
	110	Speed for end backtack	B, C B, C	100 - 2000 300 - 2000	700	700
5	523	Tack ON ...= ornamental tack (stitch-in-stitch) OFF = standard tack	A, B, C	ON - OFF	ON	ON
6	605	Drehzahlanzeige ON = on OFF = out	B, C	ON - OFF	OFF	OFF

▲ See Chapter 3 Specifications

* Adjustment see Chapter 8.09 Basic position of the machine drive unit.

Gruppe	Parameter	Description	User lever	Setting range	Set value P40 ED	Set value P44 PD-L
6	606	Speed min.	B, C B, C	60 - 650 120 - 800	180	180
	607	Speed max.	B, C	300 - 3200	▲	▲
	609	Cutting speed 1	B, C B, C	60 - 300 100 - 700	180	180
	660	Bobbin thread control 0 = off, 1 = thread monitor, 2 = reverse counter	A, B, C	0 - 2	0	
7	700	Needle position 0 (needle reference position)	B, C	0 -255	*	*
	702	Needle position 1 (needle lowered)	B, C	0 -255	15	15
	703	Needle position 2 (take-up lever raised)	B, C	0 -255	230	571 224 574 230 591 224
	705	Needle position 5 (end cutting signal 1)	B, C	0 - 255	200	100
	706	Needle position 6 (start cutting signal 2)	B, C	0 - 255	15	17
	707	Needle position 9 (start thread tension release/start thread catcher)	B, C	0 - 255	195	195
	760	Multiplier for the fixed value (200) stitch count	A,B,C	0 - 250	5	
	798	User level 0 = User level 1 = Technician level 11 = Service level	A,B,C	0 - 20	0	0
	799	Selected machine class	C	P40 1 - 8 P44 1 - 7	2	◆
8	800	Rotating direction of the motor	C	0 - 1	1	1
	802	Main drive reduction ratio 0 = 1:1 1 = variable	C	0 - 1		571 0 574 1 591 0

◆ = On the PFAFF 574 the machine class 6 and on the PFAFF 571 and 591 the machine class 4 must be entered.

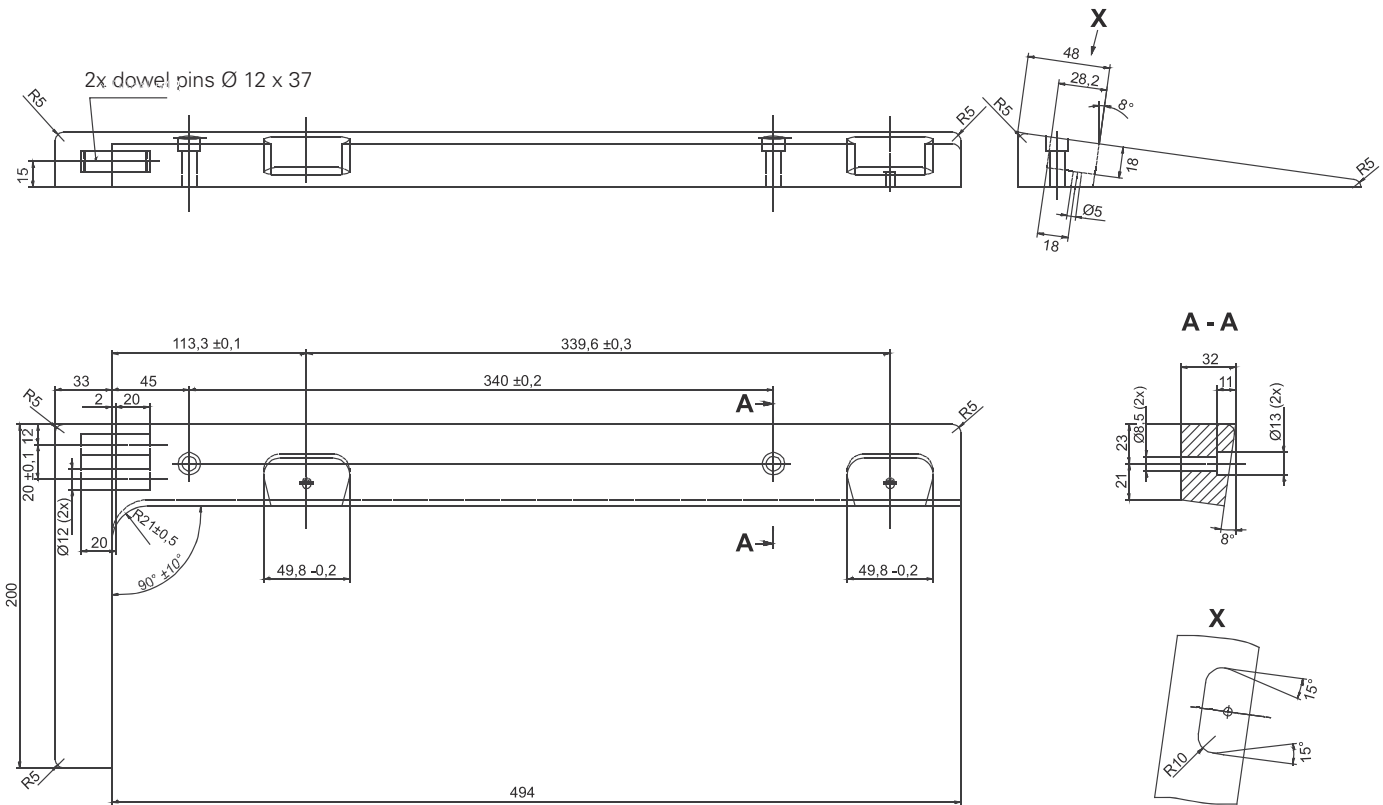


Further parameters and the description for an internet update of the machine software and reset /cold start of the machine can be found in the instruction manual for the control panel.

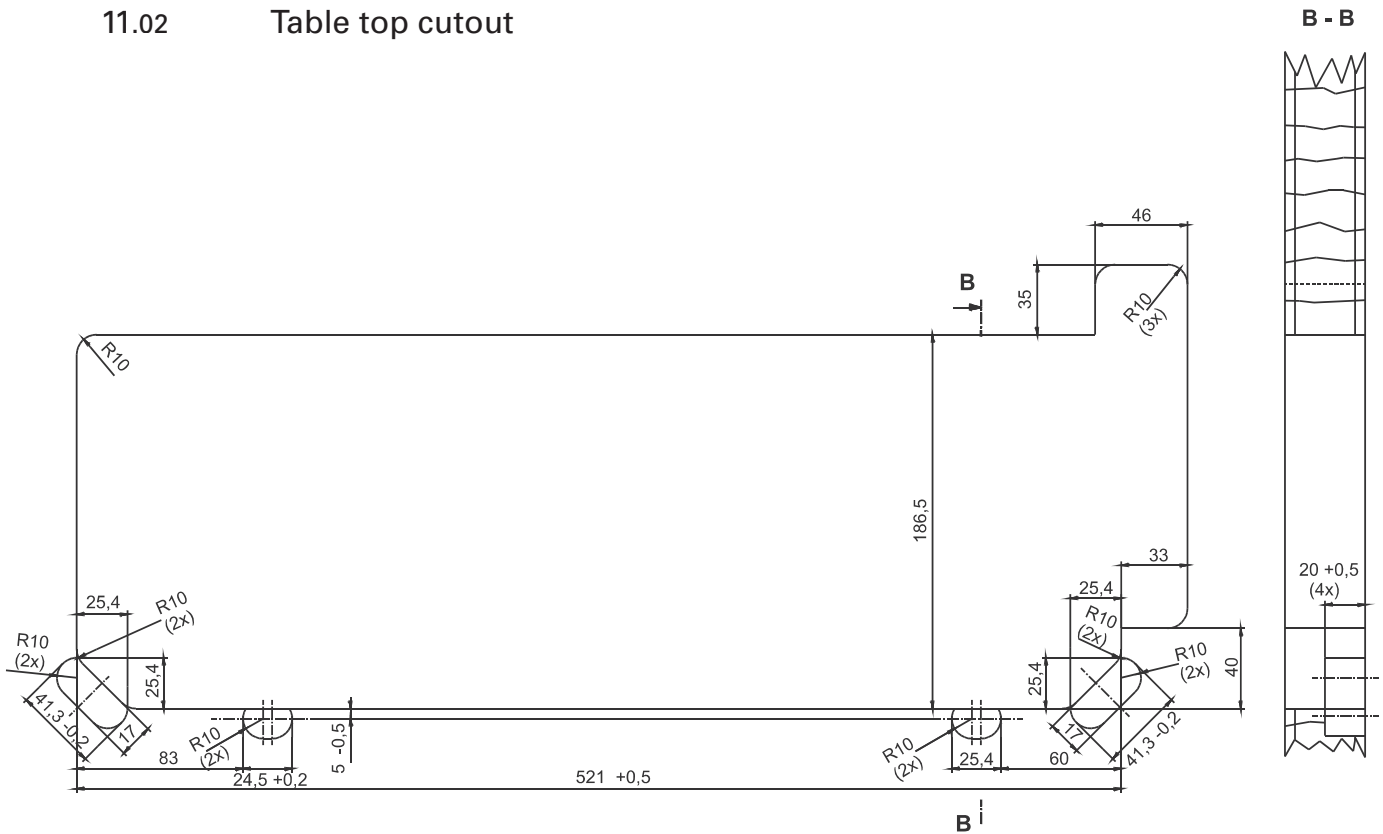
Mounting the table top

11 Mounting the table top

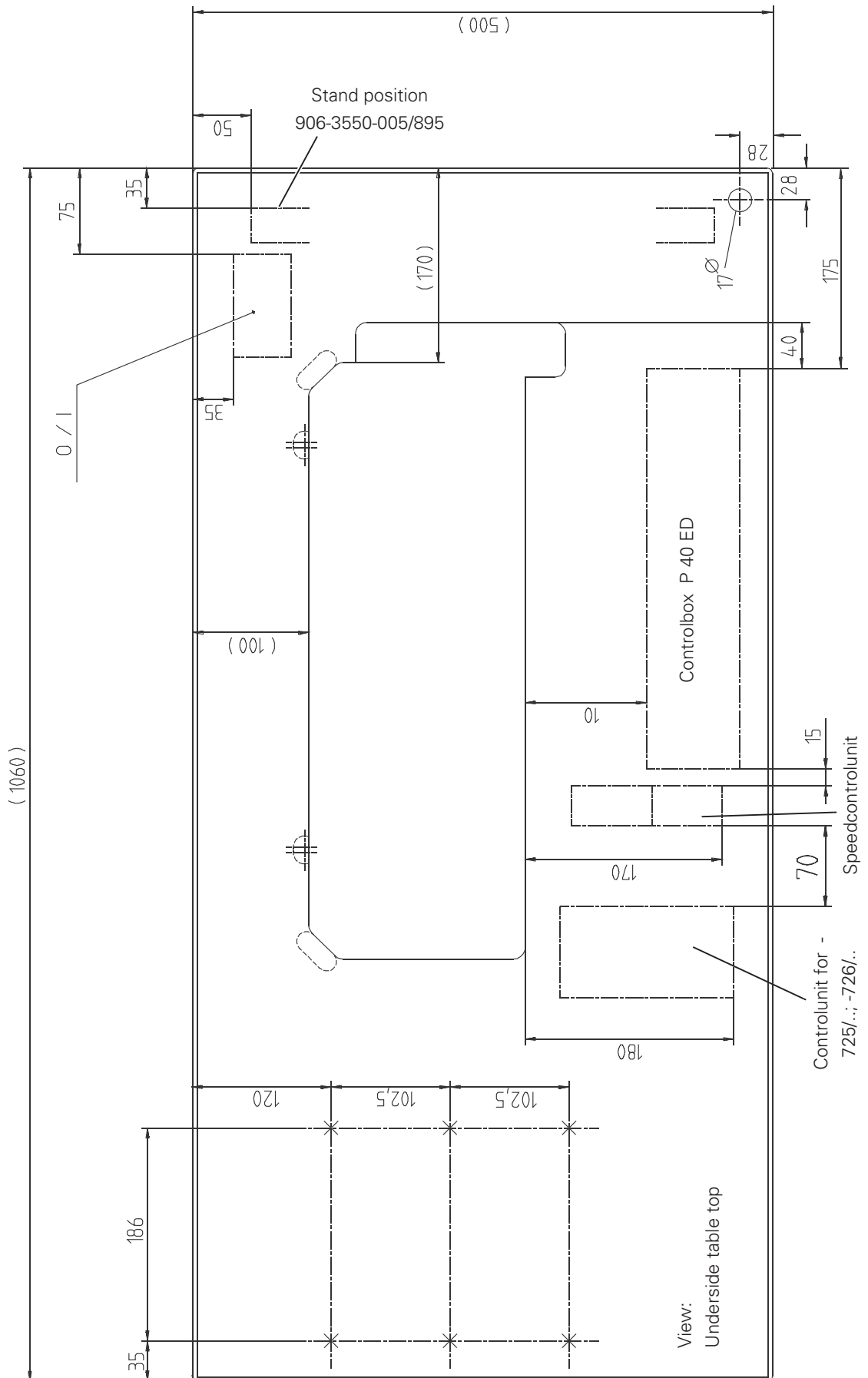
11.01 Tilted work base



11.02 Table top cutout

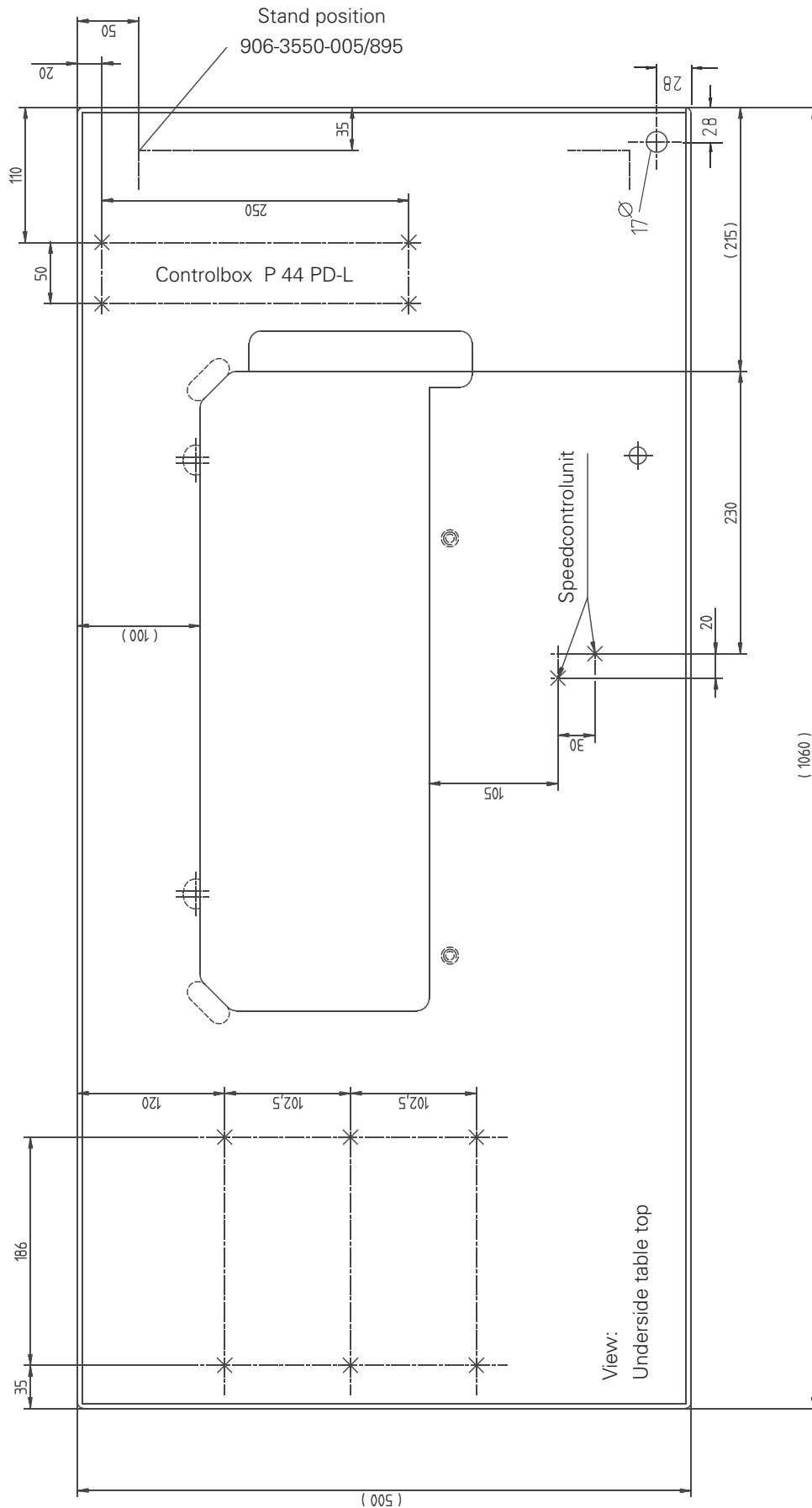


11.03 Mounting the table top (with EcoDrive and control unit P 40 ED)



Mounting the table top

11.04 Mounting the table top (with PicoDrive and control unit P44 PD-L)



11.05 Circuit diagrams

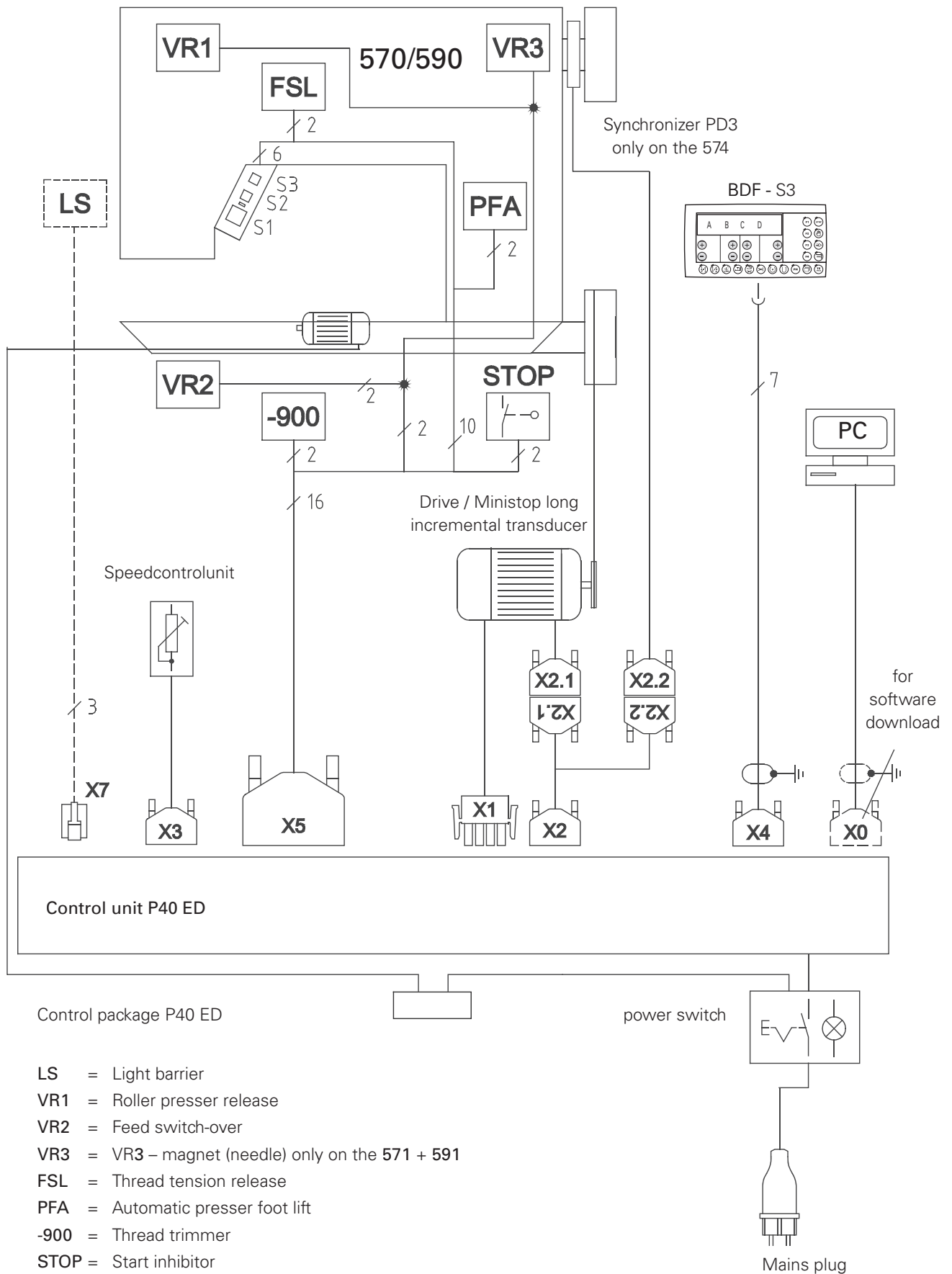
11.05.01 Reference list for the Circuit diagrams 91-191 524-95 and 91-191 534-95

Control package		
	P40 ED	P44 PD-L
	91-191 524-95	91-191 534-95
A1	Control unit P40E	Control unit P44PD
A2	BDF-S3 control panel	PicoTop control panel
A14	Sewing head recognition(O TE)	-
C1	Start capacitor	-
H1	Sewing lamp	
H10	LED reverse stitch counting	-
HQ1	-	Control lamp main switch
K1	Knife motor relay	-
M1	Sewing motor with incremental transmitter	
M10	Knife motor	-
PD3	Externer Positionsgeber PD3 (574)	
Q1	Hauptschalter	
R1	-	LED series resistor
S1	Pedal (speed control unit)	
S10	Knife motor key	-
S41	Manual backtacking key	
S42	Needle position change / threading key	
S43	Single stitch key	
S46	Start inhibitor switch	
T10	Knife motor transformer	-
X0	RS 232 interface (PC) plug	-
X1	Sewing motor plug	
X2	Incremental transmitter plug	
X2.1	Incremental transmitter plug	-
X2.2	Synchronizer PD3 plug	-
X3	Pedal (speed control unit) plug	
X4	BDF-S3 control panel plug	PicoTop control panel plug / RS232 (PC)
X5	Outputs/inputs plug	
X6	Bobbin thread monitor plug (optional)	-
X7	Light barrier plug (optional)	Synchronizer PD3 plug
X8	-	Light barrier plug (optional)
X22	Thread trimmer plug(-900/..)	
X24	Automatic presser foot lift plug (-910/..)	
X25.0	Backtacking device plug (-911/..)	
X25.1	Backtacking device plug (-911/..) - roller presser	
X25.2	Backtacking device plug (-911/..) - feed wheel	
X25.3	Backtacking device plug (-911/..) - needle	

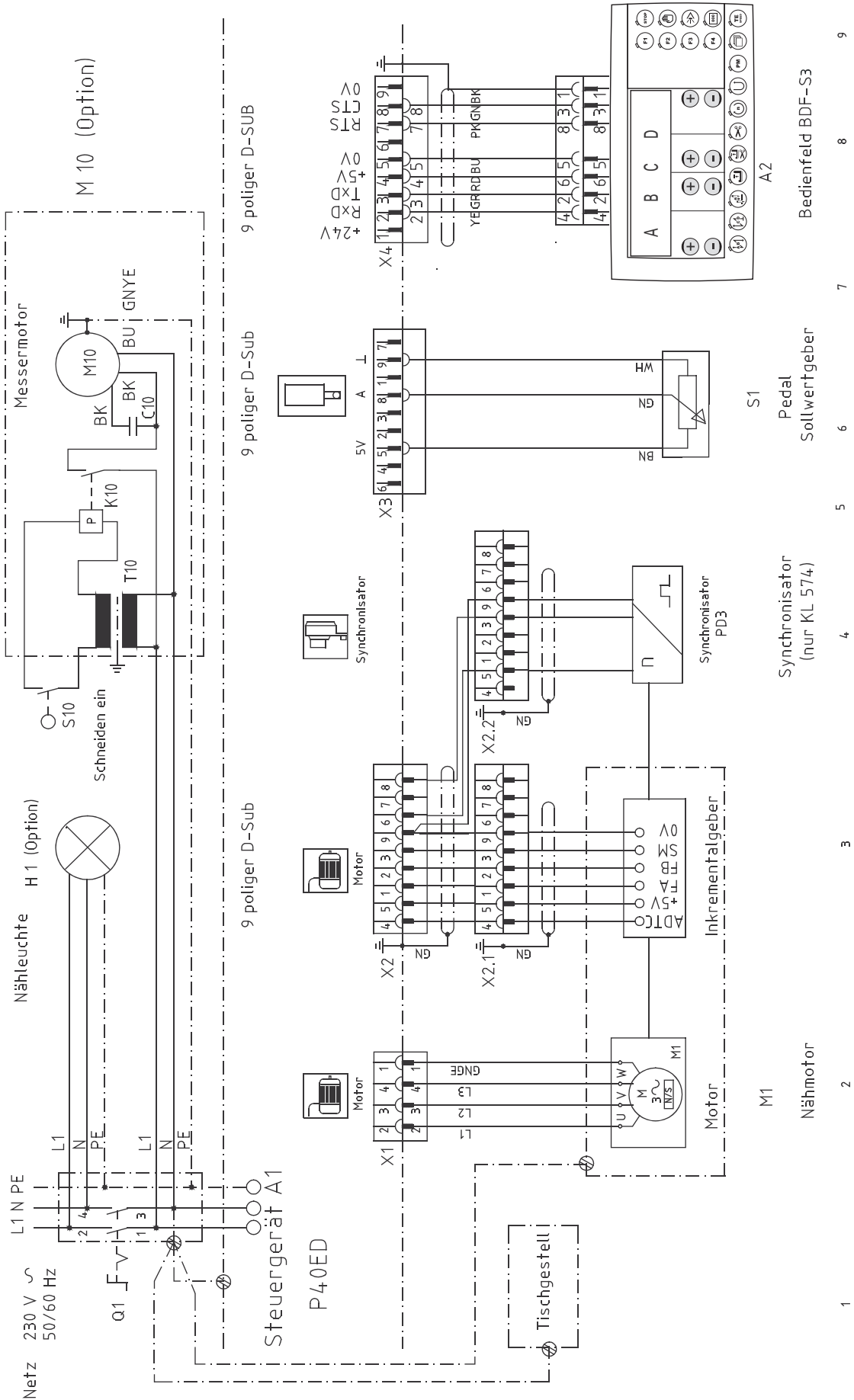
Circuit diagrams

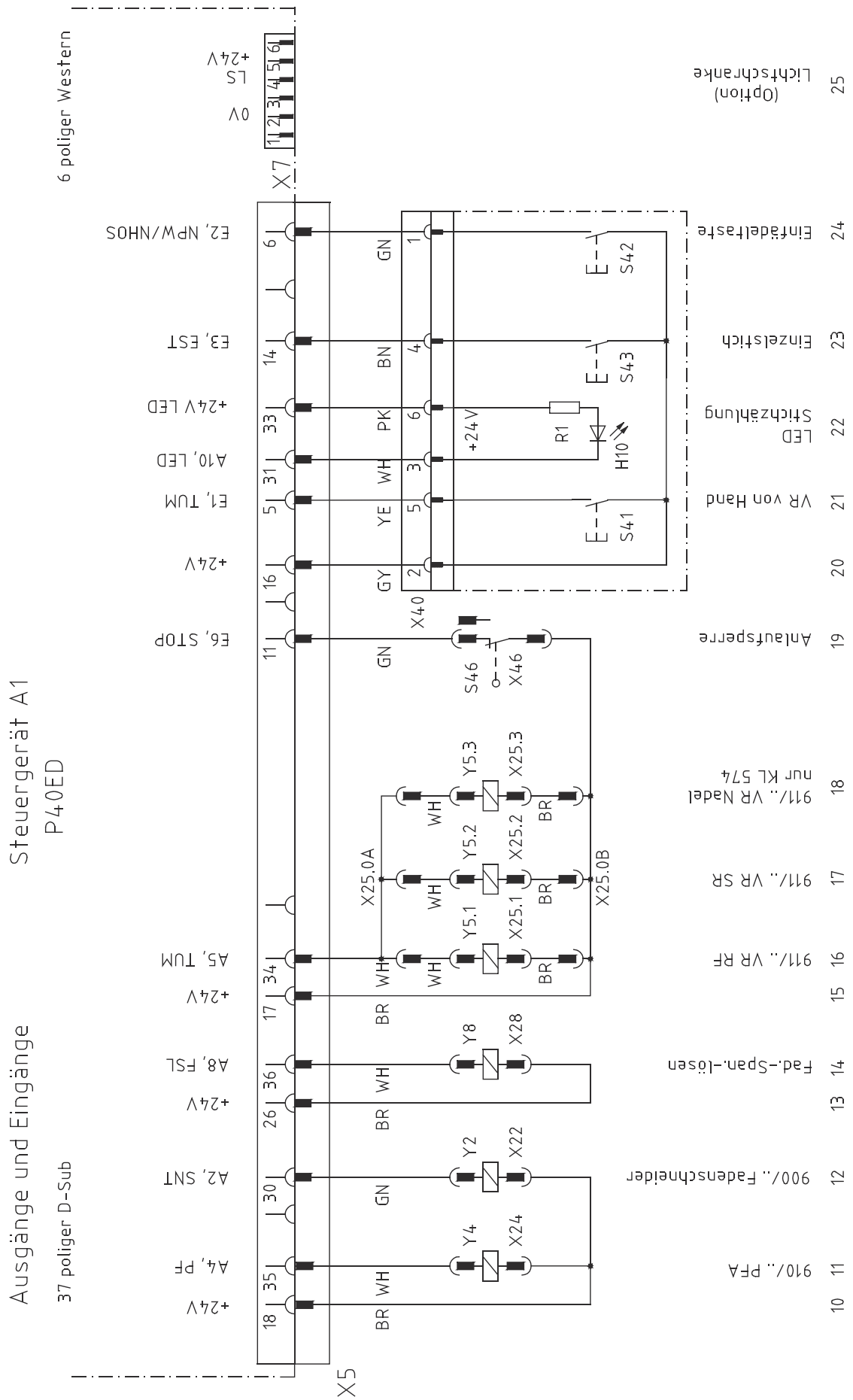
Control packag		
	P40 ED	P44 PD-L
	91-191 524-95	91-191 534-95
X28	Thread tension release plug (FSL)	
X40	Control panel plug	
X46	Start inhibitor plug	
X50	Sewing head recognition plug	-
Y1	-	Automatic presser foot lift (-910/..)
Y2	Thread trimmer (-900/..)	
Y2.1	-	Backtacking device (-911/..) - roller presser
Y2.2	-	Backtacking device(-911/..) - feed wheel
Y2.3	-	Backtacking device (-911/..) - needle on the 574
Y3	-	Thread trimmer (-900/..)
Y4	Automatic presser foot lift (-910/..)	Thread tension release (FSL)
Y5	-	LED speed
Y5.1	Backtacking device (-911/..) - roller presser	-
Y5.2	Backtacking device(-911/..) - feed wheel	-
Y5.3	Backtacking device (-911/..) - needle	-
Y8	Thread tension release (FSL)	-

11.05.02 Block diagram PFAFF 570 / 590 with control unit P40 ED

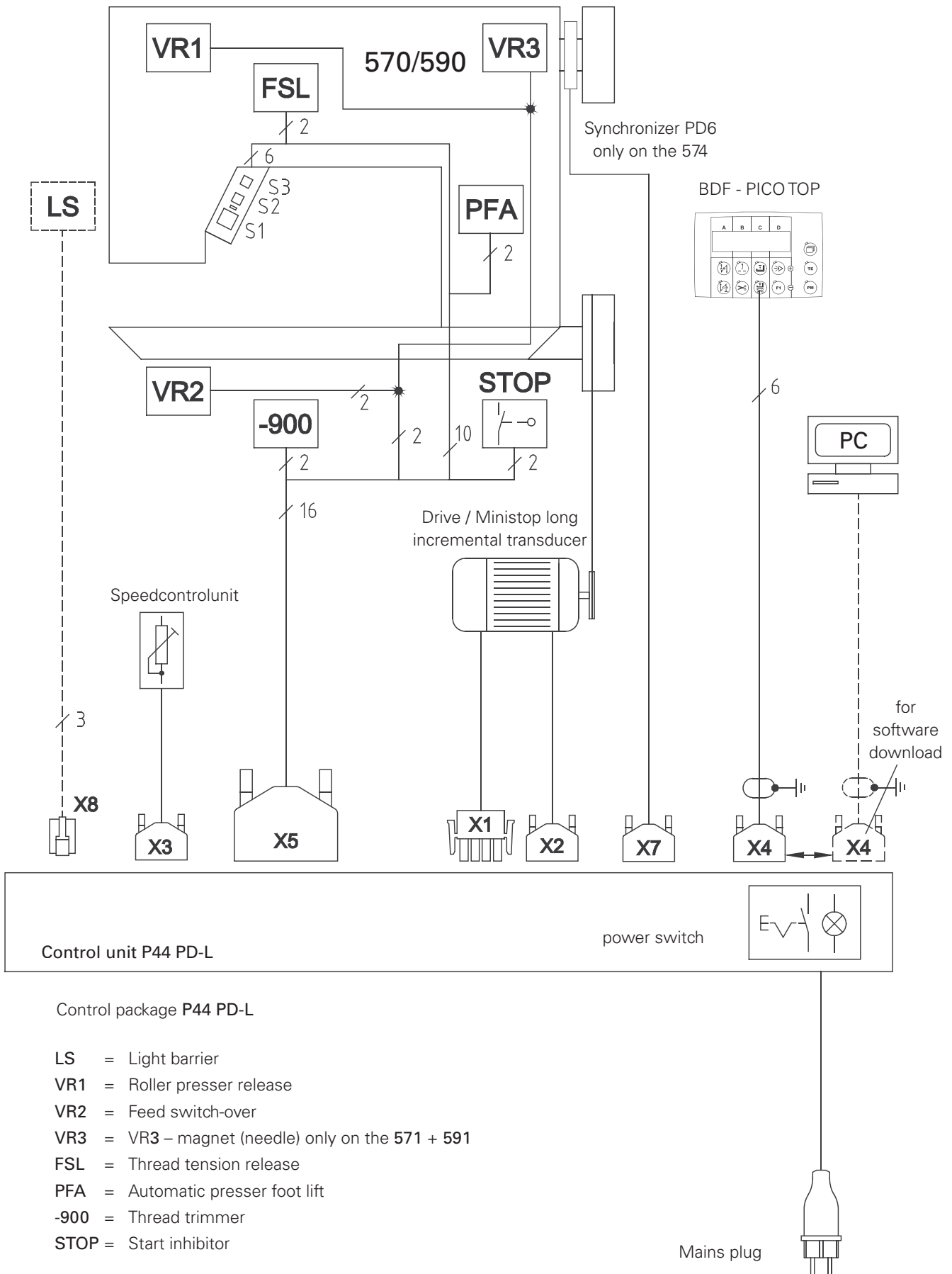


11.05.03 Circuit diagrams 91-191 524-95

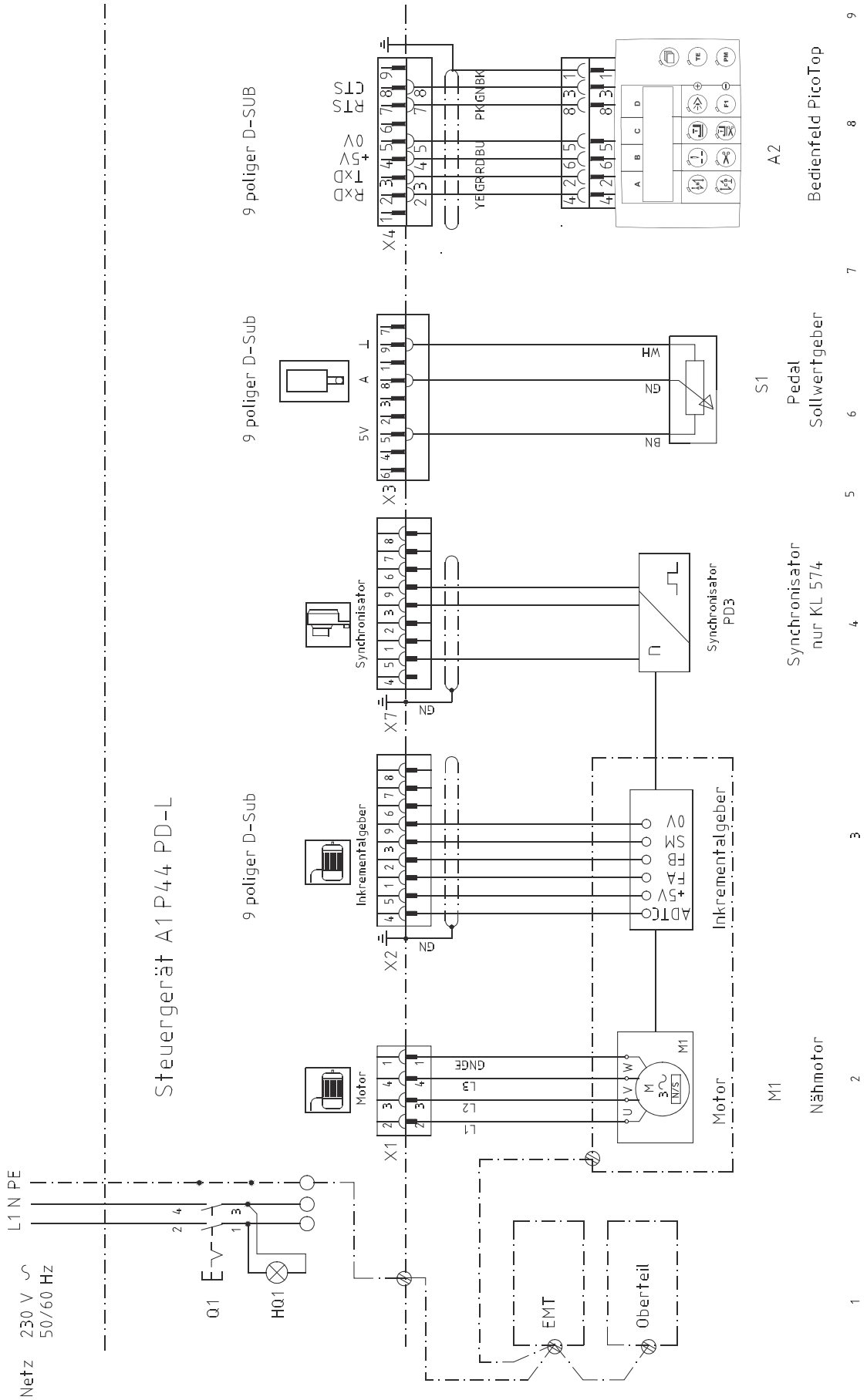


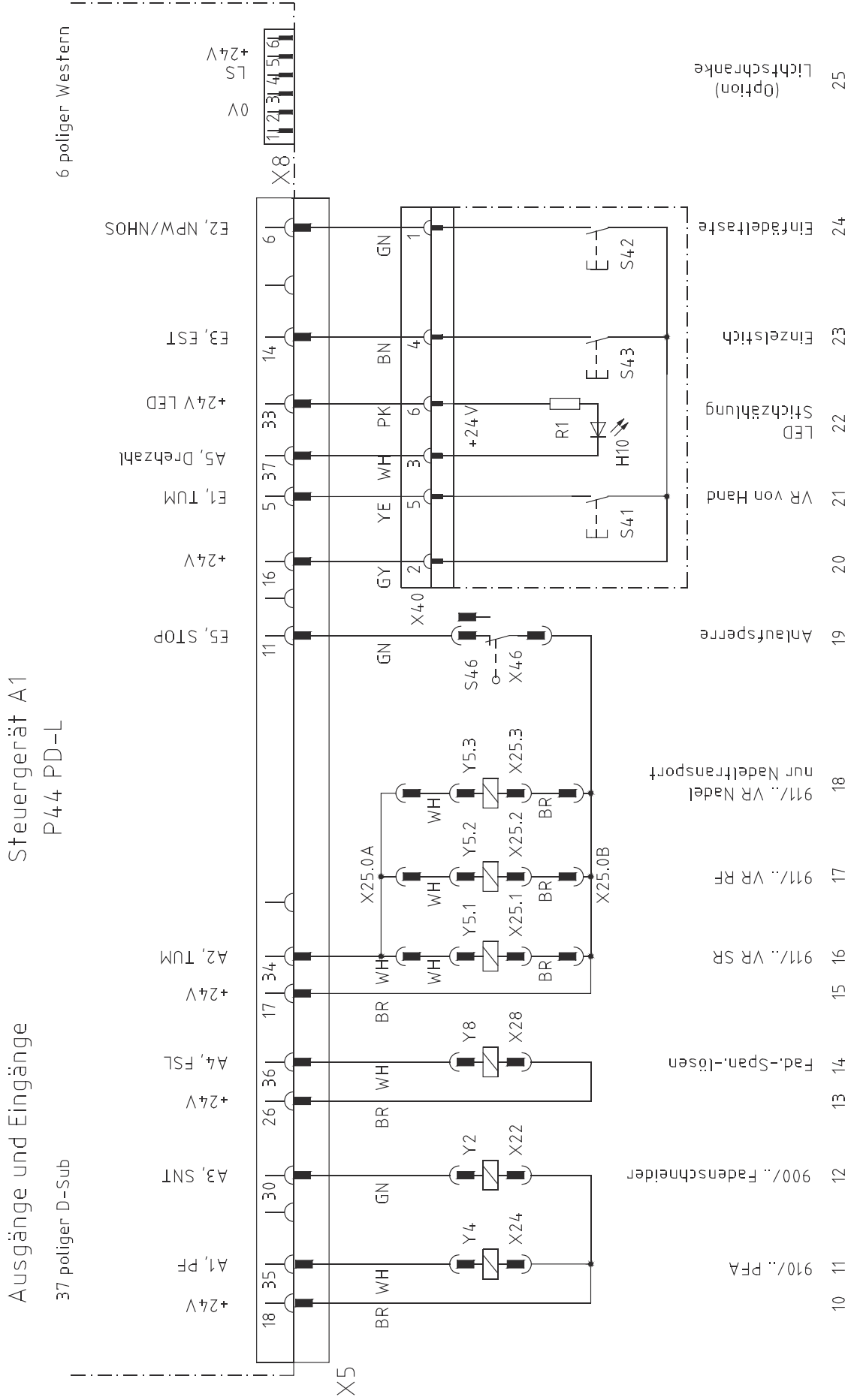


11.05.04 Block diagram PFAFF 570 / 590 with control unit P44 PD-L



11.05.05 Circuit diagrams 91-191 534-95





12 Wearing parts

This is a list of the most important wearing parts.

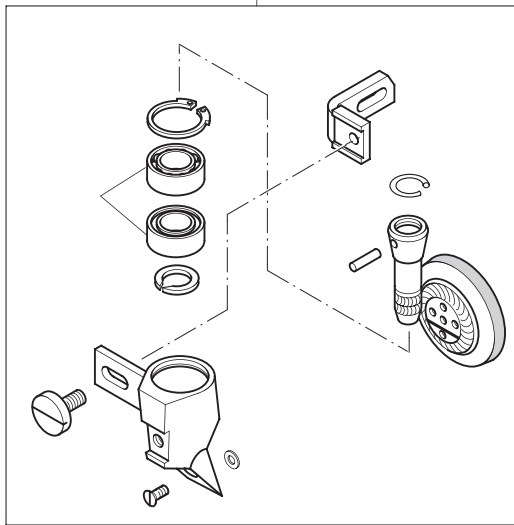
A detailed parts list for the complete machine is included with the accessories.

In case of loss, the parts list can be downloaded from the internet address www.pfaff-industrial.com/pfaff/de/service/downloads As an alternative to

the internet download the parts lists can also be ordered in book form under part no. 296-12-19 232.



- 91-263 934-91 Roller presser 32 mm Ø, 4,0 mm wide coated with plastic-material
- 91-263 433-91 Roller presser 30 mm Ø, 4,0 mm wide, toothed



PFAFF 574

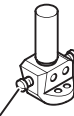
PFAFF 571, 591



91-500 460-05

11-108 093-15

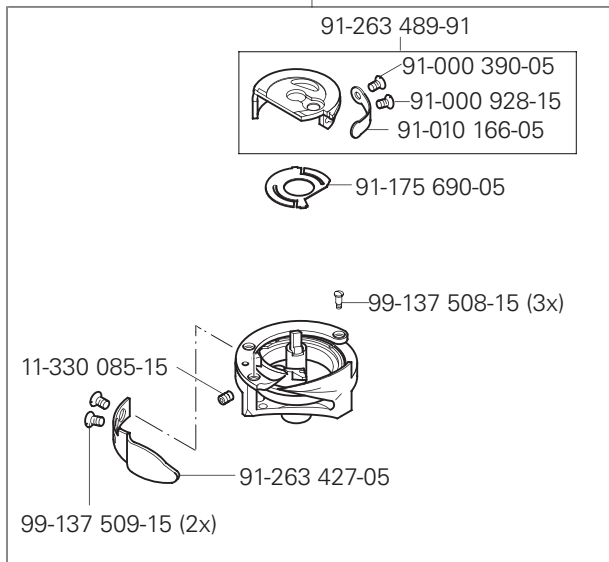
91-173 664-15



91-165 344-15 (2x)

91-263 490-91 B

91-263 495-91 C



91-263 489-91

91-000 390-05

91-000 928-15

91-010 166-05

91-175 690-05

99-137 508-15 (3x)

11-330 085-15

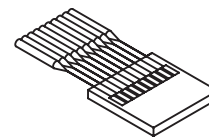
91-263 427-05

99-137 509-15 (2x)

91-118 308-05



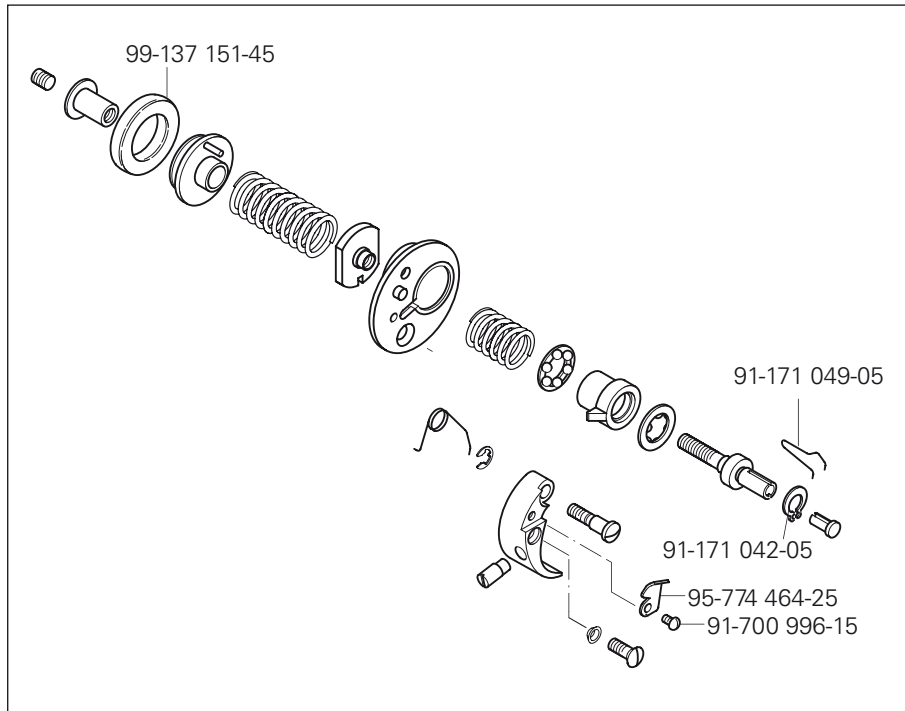
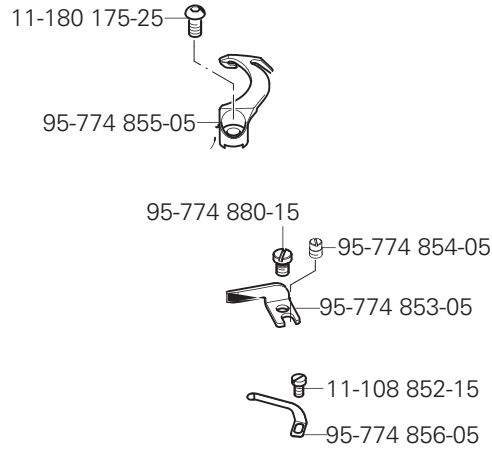
95-774 789-05 (-900/83)



PFAFF 571, 591
System 134

PFAFF 574
System 134-35

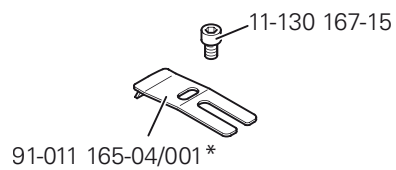
Für Unterklasse -900/83



571-725/..



574-725/..; 591-725/..



* For more knives see parts list



Europäische Union
Wachstum durch Innovation – EFRE



PFAFF Industriesysteme und Maschinen AG

Hans-Geiger-Str. 12 - IG Nord
D-67661 Kaiserslautern

Telefon: +49-6301 3205 - 0
Telefax: +49-6301 3205 - 1386
E-mail: info@pfaff-industrial.com